



Programmable Video Signal Generator

VG-870B/871B/873/874

Instruction Manual

Ver.4.00



Programmable Video Signal Generator

**VG-870B/871B/
873/874**

Instruction Manual

2013.02

Ver.4.00

ASTRODESIGN,Inc

Contents

Introduction	xi
Safety precautions	xi
What is packed with the generator.....	xiv
CONCERNING THE VG-870B/871B/873/874.....	1
1.1 General description	1
1.2 Features	1
1.3 Data configuration	2
1.4 Panel parts and their functions	3
1.4.1 VG-870B/873 front panel.....	3
1.4.2 VG-871B/874 front panel.....	3
1.4.3 RB-1870/RB-1871 panel.....	3
1.4.4 Names of the keys and their functions.....	5
1.4.5 VG-870B/871B/873/874 rear panel.....	7
1.4.6 Names of connectors and their applications	7
1.4.7 VG-870B/871B/873/874 side panel	8
1.4.8 Tools used to operate the VG-870B/871B/873/874	8
1.5 VG-870B/871B/873/874 video units	9
1.5.1 HDMI unit (VM-1817).....	9
1.5.2 TV encoder unit (VM-1812)	9
1.5.3 PC analog unit (VM-1811)	10
1.5.4 DVI unit (VM-1814).....	10
1.5.5 LVDS unit (VM-1815).....	10
1.5.6 Parallel unit (VM-1816).....	11
1.5.7 DisplayPort unit (VM-1820 .. discontinued).....	11
1.5.8 4K2K iTMDS unit (VM-1824)	11
1.5.9 4K2K iTMDS Quad unit (VM-1824-A).....	12
1.5.10 V-by-One HS unit (VM-1825).....	12
1.5.11 SDI unit (VM-1821).....	12
1.5.12 HDMI (3D, ARC) unit (VM-1822).....	13
1.5.13 HDMI 300MHz Unit (VM-1823).....	13
1.5.14 DisplayPort Unit (VM-1820A).....	13
1.5.15 DisplayPort, eDP Unit (VM-1826).....	14
OPERATION PROCEDURES	15
2.1 Flow of basic operations.....	15
2.1.1 Settings required for displays	15
2.1.2 Selecting the timing data	16
2.1.3 Selecting the pattern data.....	17
2.1.4 Selecting the actions.....	19
2.2 Saving the program data	22

2.3	Setting the names	23
2.4	Groups.....	24
2.4.1	Executing groups.....	24
2.4.2	Setting and saving groups	25
2.5	Automatic execution	26
2.6	Displays appearing on the VG-871B / 874 fluorescent display tube.....	28
TIMING DATA SETTINGS		29
3.1	Horizontal timing data editing	29
3.1.1	Horizontal timing data.....	29
3.1.2	Restrictions on the horizontal timing parameters.....	29
3.1.3	Horizontal timing data setting procedure	30
3.2	Vertical timing data editing.....	31
3.2.1	Vertical timing data	31
3.2.2	Restrictions on the vertical timing parameters	31
3.2.3	Vertical timing data setting procedure.....	34
3.2.4	Concerning the scanning modes	35
3.2.5	Concerning the TV modes.....	35
3.2.6	Concerning Serration and EQP	36
3.2.7	Concerning EQP-Fp and EQP-Bp	37
INTERFACE SETTINGS		41
4.1	Output settings	41
4.1.1	Setting the output interfaces to ON or OFF	41
4.1.2	Setting the sync signals to ON or OFF and setting the sync signal polarities.....	42
4.1.3	Setting the level mode	44
4.1.4	Setting the aspect ratio.....	45
4.1.5	Setting the bit length (gray scale) for pattern drawing	47
4.1.6	Selecting RGB or YPbPr and setting the color difference coefficients	49
4.1.7	Setting the analog level	51
4.1.8	Setting the digital level.....	52
4.1.9	Audio sweep settings.....	53
4.1.10	Setting the audio level (temporary settings).....	54
4.1.11	Digital level setting of 3D pattern	55
4.2	HDMI	57
4.2.1	Connectors and pin assignments	57
4.2.2	HDMI setting procedure.....	59
4.2.3	InfoFrame/Package	61
4.2.4	CEC function	83
4.2.5	Embedded audio, high bit rate audio (option).....	86
4.2.6	EDID.....	87
4.2.7	HDCP	87
4.2.8	DDC/CI	87
4.2.9	LipSync.....	87

4.2.10	VD-1673 (HDMI SWITCHER).....	88
4.2.11	Audio Return Channel	89
4.2.12	HDMI Ethernet Channel.....	93
4.3	DVI	105
4.3.1	Connectors and pin assignments.....	105
4.3.2	DVI unit setting procedure	106
4.3.3	PC analog unit (DVI) setting procedure	108
4.3.4	DVI data transfer systems	109
4.3.5	Sync signal polarity setting	112
4.3.6	EDID.....	112
4.3.7	HDCP	112
4.3.8	DDC/CI	112
4.4	4K2K (iTMD5, iTMD5 Quad) (VM-1824, VM-1824-A).....	113
4.4.1	Connectors and pin assignments.....	113
4.4.2	4K2K (iTMD5) unit setting procedure	114
4.4.3	iTMD5 data transfer systems.....	118
4.4.4	Sync signal polarity settings	144
4.5	LVDS	145
4.5.1	Connectors and pin assignments.....	145
4.5.2	LVDS setting procedure.....	146
4.5.3	Data transfer system.....	150
4.5.4	Bit arrays	163
4.6	Parallel	166
4.6.1	Connectors and pin assignments.....	166
4.6.2	Parallel data setting procedure	167
4.7	Analog component signals	170
4.7.1	Connectors and output signals	170
4.7.2	Setting the analog output connectors	170
4.7.3	Setting the analog video level.....	171
4.7.4	Sync signal settings.....	171
4.8	Composite connector and Y/C connector (S connector).....	172
4.8.1	Connectors and output signals	172
4.8.2	Composite signal filter settings	173
4.8.3	Setting the ID signals (Y/C)	174
4.8.4	Functions available with TV standard signals	174
4.9	D5 (D connector)	175
4.9.1	Connectors and pin assignments.....	175
4.9.2	ID signals.....	175
4.10	VGA (D-Sub).....	177
4.10.1	Connectors and pin assignments.....	177
4.10.2	Video level settings.....	177
4.10.3	Sync signal settings.....	177
4.10.4	EDID.....	177
4.10.5	DDC/CI	177

4.11	SCART	178
4.11.1	Connectors and pin assignments	178
4.11.2	SCART setting procedure.....	179
4.11.3	Functions available with TV standard signals	180
4.11.4	Filter settings	180
4.11.5	Concerning the fast blanking signal.....	181
4.11.6	Audio settings	181
4.12	DisplayPort / eDP	182
4.12.1	Connectors and pin assignments	182
4.12.2	DisplayPort setting procedure.....	185
4.12.3	Displaying the DisplayPort setting information.....	194
4.12.4	DisplayPort Analysis	197
4.12.5	Embedded audio	201
4.12.6	EDID	201
4.12.7	HDCP	201
4.12.8	DDC/CI	202
4.12.9	Info Frame	203
4.12.10	Setting for eDP (for VM-1826).....	212
4.13	V-by-One HS (VM-1825)	216
4.13.1	Connectors and pin assignments	216
4.13.2	V-by-One HS setting procedure.....	217
4.13.3	Data transfer systems.....	220
4.13.4	V-by-One HS Control	253
4.14	SDI (VM-1821)	254
4.14.1	Concerning the SDI output	254
4.14.2	SDI setting procedure.....	254
4.14.3	Embedded audio	257
4.15	Analog audio settings	258
4.15.1	Connectors and output signals	258
4.15.2	Analog audio signals	258
4.16	Digital audio.....	260
4.16.1	Digital audio.....	260
4.16.2	Audio sweep settings.....	267
4.16.3	Flash data entry (option).....	267
4.17	Audio sweep setting	267
FUNCTIONS AVAILABLE WITH.....		269
TV STANDARD SIGNALS.....		269
5.1	Macrovision	270
5.1.1	Description and specifications	270
5.1.2	Setting procedure	271
5.2	Closed captions/V-Chip	272
5.2.1	Description and specifications	272

5.2.2	Closed caption settings.....	273
5.2.3	V-Chip settings.....	278
5.2.4	Changing the data superimposing line.....	283
5.3	Teletext	284
5.3.1	Description and specifications	284
5.3.2	Setting procedure	285
5.4	WSS	289
5.4.1	Description and specifications	289
5.4.2	Setting procedure	290
5.5	CGMS -A/ID-1	292
5.5.1	Description and specifications	292
5.5.2	Setting procedure	293
	PATTERN SETTINGS	295
6.1	Color bar patterns.....	295
6.1.1	Types of color bar patterns	295
6.1.2	Color bar pattern customizing.....	296
6.2	Gray scale patterns	299
6.2.1	Types of gray scale patterns.....	299
6.2.2	Gray scale pattern customizing.....	300
6.3	Ramp patterns.....	303
6.3.1	Types of ramp patterns.....	303
6.3.2	Ramp pattern type settings and customizing.....	304
6.4	Sweep patterns.....	307
6.4.1	Types of sweep patterns.....	307
6.4.2	Sweep pattern selection	308
6.5	Monoscope patterns	309
6.5.1	Types of monoscope patterns.....	309
6.5.2	Monoscope pattern selection.....	309
6.6	Raster patterns.....	311
6.6.1	Types of raster patterns	311
6.6.2	Raster pattern type settings and customizing.....	311
6.7	Aspect ratio patterns.....	313
6.7.1	Types of aspect ratio patterns.....	313
6.7.2	Aspect ratio pattern type settings and customizing.....	314
6.8	Checkerboard patterns	317
6.8.1	Types of checkerboard patterns.....	317
6.8.2	Checkerboard pattern customizing	318
6.9	Image/OPT	321
6.9.1	Types of Image/OPT.....	321
6.9.2	Option and image patterns setting.....	322
6.9.3	Moving images settings (option)	323
6.9.4	9-marker (OPT No.76) settings.....	324
6.9.5	3D Image Pattern (OPT No.100) setting.....	326

6.9.6	Setting the 3D pattern (OPT No.101).....	329
6.10	<input type="checkbox"/> × <input type="text" value="ABC"/> patterns	336
6.10.1	Color settings.....	337
6.10.2	Character patterns.....	338
6.10.3	Crosshatch patterns.....	339
6.10.4	Dot patterns	341
6.10.5	Circle patterns	342
6.10.6	Burst patterns	345
6.11	Window patterns.....	347
6.11.1	Types of window patterns	347
6.11.2	Window pattern settings	348
6.12	Cursor patterns.....	351
6.12.1	Cursor settings	351
6.12.2	Cursor operations	354
6.13	Name/List	356
6.13.1	Name/List display	356
6.13.2	Name.....	358
6.13.3	EDID.....	360
6.13.4	DDC/CI	363
6.13.5	HDCP (High-bandwidth Digital Content Protection).....	365
6.13.6	HDMI list.....	367
6.13.7	Timing data list.....	368
6.13.8	Image pattern list.....	369
6.13.9	OPT-USER pattern list.....	369
6.13.10	Subtitle.....	370
6.14	Video black/white reversal.....	372
6.15	Simple animation.....	372
6.15.1	Creating and registering the images.....	372
6.15.2	Simple animation settings.....	375
ACTION SETTINGS.....		377
7.1	Concerning the planes.....	377
7.2	Window actions	378
7.2.1	Scrolling.....	378
7.2.2	Flickering	380
7.2.3	Level up/down actions	381
7.2.4	Level sequence action	382
7.3	Graphic plane scrolling actions.....	384
7.4	Character plane scrolling actions	386
7.5	Subtitle scrolling	388
7.6	0.25- and 0.125-dot scrolling actions (option).....	390
7.7	Motion blur.....	393
7.8	Scroll Sequence	396
7.9	LipSync.....	398

7.10	Black insertion action.....	400
HDCP SETTINGS AND EXECUTION		401
8.1	HDCP settings	401
8.2	HDCP execution	402
8.2.1	Execution procedure.....	402
8.2.2	Screen displays during HDCP execution	404
8.2.3	HDCP/EDID/CEC collective display.....	406
VG-870B/871B/873/874 SYSTEM SETTINGS.....		409
9.1	System settings	409
9.1.1	Beep setting.....	409
9.1.2	Key lock setting.....	410
9.1.3	RS-232C settings.....	411
9.1.4	LAN settings	412
9.1.5	INC/DEC continuity setting	413
9.1.6	INC/DEC interval setting.....	413
9.1.7	Color depth setting.....	414
9.1.8	SAMPLE RGB/YPbPr setting	414
9.1.9	DDC clock setting	415
9.1.10	Trigger mode settings	416
9.1.11	Image - priority settings	422
9.1.12	Image Position Setting.....	423
9.1.13	Cursor coordinate setting.....	424
9.1.14	Mouse speed setting.....	425
9.1.15	Digital Video Level Step setting	426
9.1.16	High-speed drawing mode setting	427
9.1.17	CUSTOM Key1, 2, RB-1871 CUSTOM Key 1, 2	428
9.1.18	Operation mode at power-on	429
9.1.19	CF Prg FolderNo. setting.....	430
9.1.20	AVMUTE operation mode settings.....	431
OTHER FUNCTIONS.....		433
10.1	Copying and erasing data.....	433
10.1.1	Copying programs	433
10.1.2	Copying user characters.....	435
10.1.3	Copying user optional patterns	436
10.1.4	Copying images.....	437
10.1.5	Copying subtitle	438
10.1.6	Copying groups.....	439
10.1.7	Copying auto executions	440
10.1.8	Copying all data	441
10.1.9	Erasing programs	442
10.1.10	Erasing user characters.....	442

10.1.11	Erasing user optional patterns	443
10.1.12	Erasing images.....	443
10.1.13	Erasing subtitle	444
10.1.14	Erasing groups	444
10.1.15	Erasing automatic executions.....	445
10.1.16	Erasing all data.....	445
10.2	Short-cut keys	446
10.3	Information	448
10.4	Data initialization	449
10.4.1	Initializing the system settings	449
10.4.2	Initializing the short-cut data	450
10.5	Formatting	451
10.5.1	Formatting the CF card.....	451
10.5.2	Formatting CF cards for exclusive use of moving images	452
10.5.3	Internal memory formatting and data installation	453
10.6	Adjustments.....	456
10.6.1	Adjusting the RGB video levels of the PC analog unit	456
10.6.2	Adjusting the YPbPr video levels of the TV encoder unit.....	457
10.6.3	Adjusting the COMPOSITE/SCART video levels of the TV encoder unit.....	458
SPECIFICATIONS.....		459
11.1	Main specifications	459
11.1.1	Common specifications.....	459
11.1.2	HDMI unit.....	460
11.1.3	TV encoder unit (VM-1812)	461
	Note: VM-1812-B does not support PAL-N, PAL-60, SECAM. Option Pattern #77 (SMPTE color bar CVBS) is not supported.	461
11.1.4	PC analog unit (VM-1811)	461
11.1.5	DVI unit (VM-1814).....	462
11.1.6	LVDS unit (VM-1815).....	462
11.1.7	PARALLEL unit (VM-1816)	462
11.1.8	DP unit (VM-1820 / 1820A).....	463
11.1.9	DP/eDP Unit (VM-1826)	464
11.1.10	4K2K (iTMDs, iTMDs Quad) unit (VM-1824, VM-1824-A)	466
11.1.11	V-by-One HS unit.....	467
11.1.12	SDI unit (VM-1821).....	468
11.1.13	Moving image module	469
11.1.14	External control.....	469
11.1.15	General specifications	469
11.2	Connector specifications	470
11.2.1	RS232C-Connector	470
11.2.2	Trigger-Connector.....	470
11.3	Internal data	471
11.3.1	Program data.....	471

11.3.2	Optional pattern data	515
11.3.3	User character pattern data	518
11.3.4	Character pattern data	523
11.3.5	Tables of standard signals	531
PRECAUTIONARY ITEMS.....		537
12.1	Differences between the generator models	537
12.2	Relationships between pattern drawing bit length and dot clock frequency.....	537
12.2.1	HDMI Unit (VM-1817, 1822, 1823).....	538
12.2.2	TV encoder unit (VM-1812)	540
12.2.3	PC analog unit (VM-1811)	541
12.2.4	DVI unit (VM-1814).....	542
12.2.5	LVDS unit (VM-1815).....	543
12.2.6	Parallel unit (VM-1816).....	544
12.2.7	DisplayPort unit (VM-1820, 1820A)	545
12.2.8	DP/eDP Unit (VM-1826)	548
12.2.9	4K2K (iTMDs) unit (VM-1824, 1824-A)	550
12.2.10	V-by-One HS unit.....	554
12.3	Concerning the maximum current consumption of the DDC (DP_PWR) power supply	556
LIST OF ERROR MESSAGES.....		557
13.1	Media-related error	557
13.2	General error	557
13.3	HDCP-related error.....	560
13.4	User-generated optional pattern-related error	560

BEFORE OPERATING THE GENERATOR

Introduction

Thank you very much for purchasing this model VG-870B/871B/873/874 video signal generator.

This manual contains details on the operation procedures to be followed when the VG-870B/871B/873/874 is used, the checkpoints and precautions to be observed, and so on. Improper handling may result in malfunctioning so before using the VG-870B/871B, please read through these instructions to ensure that you will operate the generator correctly.

After reading through the manual, keep it in a safe place for future reference.

Safety precautions

WARNING

Concerning the generator

- Do not subject the generator to impact or throw it. Doing so may cause the generator to malfunction, explode or generate abnormally high levels of heat, possibly resulting in a fire.
- Do not use the generator where there is a danger of ignition or explosions.
- Do not place the generator inside a microwave oven or other heating kitchen appliance or inside a high pressure vessel. Doing so may heat up the generator to abnormally high levels, cause smoking, running the risk of the generator's catching fire and/or damaging the circuit components.
- This generator contains some high-voltage parts. If you touch them, you may receive an electric shock and burn yourself so do not attempt to disassemble, repair or remodel the generator.
- If there is a thunderstorm while the generator is being used outdoors, immediately turn off its power, disconnect the power cable from the main unit, and move the generator to a safe place.

Concerning the power cord

- Always take hold of the molded part of the plug when disconnecting the power cord.
- Do not use force to bend the power cord or bunch it up for use. Doing so may cause a fire.
- Do not place heavy objects on top of the power cord. Doing so may damage the cord, causing a fire or electrical shock.

Concerning foreign matter

- Do not spill liquids inside the generator or drop inflammable objects or metal parts into it. Operating the generator under these conditions may cause a fire, electric shocks and/or malfunctioning.

⚠ CAUTION

Concerning the generator

- When connecting the generator to a display unit, use the FG cable provided to connect the frame ground (FG) terminal on the generator to the frame ground terminal on the display unit. If these terminals are not connected together, the generator may fail. Take special care when connecting the generator to a display unit which is under development.

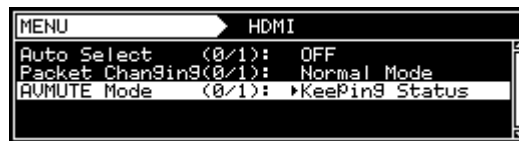

- When disconnecting the VG-870B/871B/873/874 from the display unit, first disconnects the connecting cables, and then disconnects the FG cable.
- When the generator's power is to be turned ON or OFF, be absolutely sure to use the POWER switch on the front panel. Turning the power on and off by plugging in and unplugging the AC power cable may damage the PC card.
- Do not start using the generator straight away: instead, turn on the power of the VG-870B/871B/873/874 and allow it to warm up for about 10 to 15 minutes before use so as to ensure that the VG-870B/871B will operate stably.
- It is forbidden to remove the video units from the generator main unit.
- A Compact Flash (CF) card slot is provided on the front panel. The LED at the side of the slot flashes while the data on the CF card is being accessed. Under no circumstances must the card be ejected while this LED is flashing. Otherwise, malfunctioning may result.
- Never unscrew and open the FC card slot (for the moving image module) cover on the side panel of the main unit while the main unit power is turned on. Malfunctioning may result if the cover or the screw should drop into the chassis of the main unit.

Concerning impact

- This is a precision instrument and, as such, subjecting it to impact may cause malfunctioning. Take special care when moving the generator.
- Do not drop the generator.

Concerning installation

- Install the generator in a stable location. Do not stand it on either of its side panels. Doing so may cause the generator's temperature to rise due to heat generation, possibly resulting in malfunctioning.

When trouble or malfunctioning has occurred

- **In the unlikely event that trouble or malfunctioning should occur, disconnect the generator's power cable, and contact your dealer or an ASTRODESIGN sales representative.**

What is packed with the generator

The generator comes with the following items.

Be absolutely sure to use only the genuine accessories which are supplied with this generator since the use of any non-designated items may cause malfunctioning.

■ Standard accessories

- VG-870B/871B/873/874 main unit
- CD with VG-870B/871B/873/874 instruction manual (what you are now reading): 1 disc
- CompactFlash (CF) card: 1 pc
- CompactFlash (CF) card case: 1 pc
- SP-8870 software installation CD (for Windows): 1 pc
- SP-8870 instruction manual: PDF version (packed with the SP-8870 software installation CD)
- Power cable: 1 pc^{*1}
- FG cable (1.5 meters long): 1 pc^{*1}

*1: These cables are designed to be used exclusively with the VG-870B/871B.

■ Optional accessories

- RB-1870:
Remote control box used exclusively^{*2} with the VG-870B/871B/873/874
- RB-1871:
Simplified remote control box used exclusively^{*2} with the VG-870B/871B/873/874
This remote control box is used exclusively for executing program data, timing data, pattern data and other operations so it cannot be used for setting operations.

*2: These remote control boxes are not compatible with the existing VG series other than VG-870/871/870A/871A.

1

CONCERNING THE VG-870B/871B/873/874

1.1 General description

The VG-870B/871B/873/874 video signal generator supports applications in every field of display test and measuring.

It features a high level of expandability which is achieved by the installing video output interface units.

1.2 Features

■ 16-bit high-speed imaging engine

This generator features a maximum 16-bit x RGB high-gradation imaging engine. It even draws full HD images in an instant.

■ Wide dot clock frequency range

The VG-870B/873 support dot clock frequencies up to 340 MHz. The VG-871B/874 support a maximum dot clock frequency of 250 MHz for analog outputs and a maximum dot clock frequency of 340 MHz for digital outputs.

■ Windows-compatible editing and registration software (SP-8870) provided as standard accessory

This software can be used to edit and register the program data and exercise control over the signals output from the PC connected to the RS-232C/LAN/USB connector.

■ Full variety of sample data incorporated inside

A total of a thousand types of timing data and a thousand types of pattern data are registered inside the VG-870B/871B/873/874 as sample data. They are categorized by standard, application and other factors, and it is possible for the data required to be selected easily.

■ Registration of program data on PC cards

A total of a thousand program data can be registered on a PC card. PC screens or natural images can also be registered. On a PC equipped with a PC card slot, the data can be copied using Explorer provided with Windows 98SE, Windows 2000 or Windows XP.

■ Creation of user option patterns

In addition to the existing basic patterns (including character, crosshatch, color bar and gray scale) and optional patterns, a function that allows users to create their own optional patterns has been added. This function makes it possible to create the optional patterns which are useful for developing and evaluating the next-generation displays.

■ Selection and installation of up to three video units possible

In line with the operating environment, users can select up to three kinds of video units from the six kinds of output units available. In addition, a multiple number of video units of the same kind can be installed, and ASTRODESIGN also provides units which are customized to the needs of the users.

■ Output of uncompressed movies

10-bit uncompressed movies can be output from the output unit which the user has selected.

* **When output units are to be added or replaced, please contact ASTRODESIGN.**

1.3 Data configuration

The data output by the VG-870B/871B/873/874 is managed by the program data. The program data consists of the pattern data which is used to set the data relating to the output images and the timing data which is used to set the data relating to all other output timing data and output conditions.

The table below gives a breakdown of the data.

Block		Description
Timing data	Program Name	Program name
	Timing	Timing
	Output	Output condition
	AUDIO	Audio output
Pattern data	Pattern	Pattern
	Action	Pattern action

A number of types of program data, optional patterns and user character patterns are contained as sample data inside the VG-870B/871B/873/874.

	Number of data
Timing data	1000 (Timing # 1001 to 2000)
Pattern data	1000 (Pattern # 1001 to 2000)
Optional patterns	200 (1 to 200)
User character patterns	16 (F0H to FFH)

The various data can be registered in the **internal memory (approx. 100 MB)** of the VG-870B/871B/873/874 or on CF cards.

	Number of data	
Program data	1000 (Program # 1 to 1000)	
User option patterns	200 (1 to 200)	
Images (image data)	200 (1 to 200) * Number of data depends on the image data size, memory capacity and card capacity.	
User character patterns	16 (E0H to EFH)	
Number of characters in program names	20 characters	
Number of groups	99 (1 to 99)	* For further details on groups, refer to "2.4 Groups."
Number of group data	98 (1 to 98)	
Number of characters in group names	20 characters	



When a CF card has been inserted, the data registered on that card becomes valid, and the data registered in the internal memory becomes invalid.
In the case of image data, both the data on a CF card and the data in the internal memory can be made valid. *

* For further details, refer to "9.1.11 Image - priority settings."

1.4 Panel parts and their functions

1.4.1 VG-870B/873 front panel

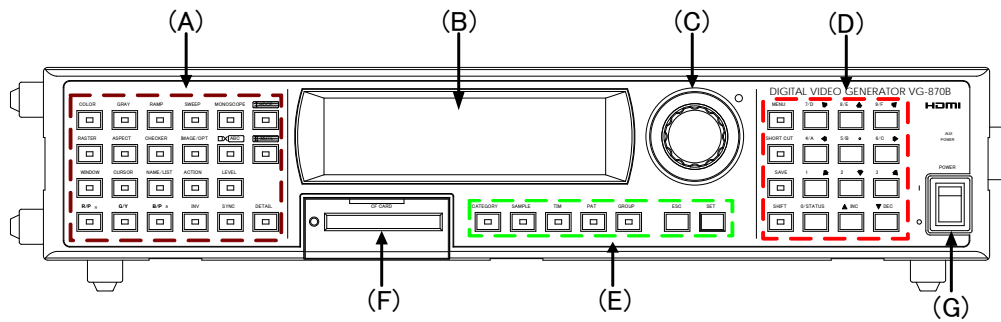

1.4.2 VG-871B/874 front panel

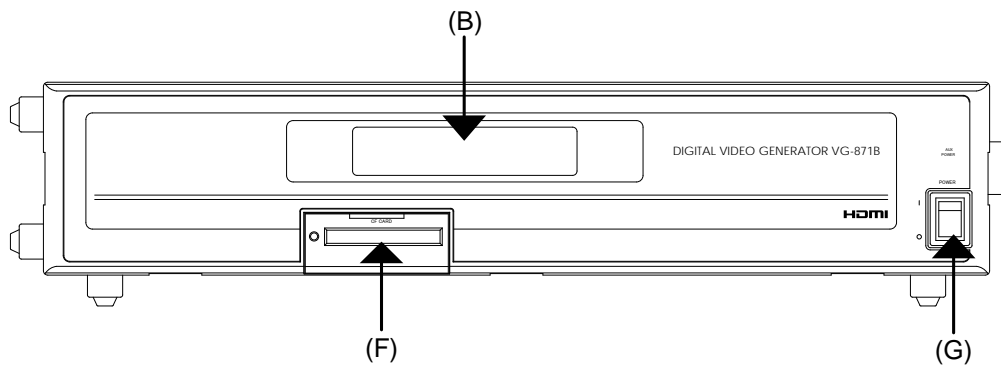

1.4.3 RB-1870/RB-1871 panel

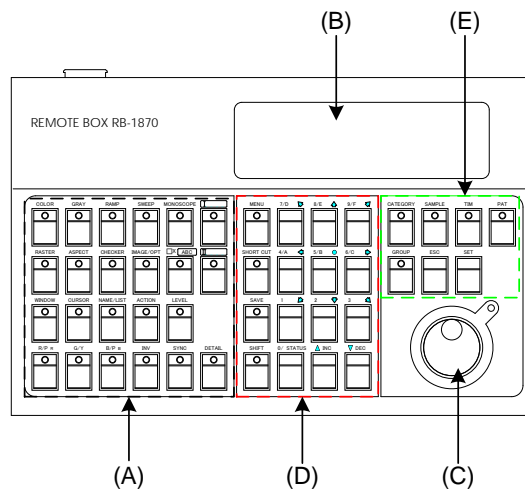

RB-1870

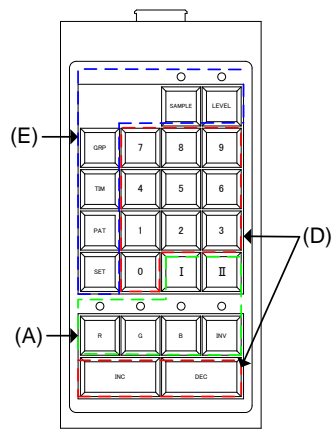











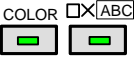







RB-1871







Some restrictions apply to operating the RB-1871. The operable items are described below.

- Selecting and executing programs
- Execution of grouped programs (but group editing is not possible)
- ON/OFF operations of R, G, B and INV keys
- ON/OFF operations of CUSTOM (I, II) keys (default = I: HDCP, II: MUTE)
- Change levels (digital video levels only)

* For further details on the keys, refer to "1.4.4 Names of the keys and their functions."

1.4.4 Names of the keys and their functions

(A)	Pattern keys	 etc.	Used to display and edit the patterns.
	Action key		Used when setting the scroll, flicker and other functions.
	Level key		Used to set the digital video levels, analog video levels and audio levels.
	RGB channel on/off	 etc.	Used to set R, G and B on or off.
	INV key		Used to invert the black and white of the video levels.
	SYNC key		Used to set the sync on or off.
	Detail key		Used to perform the detailed settings of the pattern data, timing data, etc.
	HDCP key (custom key)		Used to set HDCP on or off. (HDCP is a system for protecting content used by HDMI and DVI.)
	MUTE key (custom key)		Used to set the audio on or off (muted). * When setting HDMI AV-MUTE This key functions as the HDMI AV-MUTE On/Off setting. (Refer to "9.1.17 CUSTOM Key1, 2, RB-1871 CUSTOM Key".)
(B)	Menu operation screens		The menu screens are used to set and check the items displayed on the fluorescent display tube.
(C)	Rotary switch		This is turned clockwise or counterclockwise to select the setting items or parameters, change the level settings, etc.
(D)	Number keys	0/STATUS  to 	Used to input numerical values, select the menus, etc.
	INC/DEC	 	Used to select the setting items or parameters, change the level settings, change the program numbers, etc.
	Menu		Used to display the menu screens. When it is pressed while a menu screen is already displayed, the initial screen is restored. * When the menu key indicator is lighted It is no longer possible to use any of the other keys.
	Short-cut key		Used to move to a user-registered menu screen using minimal key operations.
	Save key		Used to save the data which has been set.
	Shift key		Used to input letters of the alphabet with the number keys.

(E)	Category key	CATEGORY 	Used to select the internal sample data by category.
	Sample key	SAMPLE 	Used when the internal sample data is used. * When the sample key indicator is off The data stored on CF cards or stored in the internal memory can be used.
	Timing key	TIM 	Used to display changeable lists when only the output timing data is to be changed.
	Pattern key	PAT 	Used to display changeable lists when only the output pattern data is to be changed.
	Group key	GROUP 	Used to display user-registered groups, etc. and create groups.
	Escape key	ESC 	This key can be used in the following situations <ul style="list-style-type: none"> • When canceling parameter selections or numerical value settings • When returning the displayed menu screen to the previous hierarchical level
	Set key	SET 	Used to enter the setting items and parameters which have been set.
(F)	CF card slot		Used for inserting a CF card or accessing the memory on a CF card.
(G)	Power switch		Used to turn the power of the VG-870B/VG-871B/873/874 on and off.

1.4.5 VG-870B/871B/873/874 rear panel

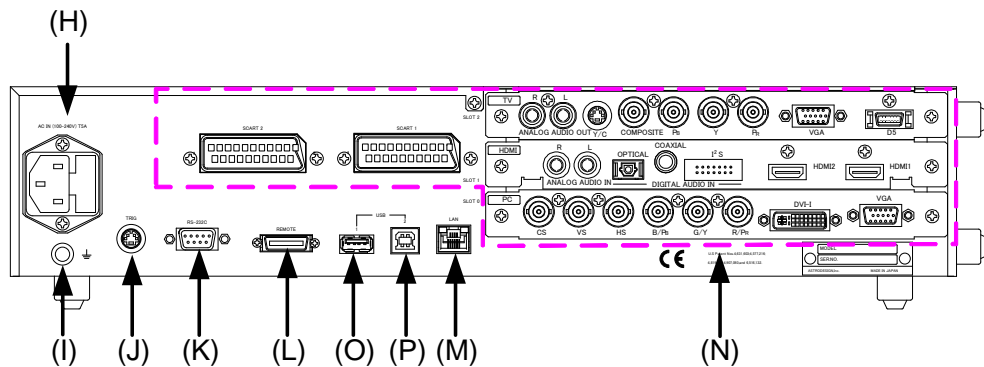

1.4.6 Names of connectors and their applications

(H)	AC power socket		Connect the power cable here. Any voltage from 100 V to 240 V is supported.
(I)	Frame ground		Connect this frame ground terminal to the frame ground terminal of the unit which is connected to the VG-870B/871B/873/874.
(J)	TRIG connector		This is the trigger input/output connector.
(K)	RS-232C connector		This is used to connect a personal computer using an RS-232C cable.
(L)	Remote connector		This is used to connect the dedicated remote control box (RB-1870 or RB-1871) to operate the generator by remote control.
(M)	LAN port		This port is used for connection to a LAN using the Ethernet cable.
(N)	Units		These connectors enable up to three interface units (VM18XX series) to be installed.
(O)	USB (1)		This connector supports a regular USB mouse. * When the cursor is displayed Using the USB mouse, the pointer on the monitor can be moved.
(P)	USB (2)		This connector is used to connect the generator with a PC to enable the VG-870B/871B/873/874 to be operated using the SP-8870 software, etc. Refer to the instruction manual of the SP-8870 software for further details.

1.4.7 VG-870B/871B/873/874 side panel

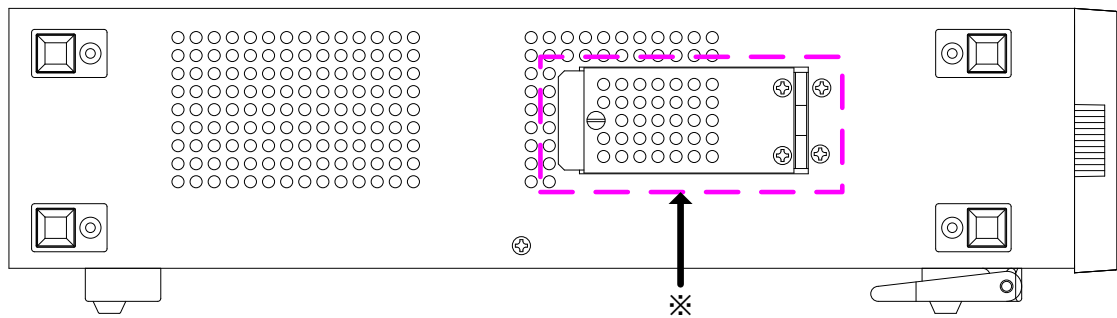

* Note

Open or close this cover when inserting or removing a CF card for the moving image module.
Do not open the cover while the power is on.

1.4.8 Tools used to operate the VG-870B/871B/873/874

The table below lists the operation tools of this generator and the restrictions on the operation of each of these tools.

Operation tool	Restriction on operation	Remarks
VG-870B/873 front panel	These enable all the generator functions to be operated.	The controls can be used only by the VG-870B/873 main unit.
RB-1870	These enable all the generator functions to be operated.	This remote control box makes it possible to perform the same operations as the ones which are performed on the front panel of the VG-870B/873.
RB-1871	Programs can be read only.	This is a simplified remote control box which is intended for use on production lines.
SP-8870	These enable all the generator functions to be operated.	This software program is intended for performing operations and editing using a PC.

1.5 VG-870B/871B/873/874 video units

The VG-870B/871B/873/874 is constructed to allow video interface units to be installed. Video interface signals are output from these units. Up to three units can be installed.

* When one or more video units are to be replaced, please contact ASTRODESIGN.

1.5.1 HDMI unit (VM-1817)

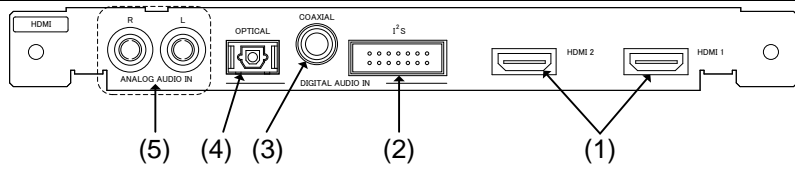

(1)	HDMI output connectors	The same images are output simultaneously to two systems. (HDMI connectors)
(2)	I2S digital audio input connector	The I2S digital audio signals can be supplied here. The audio signals which have been input to this connector can be output as the embedded audio in the HDMI output. (Option)
(3)	COAX digital audio input connector	The signals supplied here can be output to the monitor as the HDMI embedded audio.
(4)	TOSLINK digital audio input connector	Digital audio signals can be input using an optical connection. The signals input here can be output to the monitor as the HDMI embedded audio.
(5)	Analog audio input connectors	Analog audio signals (L/R) can be supplied here. (RCA connectors) The signals supplied here can be output to the monitor as the HDMI embedded audio.

1.5.2 TV encoder unit (VM-1812)

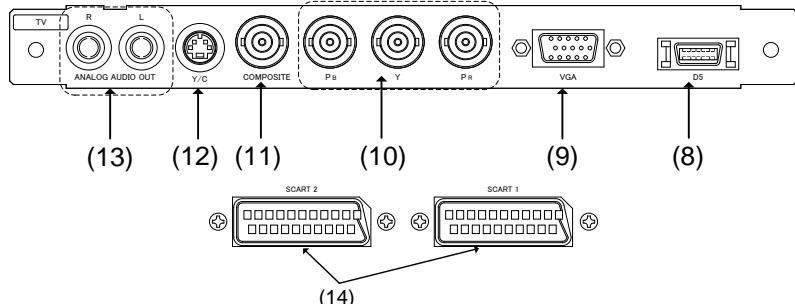

(8)	D5 output connector	Analog component signals can be output here. (D5 connector)
(9)	VGA output connector	The analog component signals (RGB) and H/V separate sync signals can be output here. (Shrink Dsub 15-pin connector)
(10)	Analog component output connectors	YPbPr analog component signals can be output here. (BNC connectors)
(11)	Composite output connector	NTSC, PAL or SECAM composite (VBS) signals can be output here. (BNC connector)
(12)	Y/C output connector	The Y/C signals can be output here (S connector)
(13)	Analog audio output connectors	Analog audio signals (L/R) can be output here. (RCA connectors)
(14)	SCART output connector	NTSC, PAL or SECAM composite (VBS) signals, Y/C signals and analog component signals (RGBHV) signals can be output here.

1.5.3 PC analog unit (VM-1811)

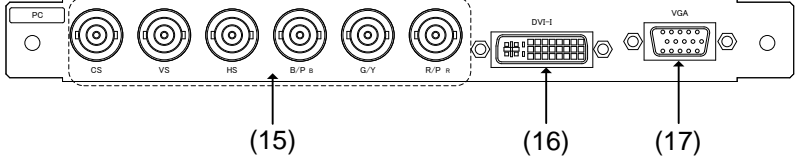

For details on connectors (7) and (9), refer to the descriptions of the DVI unit and TV encoder unit, respectively.

(15)	Analog component output connectors	Either RGB signals or color difference signals (YPbPr/YCpCr) can be selected and output here. H/V separate sync and CS (composite sync) can be output.
(16)	DVI-I output connector	Digital or analog signals can be output from this connector. (DVI-I connector) HDCP is supported. (Dual-Link is not supported.)
(17)	VGA output connector	Analog component signals (RGBHV) can be output as separate H/V sync signals here. (Shrink Dsub 15-pin connector)

1.5.4 DVI unit (VM-1814)

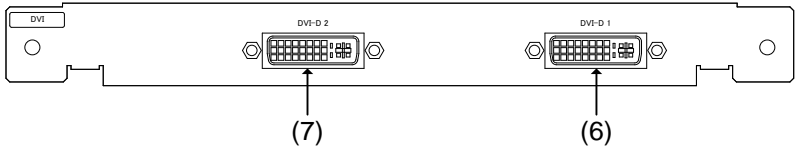

(6)	DVI-D output connector	Only digital signals can be output here. (DVI-D connector) Dual-Link is supported. (HDCP is not supported.)
(7)	DVI-D output connector	Only Digital signals can be output here. (DVI-D connector) HDCP is supported. (Dual-Link is not supported.)

1.5.5 LVDS unit (VM-1815)

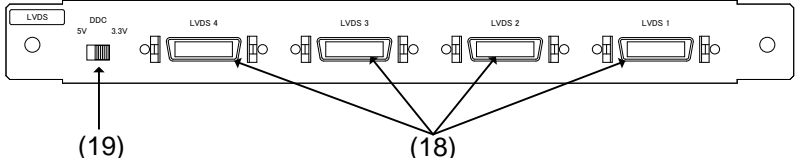

(18)	LVDS output connectors	The signals of four 10-bit systems can be output here. DISM or OpenLDI can be selected.
(19)	(DDC power supply selector switch)	This switch is not normally used. It can select the supply voltage when DDC is used.

1.5.6 Parallel unit (VM-1816)

(20)	Parallel output connectors	The signals of two 8-bit systems can be output here.
(21)	Supply voltage setting	This enables the supply voltage (1.8 V, 2.5 V, 3.3 V or 5 V) to be selected.
(22)	Signal level setting	This enables the signal level (1.8 V, 2.5 V, 3.3 V or 5 V) to be selected.

1.5.7 DisplayPort unit (VM-1820 .. discontinued)

(23)	DisplayPort output	Two systems of split drawing signals can be simultaneously output here.
(24)	TOSLINK digital audio input	This connector enables digital audio data to be input using an optical connection. Digital audio data can be output to the monitor as the embedded audio data of the DisplayPort output.

1.5.8 4K2K iTMDS unit (VM-1824)

(25)	iTMDS(DVI) output connectors	Only Digital signals can be output here. (iTMDS connector) Dual-Link is supported. (HDCP is not supported.)
------	------------------------------	---

1.5.9 4K2K iTMDS Quad unit (VM-1824-A)

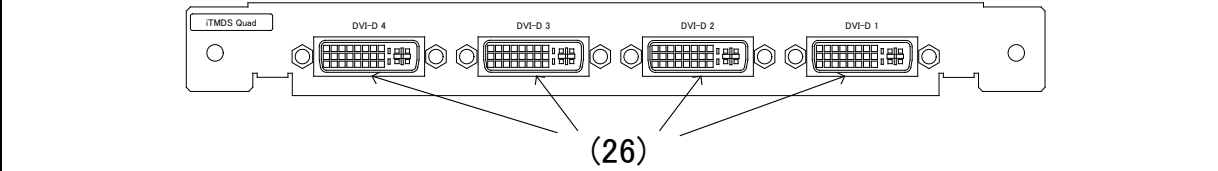
		
(25)	iTMDS (DVI) output connectors	Only Digital signals can be output here. (iTMDS connector) Single link is supported.

1.5.10 V-by-One HS unit (VM-1825)

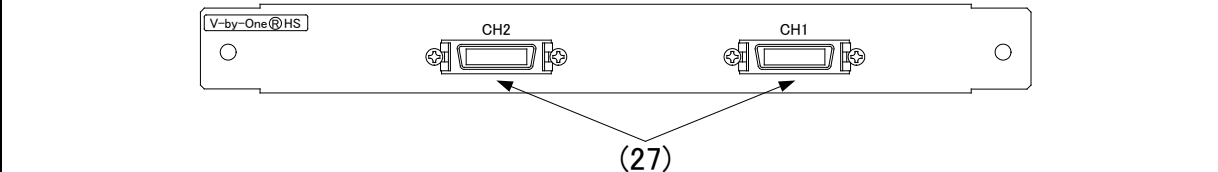
		
(27)	V-by-One HS output connectors	These connectors support up to 4 lanes with one channel (and 8 lanes by two channels).

1.5.11 SDI unit (VM-1821)

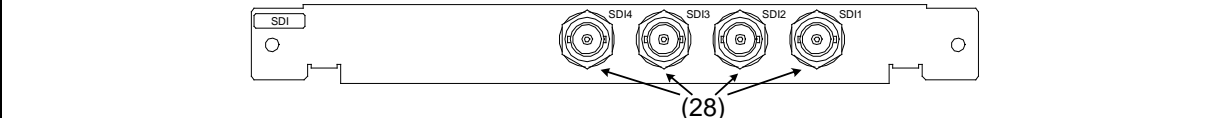
		
(28)	SDI output connectors	These connectors support four SD, HD or 3G signals or two Dual Link signals.

1.5.12 HDMI (3D, ARC) unit (VM-1822)

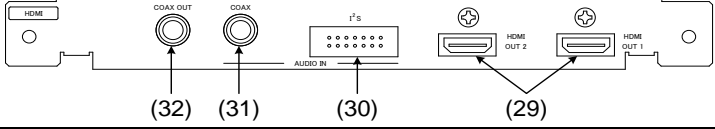
		
(29)	HDMI output connectors	The same images and sound can be output simultaneously from these two connectors. (HDMI connectors)
(30)	I2S digital audio input connector	The I2S digital audio signals can be supplied here. The audio signals which have been input to this connector can be output as the embedded audio in the HDMI output. (Option)
(31)	COAX digital audio input connector	The signals supplied here can be output to the monitor as the HDMI embedded audio.
(32)	COAX digital audio output connector (ARC only)	The sound input <u>by the ARC function</u> of HDMI is output from this connector as it is.

1.5.13 HDMI 300MHz Unit (VM-1823)

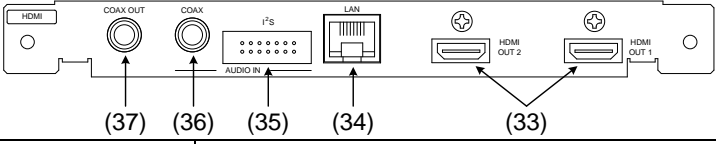
		
(33)	HDMI Output	The same images and sound can be output simultaneously from these two connectors. (HDMI connectors)
(34)	LAN	When using HEC function, the Ethernet that is input from VG is thoroughly output.
(35)	I2S digital audio input connector	The I2S digital audio signals can be supplied here. The audio signals which have been input to this connector can be output as the embedded audio in the HDMI output. (Option)
(36)	COAX digital audio input connector	The signals supplied here can be output to the monitor as the HDMI embedded audio.
(37)	COAX digital audio output connector (ARC only)	The sound input by the ARC function of HDMI is output from this connector as it is.

1.5.14 DisplayPort Unit (VM-1820A)

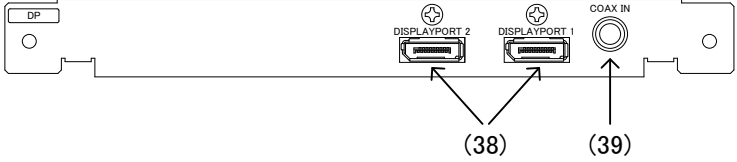
		
(38)	DisplayPort Output	Outputs 2 channels simultaneously and split-drawing is available.
(39)	COAX digital audio input	This connector enables digital audio data to be input using a coaxial connection. Digital audio data can be output to the monitor as the embedded audio data of the DisplayPort output.

1.5.15 DisplayPort, eDP Unit (VM-1826)

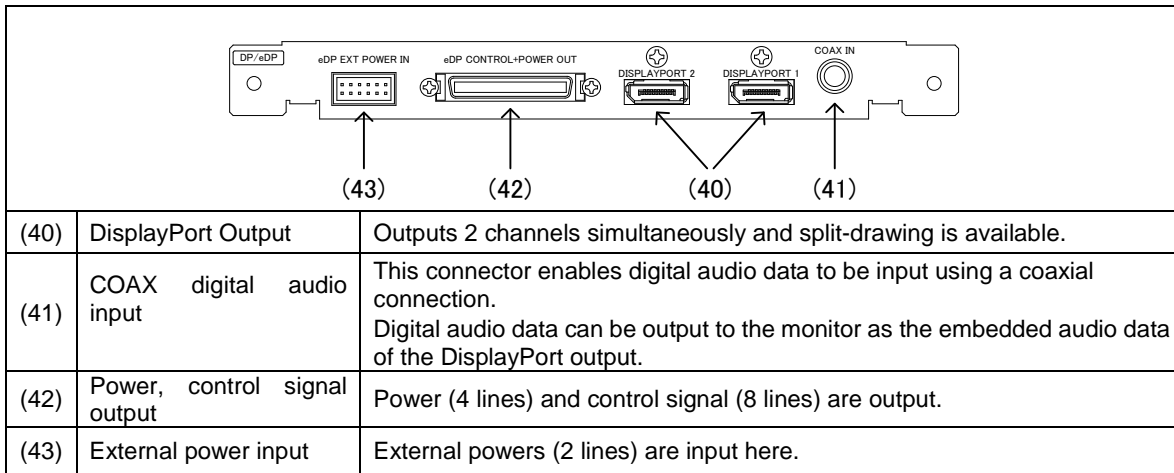

Do not attempt to remove the interface units from the main unit due to the risk of damage.
When units are to be added or replaced, please contact ASTRODESIGN.

2

OPERATION PROCEDURES

2.1 Flow of basic operations

2.1.1 Settings required for displays

The **timing data** and **pattern data** must be set in order for the test patterns to be displayed from the generator. The following items are set for these data.

In the case of this generator, the **timing data** and **pattern data** are collectively referred to as the "program data."

Program data

Timing data

Video timing data settings

- Horizontal timing
- Vertical timing

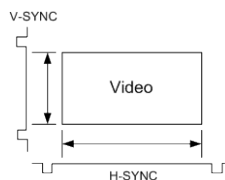

Output settings

- On or off for each interface
- Settings inherent to interfaces



Audio output settings

- Sound source, level
- Frequency
- On or off of channels

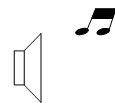

Pattern data

Pattern data settings

- Type, size, level and other settings



Action settings

- Scroll
- Flicker
- Level sweep







2.1.2 Selecting the timing data

There are two ways to select the timing data.





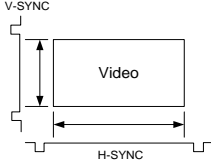



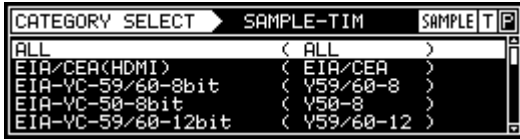

- 1) Input the timing data numbers directly.
- 2) Select the timing data from the categories.

1) Input the timing data numbers directly.

<p>(1) Input the timing data number (1001 to 1999) using    \Rightarrow number keys ( to ).</p>	<p>Video timing data output</p>  <p>The display patterns are not changed.</p>
---	---

2) Select the timing data from the categories.

The timing data of the internal sample data is classified by category such as EIA or VESA (PC). Select the desired timing data from the category which contains it.

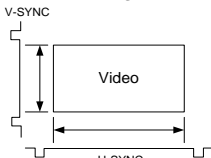



<p>(1)  \Rightarrow  \Rightarrow </p>	
<p>(2) Select the category using  or  Δ INC, and then press  SET.</p>	
<p>(3) Select the timing data using  or  Δ INC, and then press  SET.</p>	<p>Video timing data output</p>  <p>The display patterns are not changed.</p>

2.1.3 Selecting the pattern data





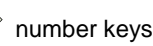

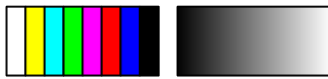







There are four ways to select the pattern data.

- 1) Input the pattern data numbers directly.
- 2) Select the pattern data from the categories.
- 3) Select the pattern data using the pattern keys.
- 4) Select the patterns for each program data.

















1) Inputting the pattern data numbers directly

<p>(1) Input the pattern data number (1001 to 1999) using    ( to ).</p>	<p>The corresponding pattern is displayed.</p>  etc.
---	--





















2) Selecting the pattern data from the categories

<p>(1)   </p>	<p>The pattern category is displayed.</p> 
<p>(2) Select the category using  or  , and then press .</p>	<p></p>
<p>(3) Select the pattern using  or  , and then press .</p>	<p>The pattern is displayed.</p>  etc.

3) Selecting the pattern data using the pattern keys

<p>(1) Select the key corresponding to the pattern, such as  or , to be displayed.</p>	<p>The pattern of the selected type is displayed.</p>  <p>Lighted:  selected; off:  deselected.</p>
<p>(2) When setting details for the pattern or changing the pattern type. Press .</p>	<p>The pattern selection screen is displayed.</p> 
<p>(3) Select the pattern using  or  , and then press .</p> <p>Select the pattern directly using the number keys ( to ).</p> <p>Press  to select .</p>	<p>The selected pattern is displayed.</p> 

4) Selecting the patterns for each program data













<p>(1) Select Program Edit using  →  or  , and then press .</p>	 <pre> MENU Program Edit Program Name : ▶EIA1920x1080P@60 Timing < TIM > Output < TIM > Audio < TIM > Pattern < PAT > </pre>																																																
<p>(2) Select Pattern (PAT) using  or  , and then press .</p>	 <pre> MENU Pattern Pattern/RGB/INU Select >>> Color Bar >>> Gray Scale >>> Ramp >>> Sweep >>> </pre>																																																
<p>(3) Select Pattern/RGB/INV Select using  or  , and then press .</p>	 <pre> MENU Pattern/RGB/INU Select <input checked="" type="checkbox"/> Color Bar <input type="checkbox"/> Gray Scale <input type="checkbox"/> Ramp <input type="checkbox"/> Sweep <input type="checkbox"/> Monoscope </pre>																																																
<p>(4) Select the item using  or  , and then press .</p> <p>→ Selected or deselected is displayed.</p>	<p>The selected pattern is indicated by a check mark <input checked="" type="checkbox"/>.</p> <table border="1"> <tbody> <tr> <td>Color Bar</td> <td>Check this to select the color bar pattern.</td> </tr> <tr> <td>Gray Scale</td> <td>Check this to select the gray scale pattern.</td> </tr> <tr> <td>Ramp</td> <td>Check this to select the ramp pattern.</td> </tr> <tr> <td>Sweep</td> <td>Check this to select the sweep (sine wave) pattern.</td> </tr> <tr> <td>Monoscope</td> <td>Check this to select the monoscope pattern.</td> </tr> <tr> <td>Raster</td> <td>Check this to select the raster pattern.</td> </tr> <tr> <td>Aspect</td> <td>Check this to select the pattern for checking the aspect ratio.</td> </tr> <tr> <td>Checker</td> <td>Check this to select the checkerboard pattern.</td> </tr> <tr> <td>Image/OPT</td> <td>Check this to select the bitmap image, an optional pattern, or a moving image.</td> </tr> <tr> <td>Character</td> <td>Check this to select the character pattern.</td> </tr> <tr> <td>Cross Hatch</td> <td>Check this to select the crosshatch pattern.</td> </tr> <tr> <td>Dot</td> <td>Check this to select the dot pattern.</td> </tr> <tr> <td><input type="checkbox"/></td> <td>Check this to select the frame pattern.</td> </tr> <tr> <td><input checked="" type="checkbox"/></td> <td>Check this to select the cross pattern.</td> </tr> <tr> <td><input checked="" type="checkbox"/></td> <td>Check this to select the center marker pattern.</td> </tr> <tr> <td>Circle</td> <td>Check this to select the circle pattern.</td> </tr> <tr> <td>Burst</td> <td>Check this to select burst (continuous black and white).</td> </tr> <tr> <td>Window</td> <td>Check this to select the window pattern.</td> </tr> <tr> <td>Cursor</td> <td>Check this to select the cursor pattern.</td> </tr> <tr> <td>Name/List</td> <td>Check this to select the name/list function.</td> </tr> <tr> <td>R/Pr</td> <td>Check this to set the pattern R (red) or Pr output on or off. Normally, this is kept checked.</td> </tr> <tr> <td>G/Y</td> <td>Check this to set the pattern G (green) or Y (luminance) output on or off. Normally, this is kept checked.</td> </tr> <tr> <td>B/Pb</td> <td>Check this to set the pattern B (blue) or Pb output on or off. Normally, this is kept checked.</td> </tr> <tr> <td>INV</td> <td>Check this invert the black and white of the video level.</td> </tr> </tbody> </table>	Color Bar	Check this to select the color bar pattern.	Gray Scale	Check this to select the gray scale pattern.	Ramp	Check this to select the ramp pattern.	Sweep	Check this to select the sweep (sine wave) pattern.	Monoscope	Check this to select the monoscope pattern.	Raster	Check this to select the raster pattern.	Aspect	Check this to select the pattern for checking the aspect ratio.	Checker	Check this to select the checkerboard pattern.	Image/OPT	Check this to select the bitmap image, an optional pattern, or a moving image.	Character	Check this to select the character pattern.	Cross Hatch	Check this to select the crosshatch pattern.	Dot	Check this to select the dot pattern.	<input type="checkbox"/>	Check this to select the frame pattern.	<input checked="" type="checkbox"/>	Check this to select the cross pattern.	<input checked="" type="checkbox"/>	Check this to select the center marker pattern.	Circle	Check this to select the circle pattern.	Burst	Check this to select burst (continuous black and white).	Window	Check this to select the window pattern.	Cursor	Check this to select the cursor pattern.	Name/List	Check this to select the name/list function.	R/Pr	Check this to set the pattern R (red) or Pr output on or off. Normally, this is kept checked.	G/Y	Check this to set the pattern G (green) or Y (luminance) output on or off. Normally, this is kept checked.	B/Pb	Check this to set the pattern B (blue) or Pb output on or off. Normally, this is kept checked.	INV	Check this invert the black and white of the video level.
Color Bar	Check this to select the color bar pattern.																																																
Gray Scale	Check this to select the gray scale pattern.																																																
Ramp	Check this to select the ramp pattern.																																																
Sweep	Check this to select the sweep (sine wave) pattern.																																																
Monoscope	Check this to select the monoscope pattern.																																																
Raster	Check this to select the raster pattern.																																																
Aspect	Check this to select the pattern for checking the aspect ratio.																																																
Checker	Check this to select the checkerboard pattern.																																																
Image/OPT	Check this to select the bitmap image, an optional pattern, or a moving image.																																																
Character	Check this to select the character pattern.																																																
Cross Hatch	Check this to select the crosshatch pattern.																																																
Dot	Check this to select the dot pattern.																																																
<input type="checkbox"/>	Check this to select the frame pattern.																																																
<input checked="" type="checkbox"/>	Check this to select the cross pattern.																																																
<input checked="" type="checkbox"/>	Check this to select the center marker pattern.																																																
Circle	Check this to select the circle pattern.																																																
Burst	Check this to select burst (continuous black and white).																																																
Window	Check this to select the window pattern.																																																
Cursor	Check this to select the cursor pattern.																																																
Name/List	Check this to select the name/list function.																																																
R/Pr	Check this to set the pattern R (red) or Pr output on or off. Normally, this is kept checked.																																																
G/Y	Check this to set the pattern G (green) or Y (luminance) output on or off. Normally, this is kept checked.																																																
B/Pb	Check this to set the pattern B (blue) or Pb output on or off. Normally, this is kept checked.																																																
INV	Check this invert the black and white of the video level.																																																













































2.1.4 Selecting the actions

There are two ways to select actions.















- 1) Select the action using the action key.
- 2) Select and set the action for each program data.

1) Selecting the action using the action key

(1)	Press the  key.	The action selection screen is displayed. 																		
(2)	Select the action using  or   , and then press  .	The selected action is indicated by a check mark  .  <p>To select the window action, the window pattern must be displayed first.</p> <table border="1"> <tbody> <tr> <td>GC-SCROL</td> <td>Check this to scroll the pattern.</td> </tr> <tr> <td>G-SCROLL</td> <td>Check this to scroll the pattern.</td> </tr> <tr> <td>C-SCROLL</td> <td>Check this to scroll the pattern.</td> </tr> <tr> <td>W-SCROLL</td> <td>Check this to scroll the window.</td> </tr> <tr> <td>W-FLICKR</td> <td>Check this to flicker the window.</td> </tr> <tr> <td>W-LEVEL</td> <td>Check this to change the window level.</td> </tr> <tr> <td>W-L.SEQ</td> <td>Check this to execute the window level sequence.</td> </tr> <tr> <td>M-BLUR</td> <td>Check this to execute motion blur.</td> </tr> <tr> <td>S-SCROLL</td> <td>Check this to scroll the subtitle pattern.</td> </tr> </tbody> </table>	GC-SCROL	Check this to scroll the pattern.	G-SCROLL	Check this to scroll the pattern.	C-SCROLL	Check this to scroll the pattern.	W-SCROLL	Check this to scroll the window.	W-FLICKR	Check this to flicker the window.	W-LEVEL	Check this to change the window level.	W-L.SEQ	Check this to execute the window level sequence.	M-BLUR	Check this to execute motion blur.	S-SCROLL	Check this to scroll the subtitle pattern.
GC-SCROL	Check this to scroll the pattern.																			
G-SCROLL	Check this to scroll the pattern.																			
C-SCROLL	Check this to scroll the pattern.																			
W-SCROLL	Check this to scroll the window.																			
W-FLICKR	Check this to flicker the window.																			
W-LEVEL	Check this to change the window level.																			
W-L.SEQ	Check this to execute the window level sequence.																			
M-BLUR	Check this to execute motion blur.																			
S-SCROLL	Check this to scroll the subtitle pattern.																			
(3)	Select the action using  or   , and then press  .	 <p>On this screen, the scroll direction and number of steps are set when the GC-SCROL, G-SCROLL or C-SCROLL action has been checked.</p> <table border="1"> <tbody> <tr> <td>←, →, ↑, ↓</td> <td>Select these to scroll in the directions of the arrows.</td> </tr> <tr> <td> </td> <td>Select this to stop the scrolling temporarily.</td> </tr> <tr> <td>RESET</td> <td>Select this to return the pattern to its original position. (It is displayed only while scrolling is stopped temporarily.)</td> </tr> <tr> <td>STEP+1</td> <td>Select this to increment the scroll step by 1.</td> </tr> <tr> <td>STEP-1</td> <td>Select this to decrement the scroll step by 1.</td> </tr> <tr> <td>EDIT</td> <td>Select this to perform the detailed scroll settings.</td> </tr> </tbody> </table>	←, →, ↑, ↓	Select these to scroll in the directions of the arrows.		Select this to stop the scrolling temporarily.	RESET	Select this to return the pattern to its original position. (It is displayed only while scrolling is stopped temporarily.)	STEP+1	Select this to increment the scroll step by 1.	STEP-1	Select this to decrement the scroll step by 1.	EDIT	Select this to perform the detailed scroll settings.						
←, →, ↑, ↓	Select these to scroll in the directions of the arrows.																			
	Select this to stop the scrolling temporarily.																			
RESET	Select this to return the pattern to its original position. (It is displayed only while scrolling is stopped temporarily.)																			
STEP+1	Select this to increment the scroll step by 1.																			
STEP-1	Select this to decrement the scroll step by 1.																			
EDIT	Select this to perform the detailed scroll settings.																			

(4)	<p>Select the action using  or  ,</p> <p>and then press .</p>	 <p>On this screen, the scroll direction and number of steps are set when the W-SCROLL action has been checked.</p> <table border="1"> <tbody> <tr> <td>, , , </td> <td>Select these to scroll in the directions of the arrows.</td> </tr> <tr> <td></td> <td>Select this to stop the scrolling temporarily.</td> </tr> <tr> <td>RESET</td> <td>Select this to return the pattern to its original position. (It is displayed only while scrolling is stopped temporarily.)</td> </tr> <tr> <td>STEP+1</td> <td>Select this to increment the scroll step by 1.</td> </tr> <tr> <td>STEP-1</td> <td>Select this to decrement the scroll step by 1.</td> </tr> <tr> <td>EDIT</td> <td>Select this to perform the detailed scroll settings.</td> </tr> </tbody> </table>	 ,  ,  , 	Select these to scroll in the directions of the arrows.		Select this to stop the scrolling temporarily.	RESET	Select this to return the pattern to its original position. (It is displayed only while scrolling is stopped temporarily.)	STEP+1	Select this to increment the scroll step by 1.	STEP-1	Select this to decrement the scroll step by 1.	EDIT	Select this to perform the detailed scroll settings.
 ,  ,  , 	Select these to scroll in the directions of the arrows.													
	Select this to stop the scrolling temporarily.													
RESET	Select this to return the pattern to its original position. (It is displayed only while scrolling is stopped temporarily.)													
STEP+1	Select this to increment the scroll step by 1.													
STEP-1	Select this to decrement the scroll step by 1.													
EDIT	Select this to perform the detailed scroll settings.													
(5)	<p>Select the action using  or  ,</p> <p>and then press .</p>	 <p>On this screen, the level increment/decrement and direction as well as the number of steps are set when the W-LEVEL action has been checked.</p> <table border="1"> <tbody> <tr> <td>UP</td> <td>Select this to increment the level.</td> </tr> <tr> <td>DOWN</td> <td>Select this to decrement the level.</td> </tr> <tr> <td>STOP</td> <td>Select this to temporarily stop the level change.</td> </tr> <tr> <td>STEP+1</td> <td>Select this to increment the level change step by 1.</td> </tr> <tr> <td>STEP-1</td> <td>Select this to decrement the level change step by 1.</td> </tr> <tr> <td>EDIT</td> <td>Select this to perform the detailed level settings.</td> </tr> </tbody> </table>	UP	Select this to increment the level.	DOWN	Select this to decrement the level.	STOP	Select this to temporarily stop the level change.	STEP+1	Select this to increment the level change step by 1.	STEP-1	Select this to decrement the level change step by 1.	EDIT	Select this to perform the detailed level settings.
UP	Select this to increment the level.													
DOWN	Select this to decrement the level.													
STOP	Select this to temporarily stop the level change.													
STEP+1	Select this to increment the level change step by 1.													
STEP-1	Select this to decrement the level change step by 1.													
EDIT	Select this to perform the detailed level settings.													
(6)	<p>Select the action using  or  ,</p> <p>and then press .</p>	 <p>On this screen, the scroll direction and number of steps are set when the S-SCROLL action has been checked.</p> <table border="1"> <tbody> <tr> <td>, , , </td> <td>Select these to scroll in the directions of the arrows.</td> </tr> <tr> <td></td> <td>Select this to stop the scrolling temporarily.</td> </tr> <tr> <td>RESET</td> <td>Select this to return the pattern to its original position. (It is displayed only while scrolling is stopped temporarily.)</td> </tr> <tr> <td>STEP+1</td> <td>Select this to increment the scroll step by 1.</td> </tr> <tr> <td>STEP-1</td> <td>Select this to decrement the scroll step by 1.</td> </tr> <tr> <td>EDIT</td> <td>Select this to perform the detailed scroll settings.</td> </tr> </tbody> </table>	 ,  ,  , 	Select these to scroll in the directions of the arrows.		Select this to stop the scrolling temporarily.	RESET	Select this to return the pattern to its original position. (It is displayed only while scrolling is stopped temporarily.)	STEP+1	Select this to increment the scroll step by 1.	STEP-1	Select this to decrement the scroll step by 1.	EDIT	Select this to perform the detailed scroll settings.
 ,  ,  , 	Select these to scroll in the directions of the arrows.													
	Select this to stop the scrolling temporarily.													
RESET	Select this to return the pattern to its original position. (It is displayed only while scrolling is stopped temporarily.)													
STEP+1	Select this to increment the scroll step by 1.													
STEP-1	Select this to decrement the scroll step by 1.													
EDIT	Select this to perform the detailed scroll settings.													







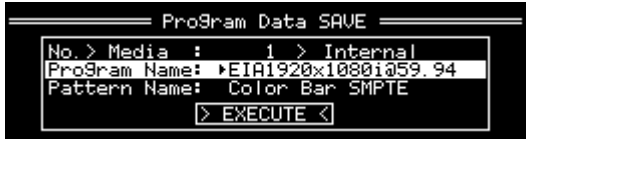

2) Select and set the action for each program data.

(1)	<p>Select Program Edit using  → </p> <p>or  INC  DEC, and then press .</p>	
(2)	<p>Select Action (PAT) using  or </p> <p> DEC, and then press .</p>	
(3)	<p>Select the item using  or  INC  DEC,</p> <p>and then press .</p>	<p>One of the following actions is selected, and the detailed settings are performed.</p> <p>For details on the setting procedure, refer to “ACTION SETTINGS.”</p> <ul style="list-style-type: none"> • Graphic Plane • Character Plane • Window • Subtitle • Motion Blur • 0.25 / 0.125 dot Scroll • Lip Sync • Black Insertion

2.2 Saving the program data

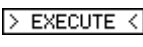
Upon completion of program editing, save the data.

If the power is turned off without saving the data, the status before the changes were made will be restored.

(1)										
(2)	<p>Select the item using  or  , and then press .</p>	<table border="1"> <tr> <td data-bbox="745 526 906 584">No.</td> <td data-bbox="912 526 1374 584">The program number is set here. (0001 to 1000)</td> </tr> <tr> <td data-bbox="745 593 906 645">Media</td> <td data-bbox="912 593 1374 645">The internal memory or CF card is selected here.</td> </tr> <tr> <td data-bbox="745 654 906 705">Program Name</td> <td data-bbox="912 654 1374 705">Any name (containing up to 20 characters) can be allocated as the program name.</td> </tr> <tr> <td data-bbox="745 714 906 763">Pattern Name</td> <td data-bbox="912 714 1374 763">Any name (containing up to 20 characters) can be allocated as the pattern name.</td> </tr> </table>	No.	The program number is set here. (0001 to 1000)	Media	The internal memory or CF card is selected here.	Program Name	Any name (containing up to 20 characters) can be allocated as the program name.	Pattern Name	Any name (containing up to 20 characters) can be allocated as the pattern name.
No.	The program number is set here. (0001 to 1000)									
Media	The internal memory or CF card is selected here.									
Program Name	Any name (containing up to 20 characters) can be allocated as the program name.									
Pattern Name	Any name (containing up to 20 characters) can be allocated as the pattern name.									
(3)	<p>Select  using  or  , and then press .</p>	<p>The program data is saved.</p>								















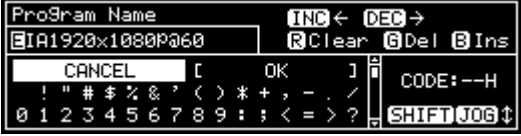

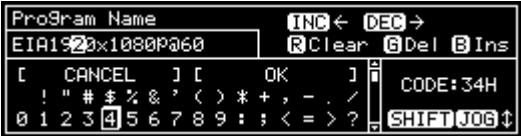

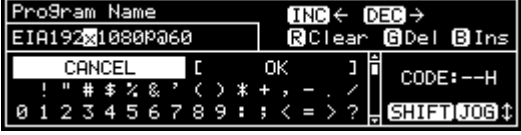

If a CF card has been inserted, the data registered on the card will be enabled and the data registered in the internal memory will be disabled.
For the image data, it is possible to enable both the data registered on the CF card and the data in the internal memory.
 *

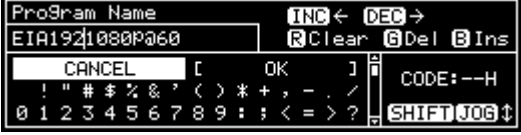
* For further details, refer to “9.1.11 Image - priority settings.”

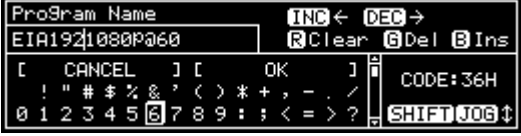
2.3 Setting the names

When timing or pattern data is edited and the edited data is to be saved, the name used for the program can be changed.

<p>(1) </p> <p>Select Name using  or  , and then press .</p>	
<p>(2) <u>To decide on the positions where the character changes are to be made:</u></p> <p> (when moving to the left)</p> <p> (when moving to the right)</p>	<p>The position where the character of the name is to be input changes.</p> 
<p><u>To delete all the characters:</u></p> <p></p>	<p>All the characters already input for the name are cleared.</p> 
<p><u>To delete one character:</u></p> <p></p>	<p>The character at the cursor position is deleted.</p> 
<p><u>To change character insert/overwrite:</u></p> <p> Use this to switch between inserting and overwriting the characters.</p>	<p>Insert is switched to overwrite or vice versa.</p> 
<p><u>To input characters:</u></p> <p>Select the characters using , and enter them using .</p>	<p>The characters are input.</p> 
<p>(3) <u>To enter the program name:</u></p> <p>Select OK using   .</p>	<p>The name is changed.</p>

2.4 Groups

Registering programs as “group” is useful when specific programs are to be combined and used repeatedly.

Examples include times on a TV set inspection process when specific timing and pattern data are combined for repeated use.



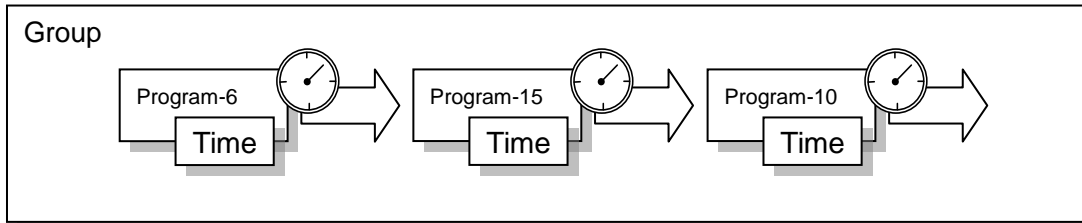









It is possible to set not only the timing and pattern data execution sequence but the execution time of each program as well.



Up to 98 programs can be registered in a group. **Up to 99 groups** can be registered.

























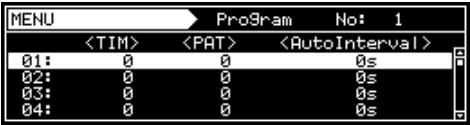
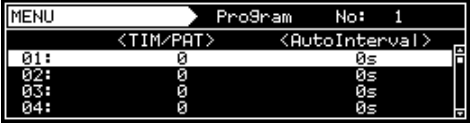

2.4.1 Executing groups

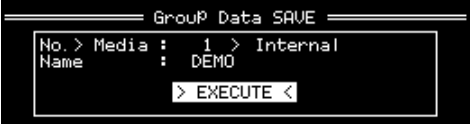
The combinations of programs and patterns which are used with a high frequency and which have been registered by the user can be executed.

(1)	GROUP 	
(2)	Select the groups using  or   , and then press  .	 <p>Only the programs registered as groups can be selected.</p>
(3)	Select the groups using  or   , and then press  .	<p>The programs in the group are executed.</p> <p>When  or  is used, the programs are executed in ascending or descending order without pressing .</p>

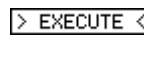



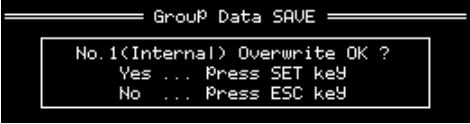



















2.4.2 Setting and saving groups













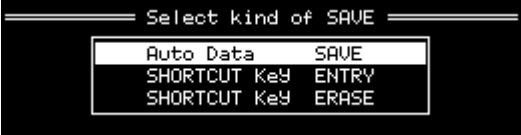

The combinations of programs and patterns which are used with a high frequency can be saved.

<p>(1)</p> 									
<p>(2)</p> <p>Select Group Edit using  or , and then press .</p>									
<p>(3)</p> <p>Select the items using  or  , and then press .</p>	<table border="1"> <tbody> <tr> <td>No.</td> <td>The number of the desired group is set here. (01 to 99)</td> </tr> <tr> <td>Name</td> <td>Any name (consisting of up to 20 characters) can be allocated as the group name.</td> </tr> <tr> <td>Edit Mode</td> <td>TIM/PAT: The timing data and pattern data are set separately. Program: The number of the program is designated here.</td> </tr> <tr> <td>Program</td> <td>Depending on the Edit Mode setting, the display screen in (4) below will differ.</td> </tr> </tbody> </table>	No.	The number of the desired group is set here. (01 to 99)	Name	Any name (consisting of up to 20 characters) can be allocated as the group name.	Edit Mode	TIM/PAT : The timing data and pattern data are set separately. Program : The number of the program is designated here.	Program	Depending on the Edit Mode setting, the display screen in (4) below will differ.
No.	The number of the desired group is set here. (01 to 99)								
Name	Any name (consisting of up to 20 characters) can be allocated as the group name.								
Edit Mode	TIM/PAT : The timing data and pattern data are set separately. Program : The number of the program is designated here.								
Program	Depending on the Edit Mode setting, the display screen in (4) below will differ.								
<p>(4)</p> <p>Select the numbers (01 to 98) of the TIM or PAT programs and AutoInterval using  ,  or  , and then press .</p> <p>The programs set in the group are executed in sequence from 01 up to 98.</p> <ul style="list-style-type: none"> • If 0 is set for both TIM and PAT • If 0 is set for Program <p>In both of the above cases, 0 is recognized as the end of the group.</p>	<p>When TIM/PAT is selected as the Edit Mode setting</p>  <p>When Program is selected as the Edit Mode setting</p>  <table border="1"> <tbody> <tr> <td>TIM/PAT</td> <td>The program numbers are set in this column.</td> </tr> <tr> <td>TIM</td> <td>The timing data numbers are listed here.</td> </tr> <tr> <td>PAT</td> <td>The pattern data numbers are listed here.</td> </tr> <tr> <td>Auto Interval</td> <td>The execution times during Auto Display are set here (0 to 999 seconds).</td> </tr> </tbody> </table>	TIM/PAT	The program numbers are set in this column.	TIM	The timing data numbers are listed here.	PAT	The pattern data numbers are listed here.	Auto Interval	The execution times during Auto Display are set here (0 to 999 seconds).
TIM/PAT	The program numbers are set in this column.								
TIM	The timing data numbers are listed here.								
PAT	The pattern data numbers are listed here.								
Auto Interval	The execution times during Auto Display are set here (0 to 999 seconds).								
<p>(5)</p> <p>This completes the setting operations. The group data is now saved.</p> 									
<p>(6)</p> <p>Select the items using  or  , and then press .</p>	<table border="1"> <tbody> <tr> <td>No.</td> <td>The number of the group is set here. (01 to 99)</td> </tr> <tr> <td>Media</td> <td>Internal: The group data is saved in the internal memory. CF Card: The group data is saved on an external CF card.</td> </tr> <tr> <td>Name</td> <td>Any name (consisting of up to 20 characters) can be allocated.</td> </tr> </tbody> </table>	No.	The number of the group is set here. (01 to 99)	Media	Internal: The group data is saved in the internal memory. CF Card: The group data is saved on an external CF card.	Name	Any name (consisting of up to 20 characters) can be allocated.		
No.	The number of the group is set here. (01 to 99)								
Media	Internal: The group data is saved in the internal memory. CF Card: The group data is saved on an external CF card.								
Name	Any name (consisting of up to 20 characters) can be allocated.								
<p>(7)</p> <p>Select  using  or , and then press .</p> <p>If previous data exists, a display appears prompting the user to confirm whether it is acceptable for the existing data to be overwritten.</p>	 <p>This completes the saving of the group data.</p>								

2.5 Automatic execution

The data in the selected groups and program numbers can be automatically output in accordance with the delay time which has been set.

(1)		
(2)	Select Auto Edit using  or   , and then press  .	
(3)	Selecting the Mode setting Select Program or Group using  or   , 0/STATUS  1  .	
(4)	Select Setting using  or   , and then press  .	<p><When Program has been selected as the Mode setting></p>  <p>Interval: The time during which each pattern is to be displayed is set here from 0 to 999 seconds.</p> <p>Program (Start-Stop): The start and end points of programs to be repeated are set here. The start and end point settings can be designated in three stages. Automatic execution is performed in the following sequence: Start point 1 → end point 1 → start point 2 → end point 2 → start point 3 → end point 3.</p> <p><When Group has been selected as the Mode setting></p>  <p>Group No.: The number of the group to be executed automatically is set here.</p> <p>Interval The time during which each pattern is to be displayed is set here from 0 to 999 seconds. When 0 is set, execution accords with the group data setting. If the interval is not set in the group data, 0 seconds will be set.</p>
(5)	For automatic execution, select EXECUTE using  or   , and then press  . To cancel automatic execution at any time, press  .	

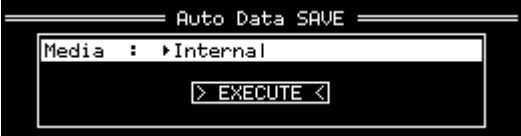
(6)	<p>Select Auto Data SAVE using  →  </p> <p>or  INC  DEC .</p>	
(7)	<p>Select the save destination (*) at Media using  or  INC  DEC, and then press .</p> <p>Select EXECUTE using  or  INC  DEC, and then press .</p>	 <p>* Internal: The data is saved on the internal memory. CF-card: The data is saved on the CF card.</p>

2.6 Displays appearing on the VG-871B / 874 fluorescent display tube

The following information appears on the VG-871B/874 fluorescent display tube.

When selecting and executing programs	
Standard display	Name of program or pattern (max. 16 characters) (With TIM at OFF)
SAMPLE, TIM and PAT key statuses ON: S T P OFF: +	Program number
Pattern drawing bit length, horizontal sync frequency, vertical sync frequency	HDCP ON/OFF ON: flashing OFF: no flashing
Group execution	
Group number	Number of program in group
When selecting groups	
Group name	Group number
When adjusting the digital video levels	
Digital video level	

3

TIMING DATA SETTINGS

3.1 Horizontal timing data editing

3.1.1 Horizontal timing data

When making changes with the horizontal timing data, the parameters which can be set and the names of the parameters are indicated below.

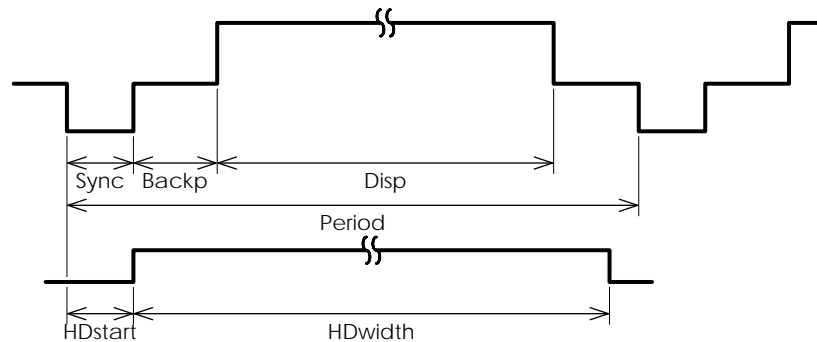

3.1.2 Restrictions on the horizontal timing parameters

The table below shows the restrictions on the parameters which can be changed with the horizontal timing data.

Setting item	Setting range	Parameter fixing function
Dot Clock	0.100 to 1360.000 MHz * Depending on the number of bits which are output, the dot clock frequency is subject to some restrictions. For details, refer to "11.1.1 Common specifications."	
Period	Time display: 0.00 to 999.999 μ s Dot display: 128 to 8192 dots	μ s setting fixed using SHIFT+2 dot setting fixed using SHIFT+3
Disp	Time display: 0.00 to 999.999 μ s Dot display: 48 to 4096 dot	μ s setting fixed using SHIFT+0 dot setting fixed using SHIFT+1
Backp, Sync	Time display: 0.00 to 999.999 μ s Dot display: 0 to 8192 dot	
HDstart, HDwidth	Time display: 0.00 to 999.999 μ s Dot display: 0 to 8190 dot	

* When a parameter is fixed, it is accompanied by an asterisk (*). Even when values other than ones for parameters with an asterisk have been changed, the values of the parameters with the asterisks remain fixed.

Example: When us setting has been fixed using SHIFT+2 for Period

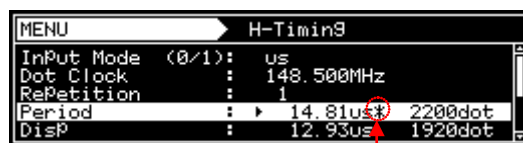

An asterisk is displayed here when the value is fixed.























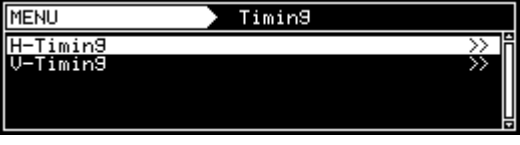

When items are set in microseconds (μ s), restrictions apply to these settings depending on the dot clock frequency and other timing data used for drawing.

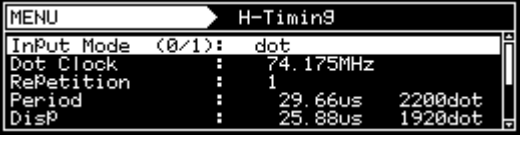
The values for the blanking and frontp items are calculated automatically on the basis of the data presented above.

Item	Calculation formula	Setting range
Blanking	Blanking = Period - Disp	Time display: 0.00 to 999.999 μ s Dot display: 40 to 8192 dots
Frontp	Frontp = Period - Disp - Sync - Backp	Time display: 0.00 to 999.999 μ s Dot display: 0 to 8192 dots

3.1.3 Horizontal timing data setting procedure

Described below is the procedure used to set the parameters which can be changed with the horizontal timing data

<p>(1) Select Program Edit using   or  , and then press .</p>																	
<p>(2) Select Timing (TIM) using  or  , and then press .</p>																	
<p>(3) Select H-Timing using  or  , and then press .</p>																	
<p><Setting the parameters></p> <p>Select the items using  or  , and then press .</p> <p>Alternatively: Select the parameter using the number keys  to , and then press .</p>	<p>Set the H-Timing parameters.</p> <table border="1"> <tbody> <tr> <td>Input Mode</td> <td>Select the input setting for the H-Timing parameters to μs: time [microseconds] or dot: number of dots [dots].</td> </tr> <tr> <td>Dot Clock</td> <td>The dot clock frequency (MHz) is set here.</td> </tr> <tr> <td>Repetition</td> <td>The number of repetitions is set here. The pixel configuration depends on the number which is set in Repetition. When 2 is set for Repetition and 1440 for Disp, the number of pixels will be 720.</td> </tr> <tr> <td>Period</td> <td>The total number of pixels in the horizontal direction is set here. <When μs: time (microseconds) has been selected as the Input Mode setting> It is possible to establish settings using both μs and dot parameters.</td> </tr> <tr> <td>Disp</td> <td>Set the Disp width in the horizontal direction here. <When μs: time (microseconds) has been selected as the Input Mode setting> It is possible to establish settings using both μs and dot parameters.</td> </tr> <tr> <td>Sync</td> <td>Set the Sync width in the horizontal direction here.</td> </tr> <tr> <td>BackP</td> <td>Set the BackP width in the horizontal direction here.</td> </tr> <tr> <td>HDStart HDWidth</td> <td>These parameters can be set only when the parallel unit has been installed.</td> </tr> </tbody> </table>	Input Mode	Select the input setting for the H-Timing parameters to μ s: time [microseconds] or dot: number of dots [dots].	Dot Clock	The dot clock frequency (MHz) is set here.	Repetition	The number of repetitions is set here. The pixel configuration depends on the number which is set in Repetition. When 2 is set for Repetition and 1440 for Disp, the number of pixels will be 720.	Period	The total number of pixels in the horizontal direction is set here. <When μs: time (microseconds) has been selected as the Input Mode setting> It is possible to establish settings using both μ s and dot parameters.	Disp	Set the Disp width in the horizontal direction here. <When μs: time (microseconds) has been selected as the Input Mode setting> It is possible to establish settings using both μ s and dot parameters.	Sync	Set the Sync width in the horizontal direction here.	BackP	Set the BackP width in the horizontal direction here.	HDStart HDWidth	These parameters can be set only when the parallel unit has been installed.
Input Mode	Select the input setting for the H-Timing parameters to μ s: time [microseconds] or dot: number of dots [dots].																
Dot Clock	The dot clock frequency (MHz) is set here.																
Repetition	The number of repetitions is set here. The pixel configuration depends on the number which is set in Repetition. When 2 is set for Repetition and 1440 for Disp, the number of pixels will be 720.																
Period	The total number of pixels in the horizontal direction is set here. <When μs: time (microseconds) has been selected as the Input Mode setting> It is possible to establish settings using both μ s and dot parameters.																
Disp	Set the Disp width in the horizontal direction here. <When μs: time (microseconds) has been selected as the Input Mode setting> It is possible to establish settings using both μ s and dot parameters.																
Sync	Set the Sync width in the horizontal direction here.																
BackP	Set the BackP width in the horizontal direction here.																
HDStart HDWidth	These parameters can be set only when the parallel unit has been installed.																

3.2 Vertical timing data editing

The vertical timing setting locations and names of the settings are indicated below.

3.2.1 Vertical timing data

[For progressive scanning]

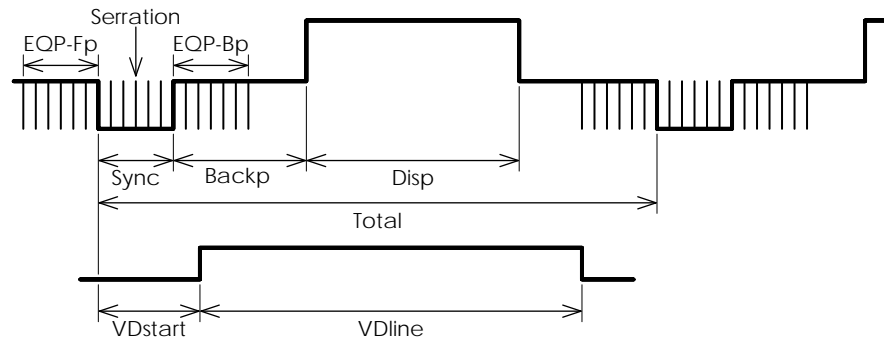

[For interlaced scanning]

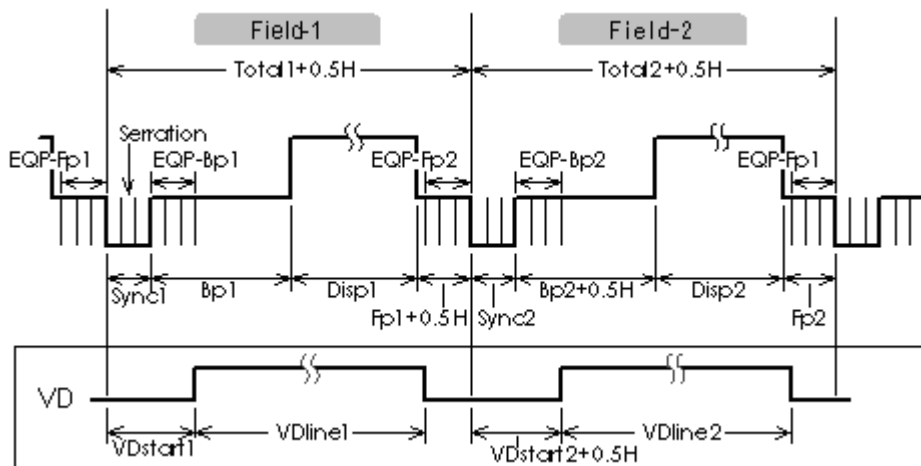

3.2.2 Restrictions on the vertical timing parameters

The table below shows the restrictions on the parameters which can be changed with the vertical timing data.

<For progressive scanning>

Setting item	Setting range	Parameter fixing function
Total	Time display: 0.00 to 999.999 ms Dot display: 8 to 8192 H	ms setting fixed using SHIFT+2 H setting fixed using SHIFT+3
Disp	Time display: 0.00 to 999.999 ms Dot display: 2 to 4096 H	ms setting fixed using SHIFT+0 H setting fixed using SHIFT+1
Sync	Time display: 0.00 to 999.999 ms Dot display: 1 to 99 H	
Backp	Time display: 0.00 to 999.999 ms Dot display: 1 to 8192 H	
VDstart , VDline	Time display: 0.00 to 999.999 ms Dot display: 0 to 8190 H	

<For interlaced scanning>

Setting item	Setting range	Parameter fixing function
Field-1 Total1	Time display: 0.00 to 999.999 ms Dot display: 4.0 to 4096.0 H (in 0.5H increments)	Fixed to ms setting using SHIFT+2 Fixed to H setting using SHIFT+3
Disp1	Time display: 0.00 to 999.999 ms Dot display: 1 to 2048 H	Fixed to ms setting using SHIFT+0 Fixed to H setting using SHIFT+1
Sync1	Time display: 0.00 to 999.999 ms Dot display: 1.0 to 99.0 H (in 0.5H increments)	
Backp1	Time display: 0.00 to 999.999 ms Dot display: 0.0 to 4096.0 H (in 0.5H increments)	
VDstart1	Time display: 0.00 to 999.999 ms Dot display: 0.0 to 4095.0 H (in 0.5H increments)	
VDline1	Time display: 0.00 to 999.999 ms Dot display: 0.0 to 4095.0 H (in 0.5H increments)	
Field-2 Total2	Same as Field-1	Same as Field-1
Disp2		
Sync2		
Backp2		
VDstart2		
VDline2		

* When a parameter is fixed, it is accompanied by an asterisk (*). Even when values other than ones for parameters with an asterisk have been changed, the values of the parameters with the asterisks remain fixed.

Example: When an ms setting has been fixed using SHIFT+2 for Total

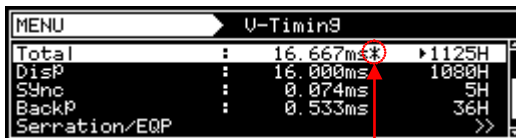

An asterisk is displayed here when the value is fixed.



When the time display (ms) is set for the items, restrictions apply to these settings depending on the H-period and other timing data used for drawing.

The values for the blanking and frontp items are calculated automatically on the basis of the data presented above.

<For progressive scanning>





























Item	Calculation formula	Setting range
Blanking	$\text{Blanking} = \text{Total} - \text{Disp}$	Time display: 0.00 to 999.999 ms Dot display: 2 to 8192 H
Frontp	$\text{Frontp} = \text{Total} - \text{Disp} - \text{Sync} - \text{Backp}$	Time display: 0.00 to 999.999 ms Dot display: 0 to 8192 H

<For interlaced scanning>

Item	Calculation formula	Setting range
Frontp1 (Frontp2)	$\text{Frontp1} = \text{Total2} - \text{Disp2} - \text{Sync2} - \text{Backp2}$ $(\text{Frontp2} = \text{Total1} - \text{Disp1} - \text{Sync1} - \text{Backp1})$	Time display: 0.00 to 999.999 ms Dot display: 0.0 to 4096.0 H
Blanking1 (Blanking2)	$\text{Blanking1} = \text{Frontp1} + \text{Sync1} + \text{Backp1}$ $(\text{Blanking2} = \text{Frontp2} + \text{Sync2} + \text{Backp2})$	Time display: 0.00 to 999.999 ms Dot display: 2.0 to 4096.0 H

3.2.3 Vertical timing data setting procedure

Described below is the procedure used to set the parameters which can be changed with the vertical timing data.

<p>(1) Select Program Edit using    or  , and then press .</p>	 <pre> MENU Program Edit Program Name : ▶EIA1920x1080P360 Timing (TIM) < TIM > >> Output (TIM) < TIM > >> Audio (TIM) < TIM > >> Pattern (PAT) < PAT > >> </pre>																		
<p>(2) Select Timing (TIM) using   or  , and then press .</p>	 <pre> MENU Timing H-Timing < TIM > >> U-Timing < TIM > >> </pre>																		
<p>(3) Select V-Timing using   or  , and then press .</p>	 <pre> MENU V-Timing Input Mode (0/1): ▶H Scan (0-3): Progressive TV Mode (0-B): HDTV1080 Total : 16.667ms 1125H Disp : 16.000ms 1080H </pre>																		
<p>Select the items using   or  , and then press .</p> <p>Select the parameter using the number keys ( to ) , and then press .</p> <p>* In the case of interlaced scanning outputs, Total, Disp, Sync and BackP are set for both Field1 and Field2.</p>	<p>Set the V-Timing parameters.</p> <table border="1"> <tbody> <tr> <td data-bbox="751 860 906 958">Input Mode</td> <td data-bbox="911 860 1380 958">Select the input setting for the V-Timing parameters to ms: time [milliseconds] or H: number of lines [H].</td> </tr> <tr> <td data-bbox="751 965 906 1019">Scan</td> <td data-bbox="911 965 1380 1019">Refer to “3.2.4 Concerning the scanning modes.”</td> </tr> <tr> <td data-bbox="751 1025 906 1115">TV Mode</td> <td data-bbox="911 1025 1380 1115">As a general rule, do not change this setting. For further details, refer to “3.2.5 Concerning the TV modes.”</td> </tr> <tr> <td data-bbox="751 1122 906 1176">Total</td> <td data-bbox="911 1122 1380 1176">The Total number in the vertical direction is set here.</td> </tr> <tr> <td data-bbox="751 1182 906 1236">Disp</td> <td data-bbox="911 1182 1380 1236">The Disp width in the vertical direction is set here.</td> </tr> <tr> <td data-bbox="751 1243 906 1296">Sync</td> <td data-bbox="911 1243 1380 1296">The Sync width in the vertical direction is set here.</td> </tr> <tr> <td data-bbox="751 1303 906 1357">BackP</td> <td data-bbox="911 1303 1380 1357">The BackP width in the vertical direction is set here.</td> </tr> <tr> <td data-bbox="751 1364 906 1417">Serration/EQP</td> <td data-bbox="911 1364 1380 1417">Refer to “3.2.6 Concerning Serration and EQP.”</td> </tr> <tr> <td data-bbox="751 1424 906 1498">VD</td> <td data-bbox="911 1424 1380 1498">Set VDStart and VDline here. This parameter can be set only when the parallel board has been installed.</td> </tr> </tbody> </table>	Input Mode	Select the input setting for the V-Timing parameters to ms: time [milliseconds] or H: number of lines [H].	Scan	Refer to “3.2.4 Concerning the scanning modes.”	TV Mode	As a general rule, do not change this setting. For further details, refer to “3.2.5 Concerning the TV modes.”	Total	The Total number in the vertical direction is set here.	Disp	The Disp width in the vertical direction is set here.	Sync	The Sync width in the vertical direction is set here.	BackP	The BackP width in the vertical direction is set here.	Serration/EQP	Refer to “3.2.6 Concerning Serration and EQP.”	VD	Set VDStart and VDline here. This parameter can be set only when the parallel board has been installed.
Input Mode	Select the input setting for the V-Timing parameters to ms: time [milliseconds] or H: number of lines [H].																		
Scan	Refer to “3.2.4 Concerning the scanning modes.”																		
TV Mode	As a general rule, do not change this setting. For further details, refer to “3.2.5 Concerning the TV modes.”																		
Total	The Total number in the vertical direction is set here.																		
Disp	The Disp width in the vertical direction is set here.																		
Sync	The Sync width in the vertical direction is set here.																		
BackP	The BackP width in the vertical direction is set here.																		
Serration/EQP	Refer to “3.2.6 Concerning Serration and EQP.”																		
VD	Set VDStart and VDline here. This parameter can be set only when the parallel board has been installed.																		

3.2.4 Concerning the scanning modes

The table below lists the V-Timing scan settings as well as the operations for the scanning methods supported by the settings, imaging methods and action settings.

Scan mode	System	Pixel imaging	Scroll and other actions
Progressive	Progressive scanning	Different pixels are drawn on each line.	Operation is performed for each frame.
Interlace	Interlaced scanning	Different pixels are drawn in the first field and second field.	Operation is performed for each field.
Prog.Segmented Frame	Interlaced scanning	Different pixels are drawn in the first field and second field.	Operation is performed for each frame (2 fields).
Interlace (Sync)	Interlaced scanning	The same image is repeatedly drawn in the first field and second field.	Operation is performed for each field.

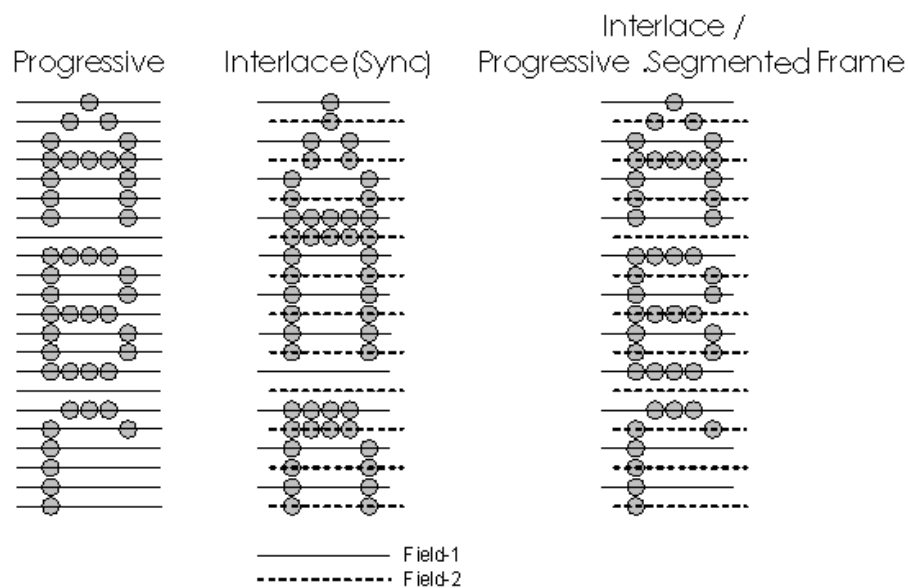

3.2.5 Concerning the TV modes

This parameter indicates the output of the TV standard signals (NTSC, NTSC-M, NTSC-443, PAL, PAL-M, PAL-60, PAL-N, PAL-Nc, SECAM, HDTV1080 or HDTV 720).

Even when this parameter is changed, the timing data and other data will not be edited. For this reason, when it is changed, it will no longer be possible for the images to be drawn correctly on the monitor.

- * When editing the sample timing data using a TV Mode setting which is not 'Other,' select 'Other' as the TV mode setting. In this case, however, the tri-level sync signal will not be output.

3.2.6 Concerning Serration and EQP

Serration and EQP can be selected on the V-Timing [MENU] screen, and various parameters can be set. The correspondences between the settings and operations are described using the table below.



Serration and EQP setting procedure

Setting item	Key	LCD display	Description
Serration	0	OFF	Serrated pulses are not inserted.
	1	0.5H	Serrated pulses are inserted in increments of 0.5H.
	2	1H	Serrated pulses are inserted in increments of 1H.
	3	EXOR	HS and VS EXORs are inserted as serrated pulses.
EQP	0	OFF	Equalizing pulses are not inserted into the EQPfp and EQPbp periods.
	1	ON	Equalizing pulses are inserted into the EQPfp and EQPbp periods.

Shown below as an example is the phase relationship when a setting of 0.5H has been selected for Serration.

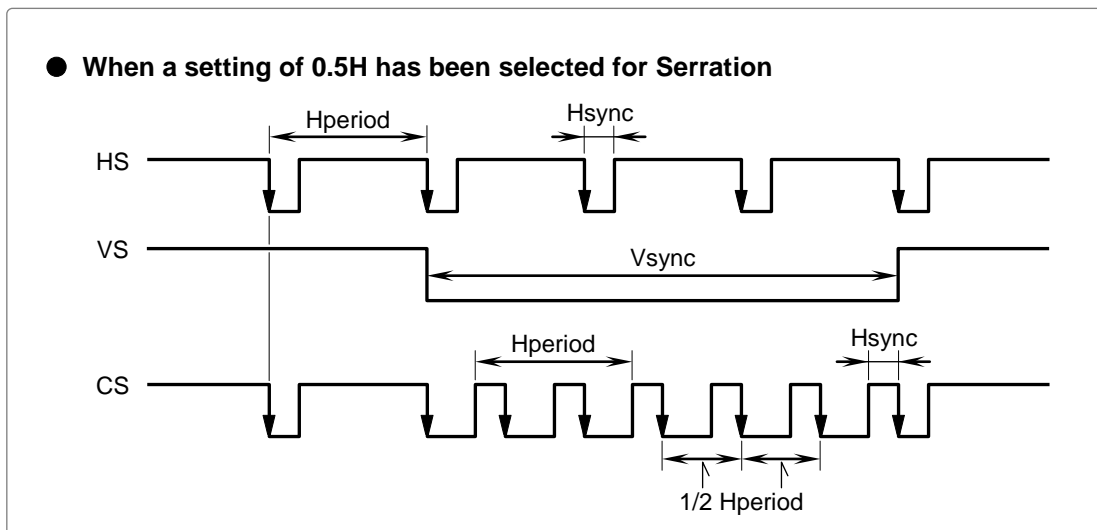

- The serration and EQP item settings are not reflected in the composite, Y/C and SCART signals.
- In the case of HDTV timing data, they are set to OFF when EXOR is selected as the serration setting item.

3.2.7 Concerning EQP-Fp and EQP-Bp

Equalizing pulses (EQP-Fp and EQP-Bp) can be selected on the V-Timing [MENU] screen, and various parameters can be set. The correspondences between the settings and operations are described using the table below.

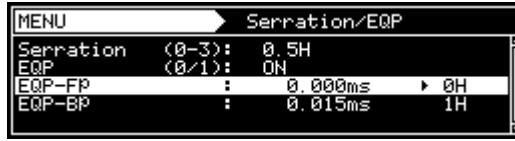

EQP-Fp/EQP-Bp setting procedure

<For progressive scanning>

Setting item	Details of setting
EQPfp	This sets the equalizing pulse inside the front porch. Setting range: 0.000 to 999.999 [ms], 0 to 99 [H]
EQPbp	This sets the equalizing pulse inside the back porch. Setting range: 0.000 to 999.999 [ms], 0 to 99 [H]

<For interlaced scanning>

Setting item	Details of setting
EQP-Fp1 (EQP-Fp2)	This sets the equalizing pulse inside the front porch. Setting range: 0.000 to 999.999 [ms], 0.0 to 99.0 [H] (in 0.5H increments)
EQP-Bp1 (EQP-Bp2)	This sets the equalizing pulse inside the back porch. Setting range: 0.000 to 999.999 [ms], 0.0 to 99.0 [H] (in 0.5H increments)



- Set EQP-Fp within the range of $[(EQP-Fp + 1H) \leq Hfrontp]$ for tri-level sync signal outputs in the interlaced scanning mode.

The figure below shows the EQP phase relationship and approach taken.

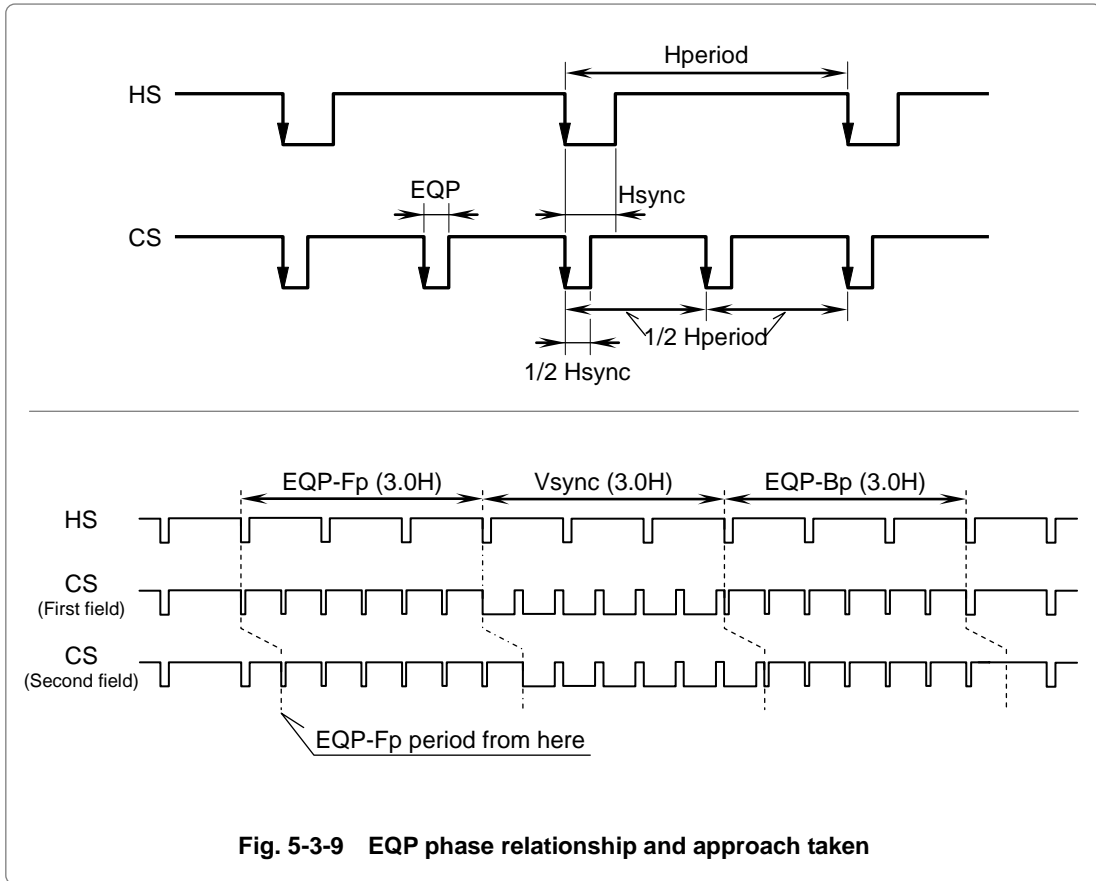

Fig. 5-3-9 EQP phase relationship and approach taken

Example: Four examples of the EQP-Fp, EQP-Bp, EQP and Serration settings are shown below.

<Setting example 1>

Setting item	Setting
EQP-Fp	0H
EQP-Bp	0H
EQP	OFF
Serration	OFF

<Setting example 2>

Setting item	Setting
EQP-Fp	0H
EQP-Bp	0H
EQP	OFF
Serration	0.5H

<Setting example 3>

Setting item	Setting
EQP-Fp	3H
EQP-Bp	3H
EQP	ON
Serration	1H

<Setting example 4>

Setting item	Setting
EQP-Fp	3H
EQP-Bp	0H
EQP	OFF
Serration	OFF

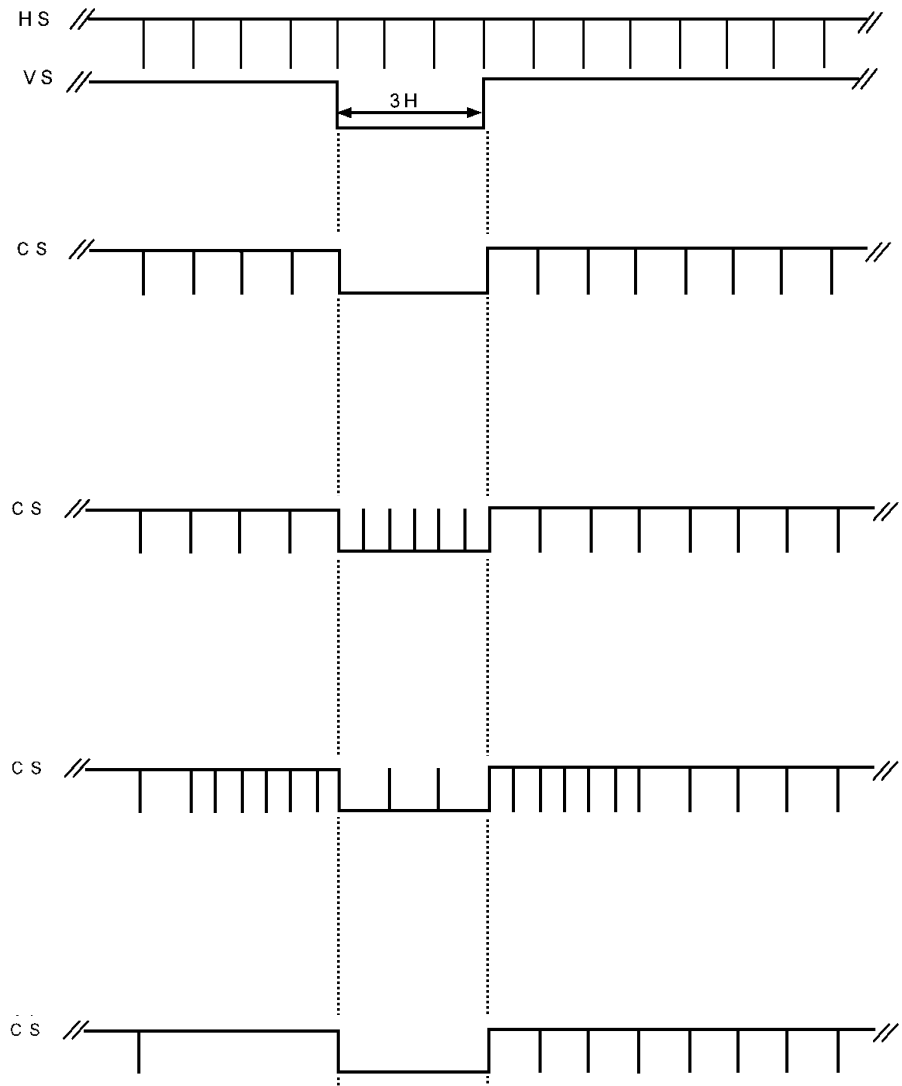

4

INTERFACE SETTINGS

4.1 Output settings





















The following items are set as settings common to multiple video and audio output interfaces.





- Output interface on/off setting
- Sync signal on/off and polarity setting
- Level mode setting
- Aspect ratio setting
- Pattern drawing bit length (gray scale) setting
- RGB/YpBPr selection and color difference coefficient setting
- Analog level setting
- Digital level setting
- Audio sweep setting
- Audio level setting (temporary settings)

4.1.1 Setting the output interfaces to ON or OFF





“Output” (ON) or “not output” (OFF) can be selected for each output interface whether video or audio interface. It is set to ON for the internal sample timing data unless the ratings or specifications of the generator prevent this.

Example: In the case of EIA 1920 x 1080i@59.94, the COMPOSITE and Y/C signals are set to OFF, but the HDMI and analog component signals are set to ON.

(1)	Select Program Edit using  or  , and then press  .	
(2)	Select Output (TIM) using  or  , and then press  .	
(3)	Select All Output using  or  , and then press  .	
(4)	Select Output OFF/ON using  or  , and then press  .	 <p>PC, TV, etc. are types of interfaces.</p>
(5)	Select the interface whose settings are to be changed using  or  or  , and then press  .	





























<p>(6) Select OFF/ON using  or  , and then press .</p>	
---	--

<How to check the interfaces whose signals are output>

<p>(1) On the initial screen, select  while holding down . Select  again while holding down  to exit from the OUTPUT STATUS screen.</p>	
--	--

4.1.2 Setting the sync signals to ON or OFF and setting the sync signal polarities

In this section, the sync signals are set to ON or OFF and the sync signal polarities are set for each output connector.

<p>(1) Select Program Edit using   or  , and then press .</p>	
<p>(2) Select Output (TIM) using  or , and then press .</p>	
<p>(3) Select All Output using  or , and then press .</p>	
<p>(4) Select Sync using  or  , and then press .</p>	
<p>(5) Select the items using  or  , and then press .</p> <p>Select the parameters using  or  , and then press .</p>	<p>HS/VS/CS and CV is set here.</p> <p>* CV is a sync signal overlapping on analog video signal from RGB/YpbPr connectors and it denotes "Video-on-Sync" and this manual.</p> <p>For further details, refer to <Sync setting parameters> on the next page.</p>
<p>(6) </p>	<p>Display returns to the initial screen.</p>

<Sync setting parameters>

HS	Used to set the HS connector output.	
	0	Off No output
	1	Nega The signal is output with a negative polarity.
	2	Posi The signal is output with a positive polarity.
VS	Used to set the VS connector output.	
	0	Off No output
	1	Nega The signal is output with a negative polarity.
	2	Posi The signal is output with a positive polarity.
CS	Used to set the CS connector output.	
	0	Off No output
	1	Nega The signal is output with a negative polarity.
	2	Posi The signal is output with a positive polarity.
CV	Used to set whether to superimpose Video-on-Sync onto the analog component signals.	
	0	Off Video-on-Sync is not superimposed.
	1	R Video-on-Sync is superimposed onto the R analog component signal.
	2	G Video-on-Sync is superimposed onto the G analog component signal.
	3	RG Video-on-Sync is superimposed onto the RG analog component signal.
	4	B Video-on-Sync is superimposed onto the B analog component signal.
	5	RB Video-on-Sync is superimposed onto the RB analog component signal.
	6	GB Video-on-Sync is superimposed onto the GB analog component signal.
7	RGB Video-on-Sync is superimposed onto the RGB analog component signal.	





















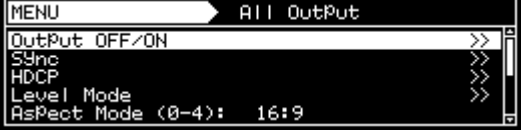

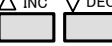

- If the CS signal is a tri-level sync (HDTV timing) signals, its polarity cannot be changed.

4.1.3 Setting the level mode

Images can be output in the “limited” range of the HDMI standard. The output image range can be set for each unit. The same level setting can also be established using an interface which is not HDMI (such as DVI, LVDS, parallel or analog).

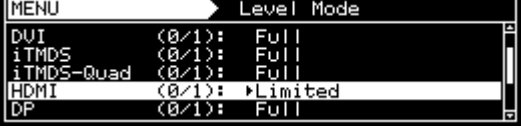
* With the analog interface, the gray scale of the video parts will change, but neither the pedestal level nor peak level will change from when the “full” range applies.

<p>(1) Select Program Edit using  or , and then press .</p>	
<p>(2) Select Output (TIM) using  or , and then press .</p>	
<p>(3) Select All Output using  or , and then press .</p>	
<p>(4) Select Level Mode using  or , and then press .</p>	
<p>(5) Select the unit using  or , and then press .</p> <p>Select “limited” or “full” using  or , and then press .</p>	
<p>(6) Select .</p>	<p>Display returns to the initial screen.</p>

Video range when “full” is selected

























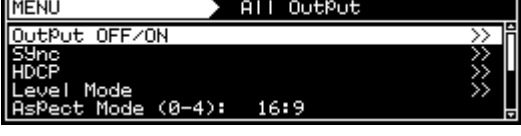







	8 BIT	10BIT	12BIT	16BIT
R/G/B/Y/Cb/Cr	0-255	0-1023	0-4095	0-65535











Video range when “Limited” is selected

	8BIT	10BIT	12BIT	16BIT
R/G/B/Y	16-235	64-940	256-3760	4096-60160
Cb/Cr	16-240	64-960	256-3840	4096-61440

4.1.4 Setting the aspect ratio

In this section, the aspect ratio of the video signals is set.

<p>(1) Select Program Edit using  →  or  , and then press .</p>																
<p>(2) Select Output (TIM) using  or  , and then press .</p>																
<p>(3) Select All Output using  or  , and then press .</p>																
<p>(4) Select Aspect Mode using  or  , and then press .</p>																
<p>(5) <Inputting the parameters> Select the parameters using  or  , and then press  Alternatively: Select the parameters using the number keys ( to ), and then press .</p>	<p>Set the aspect ratio.</p> <table border="1" data-bbox="863 1050 1498 1274"> <tr> <td>0</td> <td>4:3</td> <td>The aspect ratio is set to 4:3.</td> </tr> <tr> <td>1</td> <td>4:3 Letter Box</td> <td>The aspect ratio is set to 4:3 letter box.</td> </tr> <tr> <td>2</td> <td>16:9</td> <td>The aspect ratio is set to 16:9.</td> </tr> <tr> <td>3</td> <td>Resolution</td> <td>The aspect ratio is set to the same ratio as the screen resolution.</td> </tr> <tr> <td>4</td> <td>User</td> <td>The aspect ratio of the user's choice is set.</td> </tr> </table> <p>* The 4:3 letter box setting takes effect only with SDTV timing signals.</p>	0	4:3	The aspect ratio is set to 4:3.	1	4:3 Letter Box	The aspect ratio is set to 4:3 letter box.	2	16:9	The aspect ratio is set to 16:9.	3	Resolution	The aspect ratio is set to the same ratio as the screen resolution.	4	User	The aspect ratio of the user's choice is set.
0	4:3	The aspect ratio is set to 4:3.														
1	4:3 Letter Box	The aspect ratio is set to 4:3 letter box.														
2	16:9	The aspect ratio is set to 16:9.														
3	Resolution	The aspect ratio is set to the same ratio as the screen resolution.														
4	User	The aspect ratio of the user's choice is set.														
<p>(6) If User was set in step (5), users can set the aspect ratio of their choice. Select UserAspect using  or  , and then press .</p>																

(7)	<Inputting the parameters> Select the parameters using  or   , and then press  . Select the numerical value using  or   , and then press  . Alternatively: Select the parameters using the number keys  to  , and then press  .	Set the aspect ratio.	
		H	The aspect ratio is set in the horizontal direction. Setting range: 0 to 255
		V	The aspect ratio is set in the vertical direction. Setting range: 0 to 255

* Although images are normally output with the 4:3 aspect ratio, the images which are output when 4:3 letter box has been selected will be in the 16:9 aspect ratio. For this reason, the top and bottom of the images are filled in with black and output. When 4:3 letter box has been selected as the aspect ratio, the images output will appear as shown below.

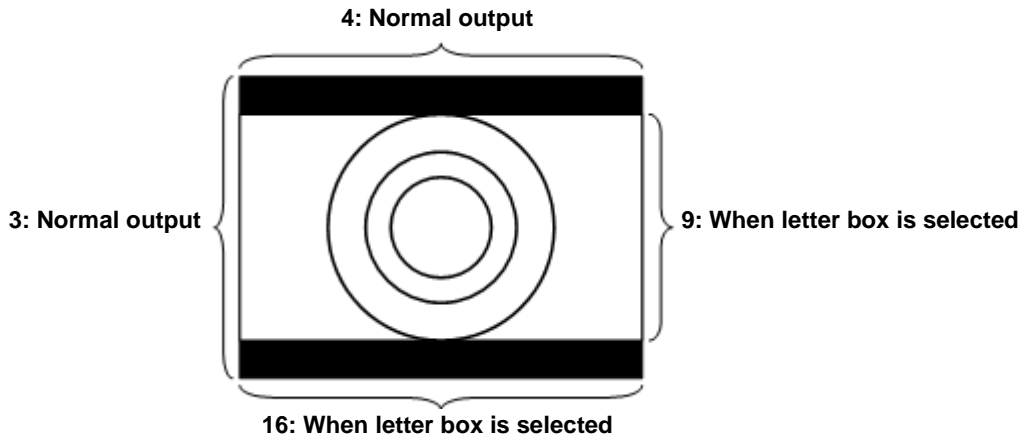





















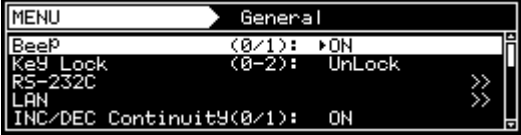

4.1.5 Setting the bit length (gray scale) for pattern drawing

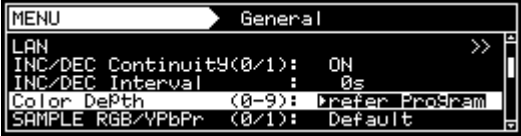
The bit length (gray scale) applying when drawing test patterns can be set.

It can either be set either separately for each program or it can be fixed irrespective of the programs.













- The same specific bit length is designated.
- The bit length is set for each program.



























a) Designating the same specific bit length

<p>(1) Select Configuration using    or  , and then press .</p>																															
<p>(2) Select General using  or  , and then press .</p>																															
<p>(3) Select Color Depth using  or  , and then press .</p>																															
<p>(4) <Inputting the parameters> Select the parameters using  or  , and then press . Alternatively: Select the parameters using the number keys ( to ) , and then press .</p>	<p>Select the bit length.</p> <table border="1" data-bbox="863 1019 1489 1382"> <tbody> <tr> <td>0</td> <td>Refer to Program</td> <td>The setting matches the program setting.</td> </tr> <tr> <td>1</td> <td>8 Bit</td> <td>The patterns are drawn with 8 bits.</td> </tr> <tr> <td>2</td> <td>9 Bit</td> <td>The patterns are drawn with 9 bits.</td> </tr> <tr> <td>3</td> <td>10 Bit</td> <td>The patterns are drawn with 10 bits.</td> </tr> <tr> <td>4</td> <td>11 Bit</td> <td>The patterns are drawn with 11 bits.</td> </tr> <tr> <td>5</td> <td>12 Bit</td> <td>The patterns are drawn with 12 bits.</td> </tr> <tr> <td>6</td> <td>13 Bit</td> <td>The patterns are drawn with 13 bits.</td> </tr> <tr> <td>7</td> <td>14 Bit</td> <td>The patterns are drawn with 14 bits.</td> </tr> <tr> <td>8</td> <td>15 Bit</td> <td>The patterns are drawn with 15 bits.</td> </tr> <tr> <td>9</td> <td>16 Bit</td> <td>The patterns are drawn with 16 bits.</td> </tr> </tbody> </table>	0	Refer to Program	The setting matches the program setting.	1	8 Bit	The patterns are drawn with 8 bits.	2	9 Bit	The patterns are drawn with 9 bits.	3	10 Bit	The patterns are drawn with 10 bits.	4	11 Bit	The patterns are drawn with 11 bits.	5	12 Bit	The patterns are drawn with 12 bits.	6	13 Bit	The patterns are drawn with 13 bits.	7	14 Bit	The patterns are drawn with 14 bits.	8	15 Bit	The patterns are drawn with 15 bits.	9	16 Bit	The patterns are drawn with 16 bits.
0	Refer to Program	The setting matches the program setting.																													
1	8 Bit	The patterns are drawn with 8 bits.																													
2	9 Bit	The patterns are drawn with 9 bits.																													
3	10 Bit	The patterns are drawn with 10 bits.																													
4	11 Bit	The patterns are drawn with 11 bits.																													
5	12 Bit	The patterns are drawn with 12 bits.																													
6	13 Bit	The patterns are drawn with 13 bits.																													
7	14 Bit	The patterns are drawn with 14 bits.																													
8	15 Bit	The patterns are drawn with 15 bits.																													
9	16 Bit	The patterns are drawn with 16 bits.																													







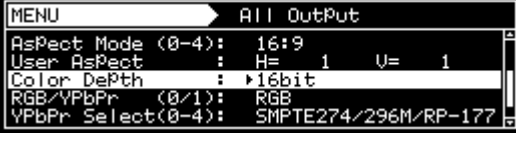



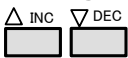













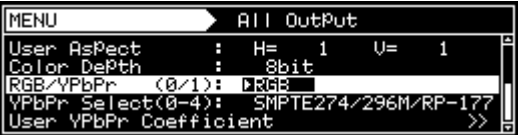

b) Setting the bit length for each program







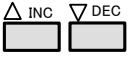

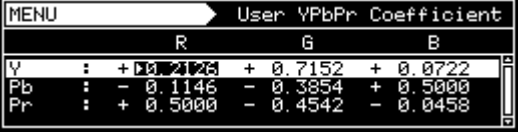





This setting takes effect when “Refer to Program” has been selected for the setting in (3) of “Designating the same specific bit length” in a) above.

<p>(1) Select Program Edit using    or  , and then press .</p>	
<p>(2) Select Output (TIM) using  or  , and then press .</p>	

(3)	<p>Select All Output using  or   or .</p> <p>Select All Output using  or   or .</p>	 <pre> MENU All OutPut OutPut OFF/ON >> Sync >> HDCP >> Level Mode >> AsPect Mode (0-4): 16:9 </pre>
(4)	<p>Select Color Depth using  or   or .</p> <p>Select Color Depth using  or   or .</p>	 <pre> MENU All OutPut AsPect Mode (0-4): 16:9 User AsPect : H= 1 U= 1 Color Depth : 16bit RGB/VPbPr (0/1): RGB VPbPr Select(0-4): SMPTE274/296M/RP-177 </pre>
(5)	<p>Select the bit length using  or   or .</p> <p>Select the bit length using  or   or .</p>	 <pre> MENU All OutPut AsPect Mode (0-4): 16:9 User AsPect : H= 1 U= 1 Color Depth : 16bit RGB/VPbPr (0/1): RGB VPbPr Select(0-4): SMPTE274/296M/RP-177 </pre>

4.1.6 Selecting RGB or YPbPr and setting the color difference coefficients

<p>(1) Select Program Edit using  or , and then press .</p>														
<p>(2) Select Output (TIM) using  or , and then press .</p>														
<p>(3) Select All Output using  or , and then press .</p>														
<p>(4) Select RGB/YPbPr using  or , and then press .</p> <p>Select the parameters using  or , and then press .</p>	<p>Select the color difference coefficients (YPbPr) or RGB.</p>  <table border="1" data-bbox="858 992 1498 1093"> <tr> <td>0</td> <td>RGB</td> <td>The signals are output as RGB signals.</td> </tr> <tr> <td>1</td> <td>YPbPr</td> <td>The signals are output as YPbPr signals.</td> </tr> </table> <p>* The RGB or YPbPr signals of the HDMI unit cannot be changed using this menu. For further details on how to change these signals, refer to "4.2.2 HDMI setting procedure"</p>	0	RGB	The signals are output as RGB signals.	1	YPbPr	The signals are output as YPbPr signals.							
0	RGB	The signals are output as RGB signals.												
1	YPbPr	The signals are output as YPbPr signals.												
<p>(5) When YPbPr was selected in step (4), select the color difference coefficients.</p> <p>Select YPbPr Select using  or , and then press .</p> <p>Select the parameters using  or , and then press .</p>	<p>Select the color difference coefficients.</p> <table border="1" data-bbox="858 1238 1498 1462"> <tr> <td>0</td> <td>SMPTE274M/296M/RP-177</td> <td rowspan="3">The color difference coefficients of one of the standards on the left are set.</td> </tr> <tr> <td>1</td> <td>SMPTE-240M</td> </tr> <tr> <td>2</td> <td>SMPTE-293M</td> </tr> <tr> <td>3</td> <td>SMPTE-125M</td> <td></td> </tr> <tr> <td>4</td> <td>User</td> <td>The coefficients of the user's choice are set.</td> </tr> </table>	0	SMPTE274M/296M/RP-177	The color difference coefficients of one of the standards on the left are set.	1	SMPTE-240M	2	SMPTE-293M	3	SMPTE-125M		4	User	The coefficients of the user's choice are set.
0	SMPTE274M/296M/RP-177	The color difference coefficients of one of the standards on the left are set.												
1	SMPTE-240M													
2	SMPTE-293M													
3	SMPTE-125M													
4	User	The coefficients of the user's choice are set.												
<p>(6) If YPbPr was selected in step (4) and User in step (5), users can set the coefficient of their own choice.</p> <p>Select UserYPbPr Coefficient using  or , and then press .</p>														

(7)	<p>Select the color matrix coefficients.</p> <p>Select the parameters using  or   or  , and then press .</p> <p>Select the numerical value using  or  , and then press .</p> <p>Alternatively: Select the parameters using the number keys  to , and then press .</p>	<p>Caution for setting the coefficients</p> <ul style="list-style-type: none"> • The Y line must total 1.0000. • The sum of the coefficient for Pb and Pr respectively must be 0.
(8)	<p>Select .</p>	<p>Display returns to the initial screen.</p>













4.1.7 Setting the analog level

In this section, the video level of the analog component signals is set.

The video signal gray scale remains unchanged, and only the level is changed.

There are two ways to set the analog input level: One uses the LEVEL key screen, and the other is from Program Edit.

<How to set the analog input level on the LEVEL key screen>

(1)	<p>Set the analog video level using  →</p> <p></p>	
(2)	<p>Change the analog level using  or</p> <p> </p> <p><When increasing the setting speed> Change the analog level (more quickly) using</p> <p> +  or  +  </p>	<p>Setting range:</p> <p>When Video-on-Sync is not superimposed 0.05 V - 1.2 V</p> <p>When Video-on-Sync is superimposed 0.30 V - 1.2 V</p> <p>For the Video-on-Sync setting, refer to “4.1.2 Setting the sync signals to ON or OFF and setting the sync signal polarities.”</p>
(3)	<p>Select  or </p>	<p>Display returns to the initial screen.</p>

<How to set the analog input level from Program Edit>

Refer to section “4.7.2 Setting the analog output connectors” (**Video** parameters).



They take effect only with the component output signals of the PC analog unit.









4.1.8 Setting the digital level

In this section, the digital level of the video signals is set.

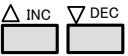



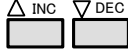







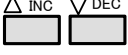

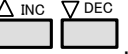

For further details on setting the gray scale, refer to “4.1.5 Setting the bit length (gray scale) for pattern drawing.”

There are two ways to set the digital input level: One uses the LEVEL key screen, and the other is from Program Edit.

<How to set the digital input level on the LEVEL key screen>





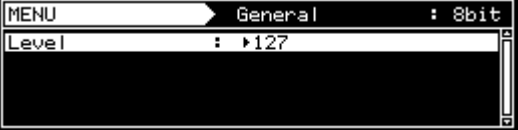





















(1)	Select  , and then set the digital video level.																					
(2)	<p>Change the digital level using  or .</p> <p><When increasing the setting speed> Change the digital level (more quickly) using  +  or  + .</p> <p>* The number of steps when increasing the setting speed can be set by the operations described in section “9.1.15 Digital Video Level Step setting.”</p>	<table border="1"> <thead> <tr> <th>Bit length (gray scale)</th> <th>Setting range</th> </tr> </thead> <tbody> <tr> <td>8BIT</td> <td>0 - 255</td> </tr> <tr> <td>9BIT</td> <td>0 - 511</td> </tr> <tr> <td>10BIT</td> <td>0 - 1023</td> </tr> <tr> <td>11BIT</td> <td>0 - 2047</td> </tr> <tr> <td>12BIT</td> <td>0 - 4095</td> </tr> <tr> <td>13BIT</td> <td>0 - 8191</td> </tr> <tr> <td>14BIT</td> <td>0 - 16383</td> </tr> <tr> <td>15BIT</td> <td>0 - 32767</td> </tr> <tr> <td>16BIT</td> <td>0 - 65535</td> </tr> </tbody> </table>	Bit length (gray scale)	Setting range	8BIT	0 - 255	9BIT	0 - 511	10BIT	0 - 1023	11BIT	0 - 2047	12BIT	0 - 4095	13BIT	0 - 8191	14BIT	0 - 16383	15BIT	0 - 32767	16BIT	0 - 65535
Bit length (gray scale)	Setting range																					
8BIT	0 - 255																					
9BIT	0 - 511																					
10BIT	0 - 1023																					
11BIT	0 - 2047																					
12BIT	0 - 4095																					
13BIT	0 - 8191																					
14BIT	0 - 16383																					
15BIT	0 - 32767																					
16BIT	0 - 65535																					
(3)	Select  or  .	Display returns to the initial screen.																				

<How to set the digital input level from Program Edit>

(1)	Using  →  or  , Select Program Edit , and then press  . Select Output (TIM) , and then press  . Select Digital Output , and then press  . Select General , and then press  .	
(2)	Select the items using  or  , and then press  . <p><Inputting the parameters></p> Select the parameters using  or  ,  , and then press  . Alternatively: Select the parameters using the number keys  to  , and then press  .	 <p>The setting ranges are the same as in the section “How to set the digital input level on the LEVEL key screen.”</p>

4.1.9 Audio sweep settings

The audio output frequency can be raised or lowered at the set interval.

(1)	<p>Select Program Edit using  →  or  INC  DEC, and then press .</p>	 <pre> MENU Program Edit Program Name : ▶EIA1920x1080P@60 Timing (TIM) >>> Output (TIM) >>> Audio (TIM) >>> Pattern (PAT) >>> </pre>
(2)	<p>Select Audio using  or  INC  DEC, and then press .</p>	 <pre> MENU Audio Analog Audio >>> Digital Audio >>> Audio Sweep >>> </pre>
(3)	<p>Select Audio Sweep using  or  INC  DEC, and then press .</p>	 <pre> MENU Audio Sweep Sweep (0/1): ▶OFF Repeat : 0 (infinity) Frequency Min : 200Hz Max : 20000Hz </pre>
(4)	<p>Select the items using  or  INC  DEC, and then press .</p> <p><Inputting the parameters></p> <p>Select the parameters using  or  INC  DEC, and then press .</p> <p>Alternatively: Select the parameters using the number keys ( to ), and then press .</p>	<p>For further details, refer to <Audio sweep setting parameters>.</p>

<Audio sweep setting parameters>

(1)	Sweep (0/1)	Used to enable or disable the sweep function.	
	0	OFF	Disable
	1	ON	Enable
(2)	Repeat (0-15)	Used to set the number of repeats.	
	0	Infinity	Repeated indefinitely.
	1-15		Repeated for the set number of times only.
(3)	Frequency Min	Used to set the minimum frequency. Setting range: 200 Hz to 20000 Hz	
(4)	Frequency Max	Used to set the maximum frequency. Setting range: 200 Hz to 20000 Hz	

















- When using the function with HDMI, select **Internal PCM** as the **Digital Audio > Source** setting.

4.1.10 Setting the audio level (temporary settings)

In this section, the audio output level is set.

The level which was set in “4.15.2 Analog audio signals” for analog audio or which was set using <Internal PCM setting parameters> in “4.2.5 Embedded audio, high bit rate audio (option)” for HDMI is 0 dB.

(1)	Select  ,  and then  (PAGE: 3 of 3)	
(2)	Change the audio level using  or   . <When increasing the setting speed> Use  +  or  +   .	
(3)	Select  or  .	Display returns to the initial screen.



- The values set here are not saved as program data.
- When they are used with HDMI, select **Internal PCM** as the **Digital Audio > Source** setting.







4.1.11 Digital level setting of 3D pattern

Digital level of 3D pattern is set by each left and right picture.
Refer to “4.1.5 Big length for pattern drawing” about level setting.



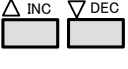
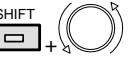
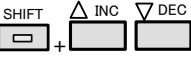





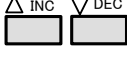

There are 2 setting method; LEVEL key screen and Program Edit.

《 LEVEL key screen 》



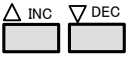

When you output 3D program, by pressing LEVEL key, it automatically shows “3D LEFT VIDEO LEVEL”

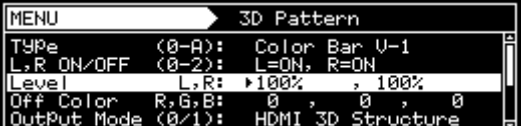

1	 → “3D LEFT VIDEO LEVEL” Press “3” to set RIGHT level.																					
2	<p>By using  or , → change video level</p> <p>《For speed up the change》</p> <p>By using  or  → step changes (speed up)</p> <p>* The changing step can be set in “9.1.15 Digital Video Level Step”.</p>	<table border="1"> <thead> <tr> <th>BIT length</th> <th>Setting range</th> </tr> </thead> <tbody> <tr><td>8BIT</td><td>0 - 255</td></tr> <tr><td>9BIT</td><td>0 - 511</td></tr> <tr><td>10BIT</td><td>0 - 1023</td></tr> <tr><td>11BIT</td><td>0 - 2047</td></tr> <tr><td>12BIT</td><td>0 - 4095</td></tr> <tr><td>13BIT</td><td>0 - 8191</td></tr> <tr><td>14BIT</td><td>0 - 16383</td></tr> <tr><td>15BIT</td><td>0 - 32767</td></tr> <tr><td>16BIT</td><td>0 - 65535</td></tr> </tbody> </table>	BIT length	Setting range	8BIT	0 - 255	9BIT	0 - 511	10BIT	0 - 1023	11BIT	0 - 2047	12BIT	0 - 4095	13BIT	0 - 8191	14BIT	0 - 16383	15BIT	0 - 32767	16BIT	0 - 65535
BIT length	Setting range																					
8BIT	0 - 255																					
9BIT	0 - 511																					
10BIT	0 - 1023																					
11BIT	0 - 2047																					
12BIT	0 - 4095																					
13BIT	0 - 8191																					
14BIT	0 - 16383																					
15BIT	0 - 32767																					
16BIT	0 - 65535																					
3		Switch LEFT / RIGHT.																				
4	Select 	Via DIGITAL LEVEL SETTING screen, it goes back to initial display.																				
5	Select 	To initial display																				

《 Setting by Program Edit 》

①	<p>By using  →  or </p> <p>Select Program Edit → </p> <p>Select Pattern(PAT) → </p> <p>Select Image / OPT → </p> <p>Select 3D Pattern → </p>	
②	<p>By using  or , select it.</p> <p>Select item → </p>	

《Parameter Input》

By using  or  , select it
→ 

Or
 -  select by number keys →

Setting range is 0 - 100 [%]

4.2 HDMI

4.2.1 Connectors and pin assignments

■ HDMI

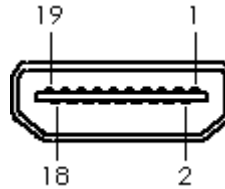

Pin no.	Signal
1	TMDS DATA2+
2	TMDS DATA2 SHIELD
3	TMDS DATA2-
4	TMDS DATA1+
5	TMDS DATA1 SHIELD
6	TMDS DATA1-
7	TMDS DATA0+
8	TMDS DATA0 SHIELD
9	TMDS DATA0-
10	TMDS CLK+
11	TMDS CLK SHIELD
12	TMDS CLK-
13	CEC
14	RESERVE / HEAC+
15	DDC CLK
16	DDC DATA
17	GROUND (for +5 V)
18	+5 V (DDC power supply *1)
19	HOT PLUG DETECT / HEAC-
Shell	FG

*1: Restrictions apply to the supply current of the DDC power supply. Refer to “**12.3 Concerning the maximum current consumption of the DDC (DP_PWR) power supply.**”

■ I2S (Option)

Connector: 7614-5002PL (made by 3M)

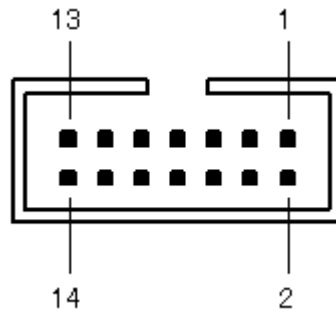





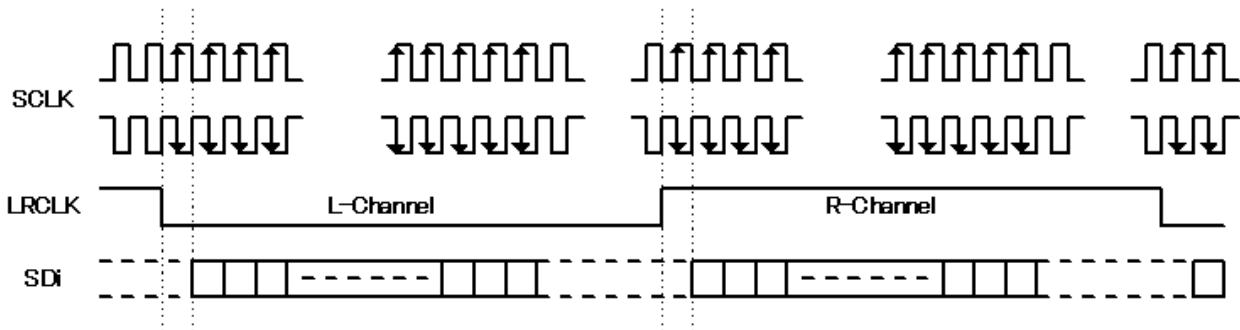















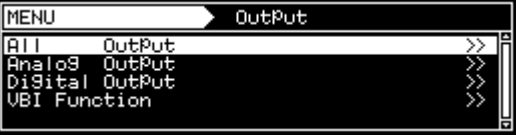











Pin no.	Signal	Description
1	MCLK IN	Input a clock signal with a frequency of 24.576 MHz or 22.5792 MHz.
2	GND	
3	SCLK IN	Input the I2S SCLK signal.
4	GND	
5	LRCLK IN	Input the I2S LRCLK signal.
6	GND	
7	SD0 IN	Input the I2S SD0 signal.
8	GND	
9	SD1 IN	Input the I2S SD1 signal.
10	GND	
11	SD2 IN	Input the I2S SD2 signal.
12	GND	
13	SD3 IN	Input the I2S SD3 signal.
14	GND	

Input the signals at the following timing.



* For the SCLK and LRCLK signals, input signals which are synchronized with MCLK. The leading edge of SCLK can be set using "4.2.5 Embedded audio, high bit rate audio (option)."

4.2.2 HDMI setting procedure

<p>(1) Select Program Edit using   or   , and then press  .</p>	
<p>(2) Select Output (TIM) using  or   , and then press  .</p>	
<p>(3) Select Digital Output using  or   , and then press  .</p>	
<p>(4) Select HDMI using  or   , and then press  .</p>	
<p>(5) Select the items using  or   , and then press  .</p> <p><Inputting the parameters></p> <p>Select the parameters using  or   , and then press  .</p> <p>Alternatively: Select the parameters using the number keys ( to ), and then press  .</p>	<p>For further details on the parameters, refer to <HDMI unit setting parameters> on the next page.</p>

<HDMI unit setting parameters>

(1)	Output 1ch (0/1) Output 2ch (0/1)	Set on or off for each channel here. The same settings as the ones described in “4.1.1 Setting the output interfaces to ON or OFF” can also be established.		
		0	Off	No signal output
		1	On	Signal output
(2)	HDMI or DVI (0-2)	An HDMI connection can be made to DVI by cable conversion. Set the operations at this time here.		
		0	HDMI	The full functions of HDMI can be used.
		1	DVI	This setting differs from HDMI in the following ways. Info Frame and Packet are not sent. Audio is not supported. <u>Up to 8 bits are supported. Deep Color is not supported. Even if “Color Depth” is set as 10-bit or higher, the actual output is 8-bit. (lower 2-bit is deleted.)</u>
2	Auto	EDID of the connected monitor is checked, and the DVI and HDMI modes are set.		
(3)	Video Format (0-2)	The color space of the images output from HDMI is set here.		
		0	RGB	The images are output using RGB signals.
		1	YCbCr4:4:4	The images are output using YCbCr4:4:4 signals.
2	YCbCr4:2:2	The images are output using YCbCr4:2:2 signals.		
(4)	Width (0-4)	The bit length of the images output from HDMI is set here. A setting independent of the bit length for pattern drawing can be selected or the same bit length can be selected automatically. * The portion by which the bit length for pattern drawing exceeds the bit length which has been set here is discarded. A deficient portion is filled with zeros. Refer to “4.1.5 Setting the bit length (gray scale) for pattern drawing.”		
		0	Auto	8, 10 or 12 bits are selected here automatically depending on the bit length for pattern drawing.
		1	8 bit	8-bit output
		2	10 bit	10-bit output
		3	12 bit	12-bit output
		4	16 bit	16-bit output (only for VM-1823)
(5)	Audio Output (0/1)	The embedded audio output is set here. * For the embedded audio settings, refer to “4.2.5 Embedded audio, high bit rate audio (option).”		
		0	Off	No embedded audio output
		1	On	Embedded audio output
(6)	Audio N (0/1)	The audio N parameter is set here. * This setting is optional. It can be set only when the CTS license has been registered. When it has not been registered, it is fixed at Auto. * VM-1823 does not support this function.		
		0	Auto	The appropriate value is set.
		1	Manual 128×fs/A	The N value, calculated using the following formula, is set: $N = 128 \times \text{sampling frequency} / A$ Where the setting range of A : 300 to 1500
(7)	InfoFrame	When sending InfoFrame automatically in line with the color space and other settings, refer to “4.2.3 InfoFrame/Packet” When sending InfoFrame with the data of the user’s choice, refer to “4.2.3 InfoFrame/Packet”		

4.2.3 InfoFrame/Packet

















InfoFrame can send the values which are optimal for the video and audio output conditions.

In addition, it is possible to send InfoFrame using values differing from the output conditions to reproduce illegal operation conditions.

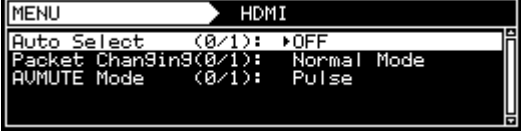
Use one of the following operations to send InfoFrame:

- a) Send the optimal values automatically.
- b) Set separate InfoFrame values, and send them.

a) Sending the optimal values automatically

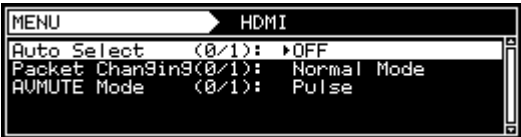
(1)	<p>Select Configuration using  →  </p> <p>or  , and then press .</p>							
(2)	<p>Select HDMI using  or  , and then press .</p>							
(3)	<p>Select Auto Select using  or  , and then press  → .</p>	<p>The values are now selected and sent automatically.</p>  <table border="1" data-bbox="853 1093 1498 1151"> <tr> <td>0</td> <td>OFF</td> <td>The optimal value is not sent.</td> </tr> <tr> <td>1</td> <td>ON</td> <td>The optimal value is sent.</td> </tr> </table>	0	OFF	The optimal value is not sent.	1	ON	The optimal value is sent.
0	OFF	The optimal value is not sent.						
1	ON	The optimal value is sent.						



































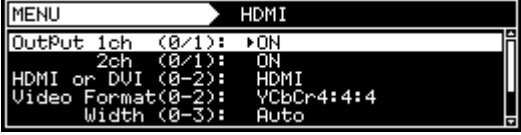

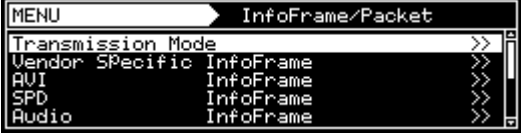

<List of automatically selected items>

- If program data has been saved when Auto Select is set to ON, the values which were set by automatic selection will be saved.
- A dash ("-") denotes that the value of the original setting is used.

Item	Setting/reference section			
AVI InfoFrame				
	AFD pattern (see "6.7 Aspect ratio patterns") now displayed			Setting other than the one given on the left
Active Format Information	Valid			-
Active Format Aspect	The setting accords with the AFD > Type setting.			-
Top Bar	Value calculated from AFD, Timing setting			-
Bottom Bar				
Left Bar				
Right Bar				
RGB or YCbCr	The setting accords with the HDMI > Video Format setting.			
Picture Aspect	The setting accords with the HDMI > AVI InfoFrame > Video Code setting. (EIA/CEA-861 standard met)			
Repetition	The setting accords with the H-Timing > Repetition setting.			
Audio InfoFrame				
	The setting accords with the Digital Audio > Source setting.			
	Ext.ANALOG to L-PCM Int.L-PCM	Ext.ANALOG to DSD	Int.DSD (Option)	Setting other than the one given on the left
	Ext.I2S L-PCM (Option)			
Sampling Frequency	-	44.1 kHz	The DSD File information is used.	-
Channel Count	The setting accords with the number of channels set to ON by Digital Audio > Output Channel .			-
	0	1	2 to 8	
	Refer StreamHeader	2ch	2 to 8ch	
ACP Packet				
	The setting accords with the ACP Packet > ACP_Type setting.			
	DVD-Audio			Setting other than the one given on the left
DVD-Audio_Type	1			0
Copy_Permission	-			0 (Copy Freely)
Copy_Number	-			0 (1 copies)
Quality	-			0
Transaction	-			0 (Not Present)
ISRC Packet				
	A The setting accords with the ACP Packet > ACP_Type setting.			
	DVD-Audio			Setting other than the one given on the left
OFF/ON ISRC1	-			OFF
ISRC2	The setting accords with the ISRC Packet > ISRC_Cont setting.			OFF
	0	1		
	OFF	-		





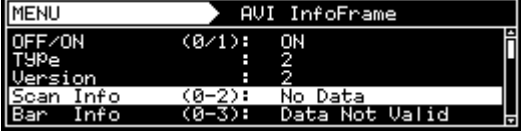







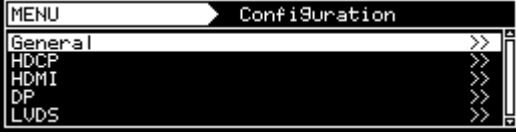

b) Setting separate InfoFrame and Packet values and sending them

This setting can be performed when “off” is selected for Auto Select in a) Sending the optimal values automatically.

(1)	<p>Select Program Edit using  →  or  INC  DEC , and then press .</p>	 <pre> MENU Program Edit Program Name : ▶EIA1920x1080P@60 Timing (TIM) >>> OutPut (TIM) >>> Audio (TIM) >>> Pattern (PAT) >>> </pre>
(2)	<p>Select Output (TIM) using  or  INC  DEC , and then press .</p>	 <pre> MENU OutPut All OutPut >>> Analog OutPut >>> Digital OutPut >>> VBI Function >>> </pre>
(3)	<p>Select Digital Output using  or  INC  DEC , and then press .</p>	 <pre> MENU Digital OutPut General >>> DUI >>> iTMS / iTMS-Quad >>> HDMI >>> DP >>> </pre>
(4)	<p>Select HDMI using  or  INC  DEC , and then press .</p>	 <pre> MENU HDMI OutPut Ich (0/1): ▶ON 2ch (0/1): ON HDMI or DUI (0-2): HDMI Video Format(0-2): YCbCr4:4:4 Width (0-3): Auto </pre>
(5)	<p>Select the Info Frame and Packet to be set. Select Info Frame/Package using  or  INC  DEC , and then press .</p>	 <pre> MENU InfoFrame/Package Transmission Mode >>> Vendor SPCific InfoFrame >>> AVI InfoFrame >>> SPD InfoFrame >>> Audio InfoFrame >>> </pre>
(6)	<p><Inputting the parameters> Select the parameters using  or  INC  DEC , and then press .</p> <p>Alternatively: Select the parameters using the number keys ( to ), and then press .</p>	<p>Example: When AVI-Info Frame is selected</p>  <pre> MENU AVI InfoFrame OFF/ON (0/1): ON Type : 2 Version : 2 Scan Info (0-2): No Data Bar Info (0-3): Data Not Valid </pre> <p>For further details on InfoFrame and Packet, refer to <InfoFrame and Packet setting parameters>.</p>





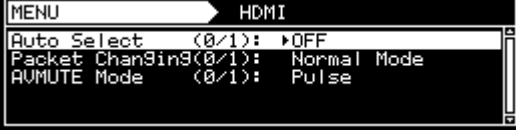















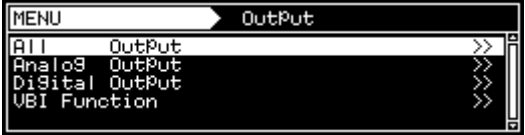









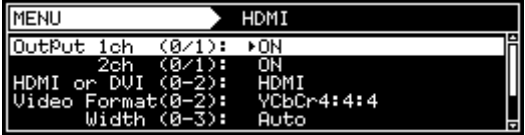



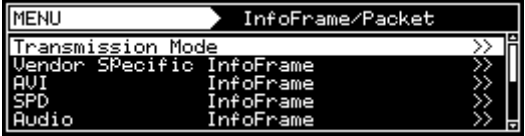

<Setting the HDMI output when making changes to InfoFrame/Packet>

When making changes to InfoFrame/Packet, users can select either to turn off the synchronization of the HDMI output or establish the settings or change only the packets without turning off the synchronization.

(1)	<p>Select Configuration using  or  , and then press .</p>							
(2)	<p>Select HDMI using  or  , and then press .</p>							
(3)	<p>Select Packet Changing using  or  , and then press .</p>	 <table border="1" data-bbox="742 784 1380 936"> <tr> <td data-bbox="742 784 774 873">0</td> <td data-bbox="774 784 949 873">Normal Mode</td> <td data-bbox="949 784 1380 873">The HDMI output synchronization is turned off, and the InfoFrame/Packet changes are made.</td> </tr> <tr> <td data-bbox="742 873 774 936">1</td> <td data-bbox="774 873 949 936">Game Mode</td> <td data-bbox="949 873 1380 936">Changes are made to Packet only (the synchronization is not turned off).</td> </tr> </table>	0	Normal Mode	The HDMI output synchronization is turned off, and the InfoFrame/Packet changes are made.	1	Game Mode	Changes are made to Packet only (the synchronization is not turned off).
0	Normal Mode	The HDMI output synchronization is turned off, and the InfoFrame/Packet changes are made.						
1	Game Mode	Changes are made to Packet only (the synchronization is not turned off).						

《 Set interval of sending InfoFrame/Packet 》

Among InfoFrame/Packet, sending interval of one kind of packet can be changed.

<p>① By using  →  or  , select Program Edit → </p>	
<p>② By using  or  , select Output (TIM) → </p>	
<p>③ By using  or  , Select Digital Output → </p>	
<p>④ By using  or  , Select HDMI → </p>	
<p>⑤ By using  or  , Select InfoFrame/Packet → </p>	
<p>⑥ By using  or  , select Transmission Mode → </p>	
<p>⑦ 《Input parameter》 By using  or  , select it →  Or 0/STATUS 9/F ↻  .  select by number keys → </p>	<p>About setting parameter, refer to the below list Transmission Mode Setting Parameter.</p>

Transmission Mode setting parameter

<p>(1) Type(0-9)</p>	<p>Select the packet to set this function.</p>
	<p>0 Vendor Specific</p>
	<p>1 AVI InfoFrame Note: it is not possible to change transmission interval of AVI InfoFrame in HDMI 300MHz unit VM-1823.</p>
	<p>2 SPD InfoFrame</p>
	<p>3 Audio InfoFrame 4 MPEG InfoFrame</p>

		5	NTSC VBI InfoFrame	
		6	ACP Packet	
		7	ISRC 1 Packet	
		8	ISRC 2 Packet	
		9	Gamut Metadata	
(2)	Interval(0-20)	Set the interval of sending packets.		
		0	Every Frame	Send every frame
		1	50ms	Send frame by the setting interval.
		2	100ms	
		:	:	
		20	1000ms	



- This setting is active when the selected packet (in “Type”)’s output setting is “ON”.
- The setting value of “Interval” is the interval of executing packet transmission that is sent from VG’s CPU to HDMI transmitter. Therefore, since the actual packet transmission is executed by HDMI transmitter, it will appear 1 or 2 frame difference from the theoretical value.

<InfoFrame and Packet setting parameters>

Listed below are the 9 InfoFrame and Packet setting parameters.

- Vendor Specific
- AVI InfoFrame
- SPD InfoFrame
- Audio InfoFrame
- MPEG InfoFrame
- NTSC VBI InfoFrame
- ACP Packet
- ISRC Packet
- Gamut Metadata Packet

CAUTION

Due to the limitations by the installed chips, the **maximum** number of packets which can be sent simultaneously is limited.

[HDMI Unit VM-1817, VM-1822]

VG can send maximum **4 packets** at a time except AVI InfoFrame and Audio InfoFrame. The packet ON/OFF check is carried out in the following sequence.

1. ACP Packet
2. ISRC1 Packet
3. ISRC2 Packet
4. Gamut Meta Data Packet
5. SPD InfoFrame
6. MPEG InfoFrame
7. Vendor Specific InfoFrame
8. NTSC VBI InfoFrame

In the example given above, Vendor Specific InfoFrame and NTSC VBI InfoFrame are disabled.

ACP Packet	: ON	SPD InfoFrame	: ON
ISRC1 Packet	: OFF	MPEG InfoFrame	: ON
ISRC2 Packet	: OFF	Vendro Specific InfoFrame	: ON
Gamut Metadata Packet	: ON	NTSC VBI InfoFrame	: ON

[VM-1823 HDMI unit for VG-873/874]

VG can send maximum **7 packets** at a time except AVI InfoFrame. However, the below packets can not be sent together.

- (1) ACP Packet and SPD InfoFrame
- (2) ISRC2 Packet and NTSC VBI InfoFrame

In case the output of combination is "ON", priority is shows below.

- (1) ACP Packet has priority to be sent.
- (2) ISRC2 Packet has priority to be sent.

■ Vendor Specific InfoFrame

The vendor specific information is stored in Vendor Specific InfoFrame, and sent.

(1)	OFF/ON	This setting determines whether Vendor Specific InfoFrame is to be sent.	
		0	OFF The Vendor Specific InfoFrame is not sent.
		1	ON The Vendor Specific InfoFrame is sent.
Listed below are the Vendor Specific InfoFrame settings. * These settings are not related to the video and audio output settings.			
(2)	Type	This is the Vendor Specific InfoFrame type setting.	
		1	* "Type" is displayed only. It cannot be changed.
(3)	Version	This is the Vendor Specific InfoFrame version setting.	
		1	* "Version" is displayed only. It cannot be changed.
(4)	IEEE RegID Sel	This selects the format setting for the IEEE Registration ID and the items after it.	
		0	Other Any IEEE Registration ID can be selected. The Payload is set after the IEEE Registration ID.
		1	HDMI The IEEE Registration ID is set to 000C03. After the IEEE Registration ID, the setting is established using the format that supports HDMI 1.4.
1. IEEE RegID Sel: Other			
1-(1)	IEEE Regist. ID	This is the IEEE Registration ID setting.	
		000000 – FFFFFFFF	
1-(2)	Payload Length	This is the Payload length setting.	
		0 – 24	
1-(3)	Payload 1-24	This is the Payload data setting.	
		00 – FF	
2. IEEE RegID Sel: HDMI			
2-(1)	IEEE Regist. ID	This indicates the IEEE Registration ID. (It cannot be changed.)	
		000C03	
2-(2)	Video Format	This is the HDMI Video Format setting.	
		0	None No additional HDMI video format is presented in this packet.
		1	Ext. Resolution Extended resolution format present.
		2	3D (Option) 3D format indication present. * '3D' is an option. The Vendor Specific InfoFrame information is not sent unless the license has been registered. For further details, contact your dealer or an ASTRODESIGN sales representative.
2-1. Video Format: Ext. Resolution			
2-1-(1)	HDMI VIC	This is the HDMI VIC setting.	
		0	4Kx2K 29.97/30 Hz
		1	4Kx2K 25 Hz
		2	4Kx2K 23.98/24 Hz
		3	4Kx2K 24 Hz (SMPTE)

2-2. Video Format: 3D (Option)			
2-2-(1)	3D Structure	this is the 3D Structure setting.	
		0 Frame Packing	
		1 Field Alternative *1	
		2 Line Alternative	
		3 Side-by-Side (Full)	
		4 L + depth	
		5 L + d + G + G-d (L + depth + graphics + graphics-depth)	
		6 Side-by-Side (Half)	
2-2-(2)	3D Ext Data	this is the 3D Ext Data setting.	
		0 Horizontal O/L,O/R *2	Horizontal sub-sampling Odd/Left picture, Odd/Right picture
		1 Horizontal O/L,E/R *2	Horizontal sub-sampling Odd/Left picture, Even/Right picture
		2 Horizontal E/L,O/R *2	Horizontal sub-sampling Even/Left picture, Odd/Right picture
		3 Horizontal E/L,E/R *2	Horizontal sub-sampling Even/Left picture, Even/Right picture
		4 Quincunx O/L,O/R	Quincunx matrix Odd/Left picture, Odd/Right picture
		5 Quincunx O/L,E/R	Quincunx matrix Odd/Left picture, Even/Right picture
		6 Quincunx E/L,O/R	Quincunx matrix Even/Left picture, Odd/Right picture
		7 Quincunx E/L,E/R	Quincunx matrix Even/Left picture, Even/Right picture
2-2-(3)	3D Meta Present	this is the 3D Meta present (whether the following 3D metadata is present or not) setting.	
		0 0 (Not Present)	3D metadata not present
		1 1	3D metadata present
2-2-(4)	Metadata Type	this indicates the 3D Metadata type. (it cannot be changed.) 0	
2-2-(5)	Metadata Length	this is the 3D Metadata Length setting. 0 – 21 *3	
2-2-(6)	Metadata 1-21 *3	this is the 3D Metadata data setting.	
		00 – FF	



***1:**
The output signals differ from the ones in the standards. The DE signal is high for three Vblank periods of the current Field Alternative.



***2:**
The 3D Ext Data values of 0 to 3 have all been made consistent with “Horizontal sub-sampling” in HDMI Ver.1.4a standard. With this generator, the old expressions are used to differentiate the drawing method used with optional pattern 101 and to provide compatibility.



*3

If the setting value of 3D Structure is “Side-by-site (Half)”, the maximum data of 3D Metadata is 20 bytes.

If you set “21” in Metadata Length, the last data (21st byte) is not sent.

Please refer to the below list.

Packet Byte#	7	6	5	4	3	2	1	0
PB 0	Checksum							
PB 1	24bit IEEE Registration Identifier (000C03h) (least significant byte first)							
PB 2								
PB 3								
PB 4	HDMI_Video_Format (010b(3D))			Rsvd (0)	Rsvd (0)	Rsvd (0)	Rsvd (0)	Rsvd (0)
PB 5	3D_Structure				3D_Metadata_Present	Rsvd (0)	Rsvd (0)	Rsvd (0)
PB 6	3D_Metadata_Type			3D_Metadata_Length				
PB 7	3D_Metadata_1							
PB 8	3D_Metadata_2							
PB 9	3D_Metadata_3							
:	:							
PB 26	3D_Metadata_20							
PB 27	3D_Metadata_21							

例1: 3D_Structureの設定が『Side-by-Side(Half)』以外の場合のパケットデータマッピング

Example 1: Packet data mapping except Side-by-Side(Half).

Packet Byte#	7	6	5	4	3	2	1	0
PB 0	Checksum							
PB 1	24bit IEEE Registration Identifier (000C03h) (least significant byte first)							
PB 2								
PB 3								
PB 4	HDMI_Video_Format (010b(3D))			Rsvd (0)	Rsvd (0)	Rsvd (0)	Rsvd (0)	Rsvd (0)
PB 5	3D_Structure (1000b(Side-by-Side(Half)))				3D_Metadata_Present	Rsvd (0)	Rsvd (0)	Rsvd (0)
PB 6	3D_Ext_Data				Reserved (0)			
PB 7	3D_Metadata_Type			3D_Metadata_Length				
PB 8	3D_Metadata_1							
PB 9	3D_Metadata_2							
PB 10	3D_Metadata_3							
:	:							
PB 26	3D_Metadata_19							
PB 27	3D_Metadata_20							

Example 2: Packet data mapping of Side-by-Side(Half).

■ AVI InfoFrame

“AVI InfoFrame” stands for Auxiliary Video Information InfoFrame. The information (including the color space and aspect ratio) of the transmission images is stored in it, and sent.

Note: HDMI 300MHz unit (VM-1823) always send AVI InfoFrame while HDMI is output.

(1)	OFF/ON	This setting determines whether the AVI InfoFrame is to be sent.	
		0	OFF The AVI InfoFrame is not sent. Note: it is not available in VM-1823.
		1	ON The AVI InfoFrame is sent.
Listed below are the AVI InfoFrame settings. * These settings are not related to the video and audio output settings.			
(2)	Type	This is the AVI InfoFrame type setting.	
		2	* “Type” is displayed only. It cannot be changed.
(3)	Version	This is the AVI InfoFrame version setting.	
		1	Version 1
		2	Version 2
(4)	Scan Info	This sets the Scan Information. (It sets whether processing is required for the transmitted images.)	
		0	No Data No Data
		1	Overscanned Composed for an overscanned display.
		2	Underscanned Composed for an underscanned display.
(5)	Bar Info	This sets the Bar Info (valid/invalid for the Bar Information described later).	
		0	Data Not Valid Bar Data not valid
		1	Vertical Valid Vert.Bar info valid
		2	Horizontal Valid Horiz.Bar info Valid
		3	Vert. & Horiz. Valid Vert. And Horiz. Bar Info valid
(6)	ActiveF Info	This is the Active Format Information Present setting (valid/invalid for the Active Format Aspect Ratio described later).	
		0	No Data No Data
		1	Valid Active Format Information Valid
(7)	RGB or YCbCr	This is the RGB or YCbCr (color space of transmitted images) setting.	
		0	RGB
		1	YCbCr 4:2:2
		2	YCbCr 4:4:4
(8)	ActiveF Aspect	This is the Active Format Aspect Ratio (aspect ratio of the video parts (excluding Bar of letter box, etc.)) setting.	
		0	Same Picture
		1	4:3 (center)
		2	16:9 (center)
		3	14:9 (center)
		4	Box 16:9 (top)
		5	Box 14:9 (top)
		6	Box > 16:9 (center)
		7	4:3 (14:9 center)
		8	16:9 (14:9 center)
		9	16:9 (4:3 center)

(9)	Picture Aspect	This is the Picture Aspect Ratio (aspect ratio of the video parts including Bar of letter box, etc.) setting.	
		0	No Data No Data
		1	4:3 4:3
		2	16:9 16:9
(10)	Scaling	This is the Non-Uniform Picture Scaling (direction in which transmitted images have been scaled) setting.	
		0	No Known No Known non-uniform Scaling
		1	Horizontal Picture has been scaled horizontally
		2	Vertical Picture has been scaled vertically
		3	Horiz. & Vert. Picture has been scaled horizontally and vertically
(11)	Colorimetry	This is the Colorimetry (the standard whose coefficients were used for conversion into color difference signals) setting.	
		0	No Data No Data
		1	SMPTE170M ITU601 SMPTE170M/ITU601
		2	ITU709 ITU709
		3	Extended Valid Extended Colorimetry Information Valid
(12)	Video Code	This is the Video Format Identification Code setting.	
		0 - 64	For further details on the timings indicated by Code, refer to CEA-861-D.
(13)	Repetition	1 - 10	This is the Pixel Repetition Factor setting.
(14)	Top Bar	0 - 65535	This is the Line Number of End of Top Bar setting (letter box top bar size setting).
(15)	Bottom Bar	0 - 65535	This is the Line Number of Start of Bottom Bar setting (letter box bottom bar size setting).
(16)	Left Bar	0 - 65535	This is the Pixel Number of End of Left Bar setting (pillar box left bar size setting).
(17)	Right Bar	0 - 65535	This is the Pixel Number of Start of Right Bar setting (pillar box right bar size setting).
(18)	RGB Quan.Range	This is the RGB Quantization Range setting (quantization range when RGB images apply for Colorimetry).	
		0	Default
		1	Limited Range
		2	Full Range
(19)	YCC Quan.Range	This is the YCC Quantization Range setting (quantization range when YCC images apply for Colorimetry).	
		0	Limited Range
		1	Full Range
(20)	Extended Colo.	This is the Extended Colorimetry setting. (This is referenced when Extended Valid has been set as the Colorimetry setting.)	
		0	XvYCC601
		1	XvYCC709
		2	sYCC601
		3	AdobeYCC601
		4	AdobeRGB

(21)	IT content	This is the IT Content (whether the transmitted images are IT content) setting.			
		0	No data		
		1	IT Content		
(22)	IT content Type	This is the IT Content Type setting.			
		0	Graphics		
		1	Photo		
		2	Cinema		
		3	Game		
(23)	Checksum	This is the checksum setting.		*1	
		0	Auto		The value is calculated automatically.
		1	Manual		The desired value is set.
			00h - 0FFh		
(24)	Length	0 - 15 [byte]	This is the AVI InfoFrame length setting. (Packet Header and Checksum are not included.) The default is 13 bytes. Note: it is not available in VM-1823.		
(25)	Data Byte 14, 15	00h - 0FFh	This is the data byte 14 and 15 value setting. Note: it is not available in VM-1823.		

*1: The Checksum, Length and Data byte 14,15 settings are optional. They can be set only when the requisite license has been registered. When it has not been registered, the Checksum setting is fixed at Auto and the Length setting at 13 bytes.

■ SPD InfoFrame

“SPD InfoFrame” stands for Source Product Description InfoFrame. The information of the transmission device is stored in it, and sent.

(1)	OFF/ON	This setting determines whether the SPD InfoFrame is to be sent.	
		0	OFF The SPD InfoFrame is not sent.
		1	ON The SPD InfoFrame is sent.
Listed below are the SPD InfoFrame settings. * These settings are not related to the video and audio output settings.			
(2)	Type	This is the SPD InfoFrame type setting.	
		3	* “Type” is displayed only. It cannot be changed.
(3)	Version	This is the SPD InfoFrame version setting.	
		1	Version1 * “Version” is displayed only. It cannot be changed.
(4)	Vendor Name	This is the Vendor Name (name of the transmission device vendor) setting.	
		Maximum 8 characters	For further details on the input method, refer to steps (2) and following in section “2.3 Setting the names”
(5)	Product Description	This the Product Description (name of the transmission device (model name, etc.)) setting.	
		Maximum 16 characters	For further details on the input method, refer to steps (2) and following in section “2.3 Setting the names”
(6)	Source Device	This is the Source Device Information (the type of transmission device) setting.	
		0	Unknown
		1	Digital STB
		2	DVD Player
		3	D-VHS
		4	HDD Video recorder
		5	DVC
		6	DSC
		7	Video CD
		8	Game
		9	PC general
		A	Blue-Ray Disc
		B	Super Audio CD
C	HD DVD		
D	PMP		

■ Audio InfoFrame

The transmission audio information is stored in the Audio InfoFrame, and sent.

(1)	OFF/ON	This setting determines whether the Audio InfoFrame is to be sent.	
		0	OFF The Audio InfoFrame is not sent.
		1	ON The Audio InfoFrame is sent.
Listed below are the Audio InfoFrame settings. * These settings are not related to the video and audio output settings.			
(2)	Type	This is the AVI Audio InfoFrame type setting.	
		4	* "Type" is displayed only. It cannot be changed.
(3)	Version	This is the Audio InfoFrame version setting.	
		1	* "Version" is displayed only. It cannot be changed.
(4)	Coding Type	This is the Audio Coding Type setting.	
		0	Refer StreamHeader Refer to Stream Header
		1	IEC60958 PCM
		2	AC-3
		3	MPEG1 (Layers 1&2)
		4	MP3 (MPEG1 Layer 3)
		5	MPEG2 (multi ch.)
		6	AAC
		7	DTS
		8	ATRAC
		9	One Bit Audio
		A	Dolby Digital +
		B	DTS-HD
		C	MLP
D	DST		
E	WMA Pro		
F	Refer Extension		
(5)	Coding Ext Type	This is the Audio Coding Ext Type setting.	
		0	HE-AAC
		1	HE-AACv2
		2	MPEG Surround
(6)	Channel Count	This is the Audio Channel Count setting.	
		0	Refer StreamHeader Refer to Stream Header
		1	2 ch
		↓	↓
		7	8 ch
(7)	Sampling Freq	This is the Sampling Frequency setting.	
		0	Refer StreamHeader Refer to Stream Header
		1	32 kHz
		2	44.1 kHz
		3	48 kHz
		4	88.2 kHz
		5	96 kHz
		6	176.4 kHz
		7	192 kHz

(8)	Sample Size	This is the Sample Size setting.								
		0	Refer StreamHeader	Refer to Stream Header						
		1	16 bit							
		2	20 bit							
		3	24 bit							
(9)	Speaker Placement	This is the Channel/Speaker Allocation setting.								
			8ch	7ch	6ch	5ch	4ch	3ch	2ch	1ch
		0		-	-	-	-	-	FR	FL
		1		-	-	-	-	LFE	FR	FL
		2		-	-	-	FC	-	FR	FL
		3		-	-	-	FC	LFE	FR	FL
		4		-	-	RC	-	-	FR	FL
		5		-	-	RC	-	LFE	FR	FL
		6		-	-	RC	FC	-	FR	FL
		7		-	-	RC	FC	LFE	FR	FL
		8		-	RR	RL	-	-	FR	FL
		9		-	RR	RL	-	LFE	FR	FL
		10		-	RR	RL	FC	-	FR	FL
		11		-	RR	RL	FC	LFE	FR	FL
		12		RC	RR	RL	-	-	FR	FL
		13		RC	RR	RL	-	LFE	FR	FL
		14		RC	RR	RL	FC	-	FR	FL
		15		RC	RR	RL	FC	LFE	FR	FL
		16	RRC	RLC	RR	RL	-	-	FR	FL
		17	RRC	RLC	RR	RL	-	LFE	FR	FL
		18	RRC	RLC	RR	RL	FC	-	FR	FL
		19	RRC	RLC	RR	RL	FC	LFE	FR	FL
		20	FRC	FLC	-	-	-	-	FR	FL
		21	FRC	FLC	-	-	-	LFE	FR	FL
		22	FRC	FLC	-	-	FC	-	FR	FL
		23	FRC	FLC	-	-	FC	LFE	FR	FL
		24	FRC	FLC	-	RC	-	-	FR	FL
		25	FRC	FLC	-	RC	-	LFE	FR	FL
		26	FRC	FLC	-	RC	FC	-	FR	FL
		27	FRC	FLC	-	RC	FC	LFE	FR	FL
		28	FRC	FLC	RR	RL	-	-	FR	FL
		29	FRC	FLC	RR	RL	-	LFE	FR	FL
		30	FRC	FLC	RR	RL	FC	-	FR	FL
31	FRC	FLC	RR	RL	FC	LFE	FR	FL		
(10)	Level Shift Value	This is the Level Shift Value setting.								
		0 - 15	The decibel (dB) level is set here.							
(11)	Down-mix	This is the Down -mix Inhibit Flag setting.								
		0	Permitted / No Info	Permitted or no information about any assertion of this						
		1	Prohibited	Prohibited						

(12)	LEF PB Level	This is the LEF Playback Level setting.	
		0	Unknown
		1	0 dB Playback
		2	+10 dB Playback

■ MPEG InfoFrame

If the original source of the data prior to its conversion to HDMI is MPEG data, its information is stored in MPEG InfoFrame, and sent.

(1)	OFF/ON	This setting determines whether the MPEG InfoFrame is to be sent.	
		0	OFF The MPEG InfoFrame is not sent.
		1	ON The MPEG InfoFrame is sent.
Listed below are the MPEG InfoFrame settings. * These settings are not related to the video and audio output settings.			
(2)	Type	This is the MPEG InfoFrame type setting.	
		5	* "Type" is displayed only. It cannot be changed.
(3)	Version	This is the MPEG InfoFrame version setting.	
		1	* "Version" is displayed only. It cannot be changed.
(4)	Bit Rate	0 - 4294 M 967 k 295 Hz	This is the MPEG bit rate setting.
(5)	Field Repeat	This is the Field Repeat setting.	
		0	New Field(picture)
		1	Repeated Field
(6)	Frame	This is the MPEG Frame setting.	
		0	Unknown(No Data)
		1	I Picture
		2	B Picture
		3	P Picture

■ NTSC VBI InfoFrame

The vertical blanking interval (VBI) information is stored in NTSC VBI InfoFrame, and sent.

(1)	OFF/ON	This setting determines whether the NTSC VBI InfoFrame is to be sent.	
		0	OFF The NTSC VBI InfoFrame is not sent.
		1	ON The NTSC VBI InfoFrame is sent.
Listed below are the NTSC VBI InfoFrame settings. * These settings are not related to the video and audio output settings.			
(2)	Type	This is the NTSC VBI InfoFrame type setting.	
		6	* "Type" is displayed only. It cannot be changed.
(3)	Version	This is the NTSC VBI InfoFrame version setting.	
		1	* "Version" is displayed only. It cannot be changed.
(4)	PES Length	0 - 27	This sets the PES length.
(5)	PES 1-5/6-10/11-15/16-20/ 21-25/26-27	00 - FF	This sets the PES data.

■ ACP Packet

“ACP Packet” stands for Audio Content Protection Packet. The copyright protection information added to DVD-Audio and Super Audio CD contents is stored in it, and sent.

(1)	OFF/ON	This setting determines whether the ACP Packet is to be sent.			
		0	OFF	The ACP Packet is not sent.	
		1	ON	The ACP Packet is sent.	
Listed below are the ACP Packet settings.					
* These settings are not related to the video and audio output settings.					
(2)	ACP_Type	This is the ACP Type setting.			
		0	Generic Audio		
		1	IEC60958 Audio		
		2	DVD-Audio		
		3	Super Audio CD		
(3)	DVD-Audio Type	This is the DVD-Audio_Type_Dependent_Generation setting.			
		0	* This must be set to 1 when “DVD-Audio” has been selected as the ACP_Type setting.		
		1			
(4)	CopyPermission	Audio_Copy_permission (the information concerning the permission to copy DVD-Audio content) is set here.			
		0	Copy Freely		
		1	(reserved)		
		2	Specify CopyNumber		
		3	No More Copies		
(5)	Copy_Number	Audio_copy_number (the number of times DVD-Audio content may be copied) is set here.			
		0	1 copies		
		1	2 copies		
		2	4 copies		
		3	6 copies		
		4	8 copies		
		5	10 copies		
		6	3 copies		
		7	Copy OneGeneration		
(6)	Quality	Audio_Quality (the quality in which DVD-Audio content is to be copied) is set here.			
			No. of channels	Sampling frequency	Bit width
		0	2 channels or less	Lower than 48 kHz	16 bits or less
		1	2 channels or less	No restrictions	No restrictions
		2	No restrictions	No restrictions	No restrictions
		3	No restrictions	Lower than 48 kHz	16 bits or less
(7)	Transaction	Audio_Transaction (whether the status of optional access control is contained in the DVD-Audio data) is set here.			
		0	Not Present	not present	
		1	(reserved)	Reserved for copyright management system use	

(8)	Count_A	Count_A (the number of times the Super Audio CD contents can be copied by an approved secure recorder) is set here.	
		0	Prohibited
		1 - 254	Allowed from 1 to 254 times
		255	No restrictions
(9)	Count_S	Count_S (the number of times the Super Audio CD contents can be copied by a secure recorder) is set here.	
		0	Prohibited
		1 - 254	Allowed from 1 to 254 times
		255	No restrictions
(10)	Count_U	Count_U (the number of times the Super Audio CD contents can be copied by an unlisted recorder) is set here.	
		0	Prohibited
		1 - 254	Allowed from 1 to 254 times
		255	No restrictions
(11)	CCI_Flags_Q_A	CCI_Flags_Q_A (the quality in which Super Audio content is to be copied by an approved secure recorder) is set here.	
		0	CD Quality
		1	Unlimited DSD Quality
(12)	CCI_Flags_Q_S	CCI_Flags_Q_S (the quality in which Super Audio content is to be copied by a secure recorder) is set here.	
		0	CD Quality
		1	Unlimited DSD Quality
(13)	CCI_Flags_Q_U	CCI_Flags_Q_U (the quality in which Super Audio content is to be copied by an unlisted recorder) is set here.	
		0	CD Quality
		1	Unlimited DSD Quality
(14)	CCI_Flags_Move_A	CCI_Flags_Move_A (whether copying of Super Audio content by individual track onto an approved secure recorder is allowed) is set here.	
		0	Not Allowed
		1	Allowed
(15)	CCI_Flags_Move_S	CCI_Flags_Move_S (whether copying of Super Audio content by individual track onto a secure recorder is allowed) is set here.	
		0	Not Allowed
		1	Allowed
(16)	CCI_Flags_Move_U	CCI_Flags_Move_U (whether copying of Super Audio content by individual track onto an unlisted recorder is allowed) is set here.	
		0	Not Allowed
		1	Allowed

■ ISRC Packet

“ISRC Packet” stands for International Standard Recording Code Packet. The sound source identification codes and other information are stored in it, and sent.

(1)	OFF/ON ISRC1	Whether to send the ISRC1 Packet is set here.	
		0	OFF The ISRC1 Packet is not sent.
		1	ON The ISRC1 Packet is sent.
(2)	OFF/ON ISRC2	Whether to send the ISRC2 Packet is set here.	
		0	OFF The ISRC2 Packet is not sent.
		1	ON The ISRC2 Packet is sent.
Listed below are the ISRC Packet settings. * These settings are not related to the video and audio output settings.			
(3)	ISRC_Cont	This is the ISRC Continued setting.	
		0	ISRC2 is not sent.
		1	ISRC2 is sent.
(4)	ISRC_Valid	This is the ISRC Valid setting. (ISRC Valid indicates whether data has been set to the ISRC_Status in the ISRC Packet and whether the UPC_EAN_ISRC_XX field is valid.)	
		0	Invalid
		1	Valid
(5)	ISRC_Status	This is the ISRC_Status setting. (ISRC_Status indicates the position on the current track.)	
		0	Starting
		1	Intermediate
		2	Ending
(6)	Validity Info	This is the Validity information setting. (This indicates whether the ISRC and UPC/EAN data is valid or invalid.)	
		0	No Validity
		1	ISRC
		2	UPC/EAN
		3	UPC/EAN and ISRC
(7)	Catalogue Code	This is the Catalogue Code (UPC/EAN #1 - 13) setting. Number consisting of 13 digits	
(8)	Country Code	This is the Country Code (ISRC #1 - 2) setting. Character string consisting of 2 letters	
(9)	First Owner Code	This is the First Owner Code (ISRC #3 - 5) setting. Character string consisting of 3 alphanumeric	
(10)	Year of Rec. Code	This is the Year-of-recording code (ISRC #6 - 7) setting. Number consisting of 2 digits	
(11)	Recording-item Code	This is the Recording code / Recording-item code (ISRC #8 -12) setting. Number consisting of 5 digits	

■ Gamut Metadata Packet

If the transmission images have been sent by xvYCC, their color space information (range, etc.) is stored in the Gamut Metadata Packet, and sent.

(1)	OFF/ON	This setting determines whether the Gamut Metadata Packet is to be sent.	
		0	OFF The Gamut Metadata Packet is not sent.
		1	ON The Gamut Metadata Packet is sent.
Listed below are the Gamut Metadata Packet settings. * These settings are not related to the video and audio output settings.			
(2)	Next-Field	This is the Next_Field setting. (This indicates whether GBD (Gamut Boundary Description) sent in this Gamut Metadata Packet is applicable to the next video field.)	
		0	Not applicable
		1	Applicable
(3)	No_Current_GBD	This is the No_Current_GBD setting. (This indicates whether GBD sent in this Gamut Metadata Packet is valid or invalid.)	
		0	Invalid
		1	Valid
(4)	GBD_Profile	This is the GBD_Profile setting.	
		0	P0
		1	P1
		2	P2
		3	P3
(5)	AffectedGamutSeqNum	0 - 15	This is the Affected_Gamut_Seq_Num setting. (This indicates the number of GBD (Gamut boundary description) sent in this Gamut Metadata Packet.)
(6)	Current_GamutSeqNum	0 - 15	This is the Current_Gamut_Seq_Num setting. (This indicates the number of the GBD that applies to the current video field.)
(7)	Packet_Seq	This is the Packet_Seq setting. (This identifies what this Gamut Metadata Packet is in the Gamut Metadata Packet Sequence.)	
		0	Intermediate Intermediate packet in sequence
		1	First First packet in sequence
		2	Last Last packet in sequence
		3	Only Only packet in sequence
(8)	Format_Flag	This is the Format_Flag setting. (This indicates the format of the GBD sent.)	
		0	Vertices/Facets Vertices/Facets description
		1	Range Range description
(9)	Colorprecision	This is the GBD_Color_Precision setting. (This indicates the precision (bit width) of the vertex and range data in GBD.)	
		0	8 bit
		1	10 bit
		2	12 bit

(10)	Color_Space	This is the GBD_Color_Space setting.		
		■ When Vertices/facets (0) has been selected as the Format_Flag setting		
		0	ITU-R BT.709	ITU-R BT.709 (using RGB)
		1	xvYCC601	xvYCC601 (IEC61966-2-4-SD) (using YCbCr)
		2	xvYCC709	xvYCC709 (IEC61966-2-4-HD) (using YCbCr)
		3	XYZ	XYZ
		■ When Range (1) has been selected as the Format_Flag setting		
		0	Reserved	Reserved
		1	xvYCC601	RGB expression of xvYCC601 coordinates
		2	xvYCC709	RGB expression of xvYCC709 coordinates
3	Reserved	Reserved		
(11)	Number_Vertices	This is the Number_Vertices setting.		
		* This is displayed only when Vertices/facets (0) has been selected as the Format_Flag setting.		
		Colorprecision =		
		8 bit: 4 - 8		
		10 bit: 4 - 6		
		12 bit: 4 - 5		
(12)	Packed_GBD_Vertices_Data	This is the Packed_GBD_Vertices_Data setting.		
		* This is displayed only when Vertices/facets (0) has been selected as the Format_Flag setting.		
		Data1	Colorprecision =	The Y, Cb and Cr values of the colors (Data) are set here.
		Data2	8 bit: 0 - 255	
		Data3	10 bit: 0 - 1023	
Data4	12 bit: 0 - 4095			
(13)	Packed_Range_Data	This is the Packed_Range_Data setting.		
		* This is displayed only when Range (1) has been selected as the Format_Flag setting.		
		Min_Red	Colorprecision =	The Range Data of the colors (Red, Green and Blue) are set here.
		Max_Red	8 bit: -3.96875 - +3.96875	
		Min_Green	10 bit: -3.9921875 - +3.9921875	
		Max_Green	12 bit: -3.998046875 - +3.998046875	
		Min_Blue		
Max_Blue				

4.2.4 CEC function

HDMI can send and receive the CEC commands, and display them on the screen. The CEC function has three operation modes.

a) Monitor mode (Monitor)

In this mode, the sending and receiving of the commands generated between the equipment connected to CEC are displayed on the screen.

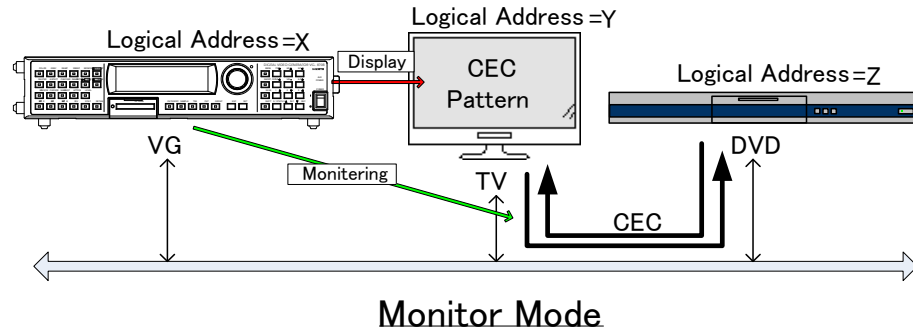

b) Transmission mode (Transmission)

In this mode, the commands are sent from the generator to the designated logical address.

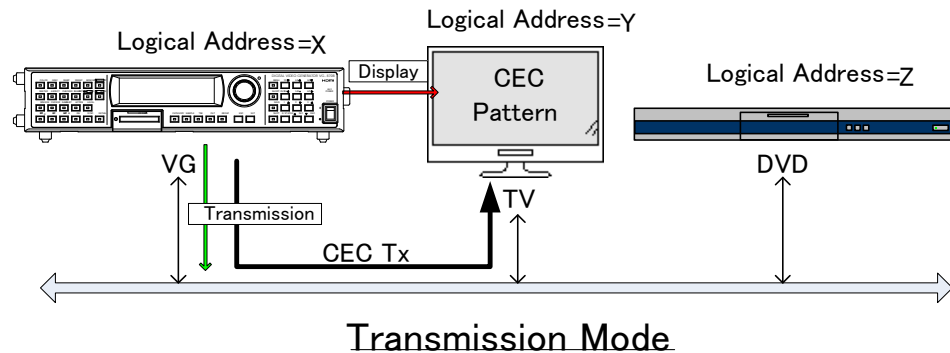





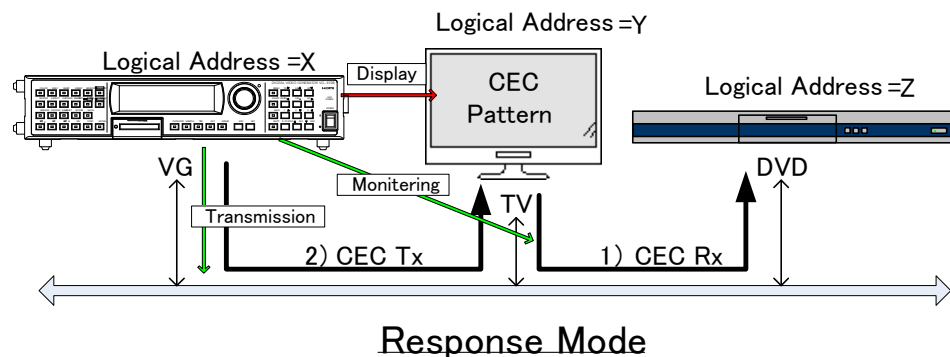



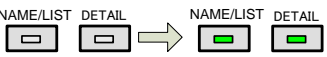

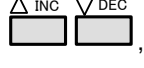
c) Response mode (Response)

In this mode, the commands are sent as responses when the designated commands have been transmitted.

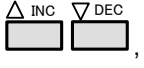

<CEC display procedure>

<p>(1) NAME/LIST DETAIL → NAME/LIST DETAIL</p> 	
<p>(2) <Selecting the CEC></p> <p>Select the CEC using  or , and then press .</p>	
<p>(3) <Detailed setting: Selecting EDIT></p> <p>Select EDIT using  or , and then press .</p> <p>Alternatively, select EDIT using .</p> <p>After the setting items have been edited, select EXECUTE, and press the SET key to enable the settings.</p>	

<Table of CEC setting items>

(1)	VG Logical Address	This sets the logical address of the VG generator. (0 to F)		
(2)	Port (0-1)	This sets the port used for CEC execution.		
		0	HDMI1	CEC is executed using HDMI1.
		1	HDMI2	CEC is executed using HDMI2.
(3)	Mode (0-2)	This sets the operation mode.		
		0	Monitor	The CEC commands are monitored.
		1	Transmission	The CEC commands set using items (4) to (7) are transmitted.
		2	Response	When commands have been received under conditions (8) to (12), the CEC commands set using items (4) to (7) are transmitted.
Set here the CEC commands to be sent from the VG-870B/871B/873/874.				
The following items are set when Transmission or Response has been selected as the Mode setting .				
(4)	Tx Destination	-	This sets the address of the destination (transmission destination of CEC commands).	
(5)	Tx Opcode	-	This sets the OPCode.	
(6)	Tx Data Length	0 to 14	This sets the length of the Tx data .	
(7)	Tx Data [H] 1-6/7-12/13-14	-	This sets the CEC command data.	
Set here the CEC commands to be received from the VG-870B/871B/873/874.				
The following items are set when Response has been selected as the Mode setting .				
(8)	Rx Initiator	0 to E	This sets the address of the initiator.	
(9)	Rx Destination	0 to F	This sets the address of the destination . This can also be set using a logical address other than the one set using item (1).	
(10)	Rx Opcode	-	This sets the OPCode.	
(11)	Rx Data Length	0 to 14	This sets the length of the Rx data .	
(12)	Rx Data [H] 1-6/7-12/13-14	-	This sets the CEC command data.	

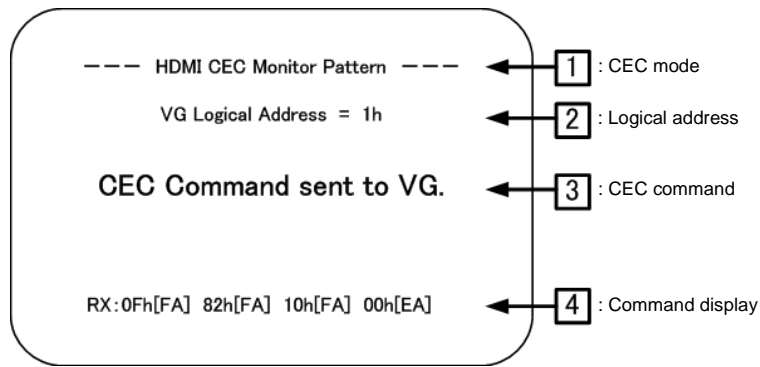

(1)	CEC mode	<p>“HDMI CEC Monitor Pattern”: Monitor mode</p> <p>“HDMI CEC Transmission Pattern”: Command transmission mode</p> <p>“HDMI CEC Response Pattern”: Command response mode</p>
(2)	Logical Address	VG logical address which has been set
(3)	Display of CEC command transmission/reception status	<p>“CEC Command send to Device Xh” : The command has been transmitted to the unit (Destination Logical Address Xh) which has been set.</p> <p>“CEC Command sent to VG” : The generator has received a command. (Command destined to the VG logical address which has been set.)</p> <p>“CEC Command sent to Other Devices” : A command has been transferred to a unit other than the generator. (A command to a VG logical address other than the one which has been set)</p> <p>“Waiting Command ...” : Command wait status (which is established when a command is not transmitted or received for 5 or more seconds)</p>
(4)	Command display	<p>When the corresponding command has been transmitted or received, it is displayed.</p> <div style="border: 1px solid black; padding: 5px; margin: 10px auto; width: fit-content;"> <p>XXh[FA] XXh[FA] XXh[FA] XXh[EA]</p> </div> <ul style="list-style-type: none"> ┌ Acknowledge └ A: Provided └ N: Not provided ┌ End of Message └ E: Yes └ F: No ┌ Data portion <p>TX is a command which is transmitted by the generator; RX is a command which is received by the generator.</p> <p>* Commands sent to the destination address of Fh are judged to be broadcast messages and indicated using the polarity which is the reverse of regular ACK polarity.</p>

4.2.5 Embedded audio, high bit rate audio (option)





















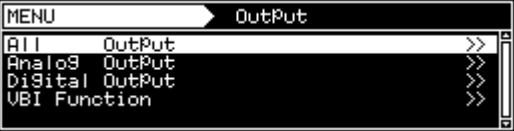







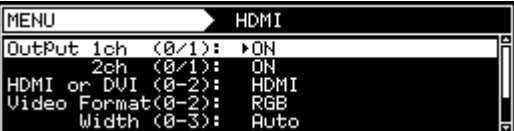

HDMI enables embedded audio and high bit rate audio to be output.

High bit rate audio is treated as an option. Contact your dealer or an ASTRODESIGN sales representative.

The operating procedure is as follows:

- a) Enable the embedded audio to be superimposed on HDMI.
- b) Set the sound source, frequency, level, etc.

a) Enable the embedded audio to be superimposed on HDMI.

<p>(1) Select Program Edit using    or  INC  DEC, and then press .</p>	 <pre> MENU Program Edit Program Name : ▶EIA1920x1080P@60 Timing (TIM) >>> Output (TIM) >>> Audio (TIM) >>> Pattern (PAT) >>> </pre>						
<p>(2) Select Output (TIM) using  or  INC  DEC, and then press .</p>	 <pre> MENU OutPut All OutPut >>> Analog OutPut >>> Digital OutPut >>> VBI Function >>> </pre>						
<p>(3) Select Digital Output using  or  INC  DEC, and then press .</p>	 <pre> MENU Digital OutPut General >>> DUI >>> iTMS / iTMS-Quad >>> HDMI >>> DP >>> </pre>						
<p>(4) Select HDMI using  or  INC  DEC, and then press .</p>	 <pre> MENU HDMI OutPut 1ch (0/1): ▶ON 2ch (0/1): ON HDMI or DUI (0-2): HDMI Video Format(0-2): RGB Width (0-3): Auto </pre>						
<p>(5) Select Audio Output using  or  INC  DEC, and then press .</p> <p>Select the setting using  or  INC  DEC, and then press  or select .</p>	 <pre> MENU HDMI HDMI or DUI (0-2): HDMI Video Format(0-2): RGB Width (0-3): Auto Audio OutPut(0/1): ▶ON InfoFrame/Package >>> </pre> <table border="1" data-bbox="748 1406 1374 1503"> <tbody> <tr> <td>0</td> <td>OFF</td> <td>Disabled</td> </tr> <tr> <td>1</td> <td>On</td> <td>Enabled</td> </tr> </tbody> </table>	0	OFF	Disabled	1	On	Enabled
0	OFF	Disabled					
1	On	Enabled					

b) Setting the sound source, frequency, level, etc.

For further details on the setting procedure, refer to "4.16 Digital audio."

4.2.6 EDID

For further details on the setting procedure, refer to “6.13.3 EDID.”

4.2.7 HDCP

For further details on the setting procedure, refer to “8.1 HDCP settings.”

4.2.8 DDC/CI

For further details on the setting procedure, refer to “6.13.4 DDC/CI.”

4.2.9 LipSync

For further details on the setting procedure, refer to “7.9 LipSync.”

4.2.10 VD-1673 (HDMI SWITCHER)

















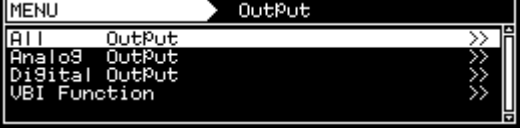







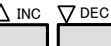

The VD-1673 is an HDMI switcher (with 2 inputs and 8 outputs) made by ASTRODESIGN.

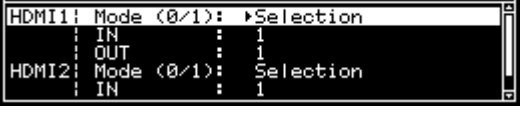
The settings described in this section take effect only when the VD-1673 is connected to the generator and the "mode in which control is exercised by the VG series" has been selected.

* **Be absolutely sure to connect the VD-1673 before turning on the power of the generator.**

For further details on the settings, refer to the operating instructions of the VD-1673.

<Setting procedure>

(1)	Select Program Edit using  or  , and then press  .	 <pre> MENU Program Edit Program Name : ▶EIA1920x1080P@60 Timing < TIM > Output < TIM > Audio < TIM > Pattern < PAT > </pre>
(2)	Select Output (TIM) using  or  , and then press  .	 <pre> MENU OutPut All OutPut Analog OutPut Digital OutPut VBI Function </pre>
(3)	Select Digital Output using  or  , and then press  .	 <pre> MENU Digital OutPut General DUI iTMS / iTMS-Quad HDMI DP </pre>
(4)	Select HDMI using  or  , and then press  .	 <pre> MENU HDMI OutPut 1ch <0/1>: ▶ON 2ch <0/1>: ON HDMI or DUI <0-2>: HDMI Video Format<0-2>: YCbCr4:4:4 Width <0-3>: Auto </pre>
(5)	Select VD-1673 (HDMI SWITCHER) using  or  , and then press  .	 <pre> MENU VD-1673(HDMI SWITCHER) HDMI1: Mode <0/1>: ▶Selection IN : 1 OUT : 1 HDMI2: Mode <0/1>: Selection IN : 1 </pre>
(6)	<Inputting the parameters> Select the parameters using  or  , and then press  . Alternatively: Select the parameters using the number keys  ( to ), and then press  .	

<Table of setting items>

The items are set for each of the HDMI1 and HDMI2 output channels.

(1)	Mode (0/1)	The output mode is selected here. 0 Selection Selection mode 1 Distribution Distribution mode
(2)	IN	The input port is selected here. Setting range: 1 to 2
(3)	OUT	The output port is selected here. Setting range: 1 to 8













4.2.11 Audio Return Channel

On this screen, the Audio Return Channel function is executed, and the patterns of the related data are displayed.

The sound received is output from the COAX digital audio output connector.

* This function is supported only by the HDMI 1.4a unit (VM-1822) and HDMI 300MHz unit (VM-1823). It is not supported by the VM-1817 HDMI Unit.

<Audio Return Channel display procedure>

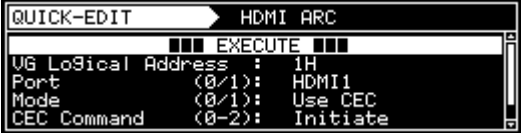
<p>(1)</p> 	
<p>(2) <Selecting the HDMI ARC></p> <p>Select the HDMI ARC using  or  .</p> <p> DEC .</p>	
<p>(3) <Detailed setting: Selecting EDIT></p> <p>Select EDIT using  or  , and then press .</p> <p>Alternatively, select EDIT using .</p> <p>After the setting items have been edited, select EXECUTE, and press the SET key to enable the settings.</p>	

<Table of Audio Return Channel setting items>

(1)	VG Logical Address	This sets the logical address of the VG generator. (0 to F)	
(2)	Port (0/1)	This sets the port used for Audio Return Channel execution.	
	0 HDMI1	Audio Return Channel is executed using HDMI1.	
	1 HDMI2	Audio Return Channel is executed using HDMI2.	
(3)	Mode (0/1)	This sets the operation mode.	
	0 Use CEC	ARC start and end are controlled using the CEC commands.	
	1 Audio Monitor	The sound acquisition is started without using the CEC commands.	
(4)	CEC Command (0-2)	These set the operation to be performed when CEC (0) has been selected as the Mode setting.	
	0 Wait Request	Operation which accords with the ARC start and end requests from ARC TX is performed.	
	1 Initiate	ARC is started from ARC RX (VG). (The "Initiate ARC" command is sent.)	
	2 Terminate	ARC is ended from ARC RX (VG). (The "Terminate ARC" command is sent.)	
(5)	Follower: Mode (0/1)	This sets the send destination of the CEC commands.	
	0 Auto	The commands are sent to the adjoining device of the generator. *	
	1 Manual	A logical address is specified, and the commands are sent to this address.	
(6)	Follower: LogicalAddr	This sets the logical address where the commands are to be sent when Manual (1) has been selected as the Follower: Mode setting. (0-F)	



<Concerning operations when Auto (0) has been selected as the Follower: Mode setting>

- In order to define the adjoining device of the generator, the connection location of the generator is checked by reading the physical address of the EDID connected to the generator. An error results if it has been determined that this physical address cannot be obtained (because the EDID of the connection destination cannot be read or because the EDID is not the HDMI EDID, for instance). In a case like this, **EXECUTE** must be selected again.
- In order to define the adjoining device of the generator, a CED command is sent from the generator. An error results if the response to this command is illegal and the generator cannot define the adjoining device. In a case like this, **EXECUTE** must be selected again.
- If, based on the response to the command sent, it has been determined that two or more devices adjoin the generator (because their physical addresses are identical, for instance), the adjoining device is identified with the lower or lowest logical address is identified to be the adjoining device.

<Concerning the CEC response commands>

A response is given to the following reception commands while the ARC pattern is selected.

When Auto (0) has been selected as the Follower: Mode setting

Reception command		Response command	
Command	Send source	Command	Send destination
Give Physical Address	All sources	Report Physical Address * Only when it has been possible to obtain the physical address from the EDID * The Device Type of the address set by VG Logical Address is used as the Device Type among the parameters. However, other Device types are used for the addresses listed below. Ch: Reserved Dh: Reserved Eh: Video Processor Fh: No response	Broadcasts
Request ARC Initiation	Adjoining device	Initiate ARC	Adjoining device
Request ARC Termination	Adjoining device	Terminate ARC	Adjoining device

When Manual (1) has been selected as the Follower: Mode setting

Reception command		Response command	
Command	Send source	Command	Send destination
Request ARC Initiation	Follower: LogicalAddr setting	Initiate ARC	Follower: LogicalAddr setting
Request ARC Termination	Follower: LogicalAddr setting	Terminate ARC	Follower: LogicalAddr setting



Commands common to the **Manual and Auto Follower: Mode settings**

Reception command	Response command
Give Device Vendor ID	Device Vendor ID
Give System Audio Mode Status	System Audio Mode Status
Request Short Audio Descriptor	Report Short Audio Descriptor

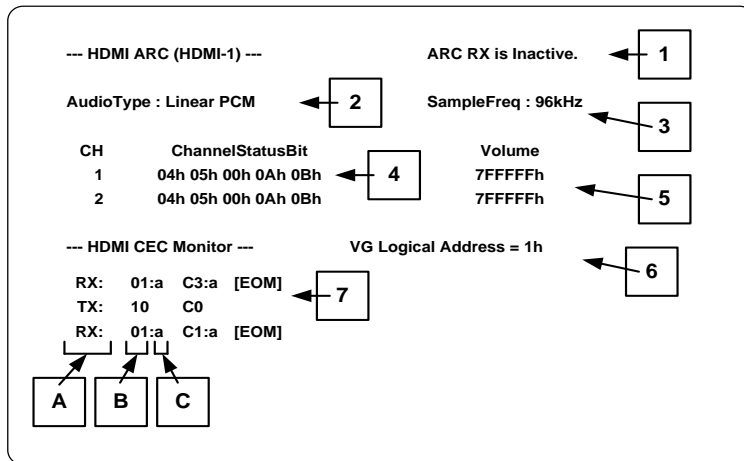

On the Audio Return Channel screen, the Audio data is displayed in the top part of the screen and the CEC send/receive data is displayed in the bottom part of the screen.

Only the Audio data is displayed when **Audio Monitor (1)** has been selected as the Mode setting.

<List of Audio data display area items>

(1)	Status display	The execution status of the generator's ARC function is displayed here.
	ARC RX is Inactive.	The ARC receive function has not been executed.
	ARC RX is Active.	The ARC receive function has been executed.
(2)	AudioType	The type of audio is displayed here.
(3)	SampleFreq	The sampling frequency is displayed here.
(4)	ChannelStatusBit	The channel statuses are displayed here.
(5)	Volume	The volume (peak) levels are displayed here. (Linear PCM only)

* When **Use CEC (0)** has been selected as the Mode setting, the Audio data will not be displayed unless the CEC command has been communicated properly.

<List of CEC data display area items>

(6)	VG Logical Address	The logical address of the generator is displayed here.
(7)	CEC send/receive data	The CEC command data sent from the generator or other devices is displayed here.
	(A) RX/TX	RX: These are the commands which have been received by the generator; TX: these are the commands which the generator has sent.
	(B) Data area	The block data is displayed here (00 to FF).
	(C) ACK area	The ACK data of the block is displayed here. (a: ACK present, n: ACK not present) * Only the commands received are displayed.

The following information is displayed in [] for (7):

[E_BUS]	When an attempt was made to send a command from the generator, the bus was not released so the command would not be sent.
[E_ACK]	ACK was not present in the command sent from the generator.
[E_ARB]	When a command was sent from the generator, another command came into conflict, and the transmission was not completed.
[EOM]	EOM of the block has been set. * This is displayed only for commands which have been received.

4.2.12 HDMI Ethernet Channel









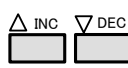

HDMI Ethernet Channel function execution and pattern display

* This function is available only for the below condition.

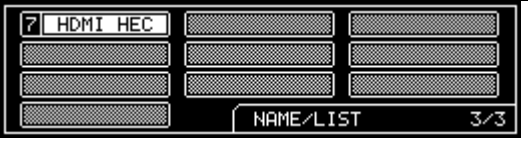
- HDMI 300MHz unit (VM-1823)
- When IA-1542 (HEAC Adaptor) is connected to HDMI1.4a Video Signal Generator (VG-870B / 871B) .
IA-1542 can not be used with VM-1817(HDMI 1.3) or VM-1823 (HDMI 300MHz).

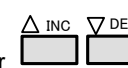
The below operation is for HDMI 300MHz unit (VM-1823). If you use IA-1542, please refer to IA-1542 Instruction Manual.

《HDMI Ethernet Channel execution pattern》

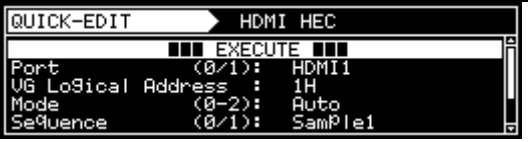
<p>1</p> <p>NAME/LIST DETAIL NAME/LIST DETAIL</p> 	
<p>2</p> <p>《Select HDMI HEC》</p> <p>By using  or ,</p> <p>Select HDMI HEC  </p>	
<p>3</p> <p>《Detail setting : select EDIT》</p> <p>By using  or ,</p> <p>Select EDIT  </p> <p>Or, select by  .</p> <p>After editing detail items, select EXECUTE, and press SET key. Then the setting becomes available.</p>	

《HDMI HEC General setting items》

(1)	Port(0/1)	Select a port to execute HEC test.
	0	HDMI1 HDMI1 executes HEC.
	1	HDMI2 HDMI2 executes HEC.
(2)	VG Logical Address	Set CEC Logical Address of VG main unit.
(3)	Mode (0-2)	Set a mode of HEC test.
	0	Auto Send CDC (Capability Discovery and Control) message, ping commands automatically.
	1	CDC Send CDC message.
	2	Network Send ping commands.

About Auto Mode

This mode is supposed to use in production line testing.

By sending/receiving CDC message, HEC function search, control of connected devices and ping commands transmission automatically.

《Setting item》

(1)	Sequence (0/1)	Select Test Sequence	
		0	Sample1
		1	Sample2
(2)	Target Logical Addr	Set CEC Logical Address of DUT (divide under test).	
(3)	Target IP Address	Set IP address of DUT.	

《Details of test sequence》

Sample1 : VG main unit becomes Activator, and execute Activation.

Sample2 : DUT becomes Activator and execute Activation to VG main unit.

Sample1 Operation flow

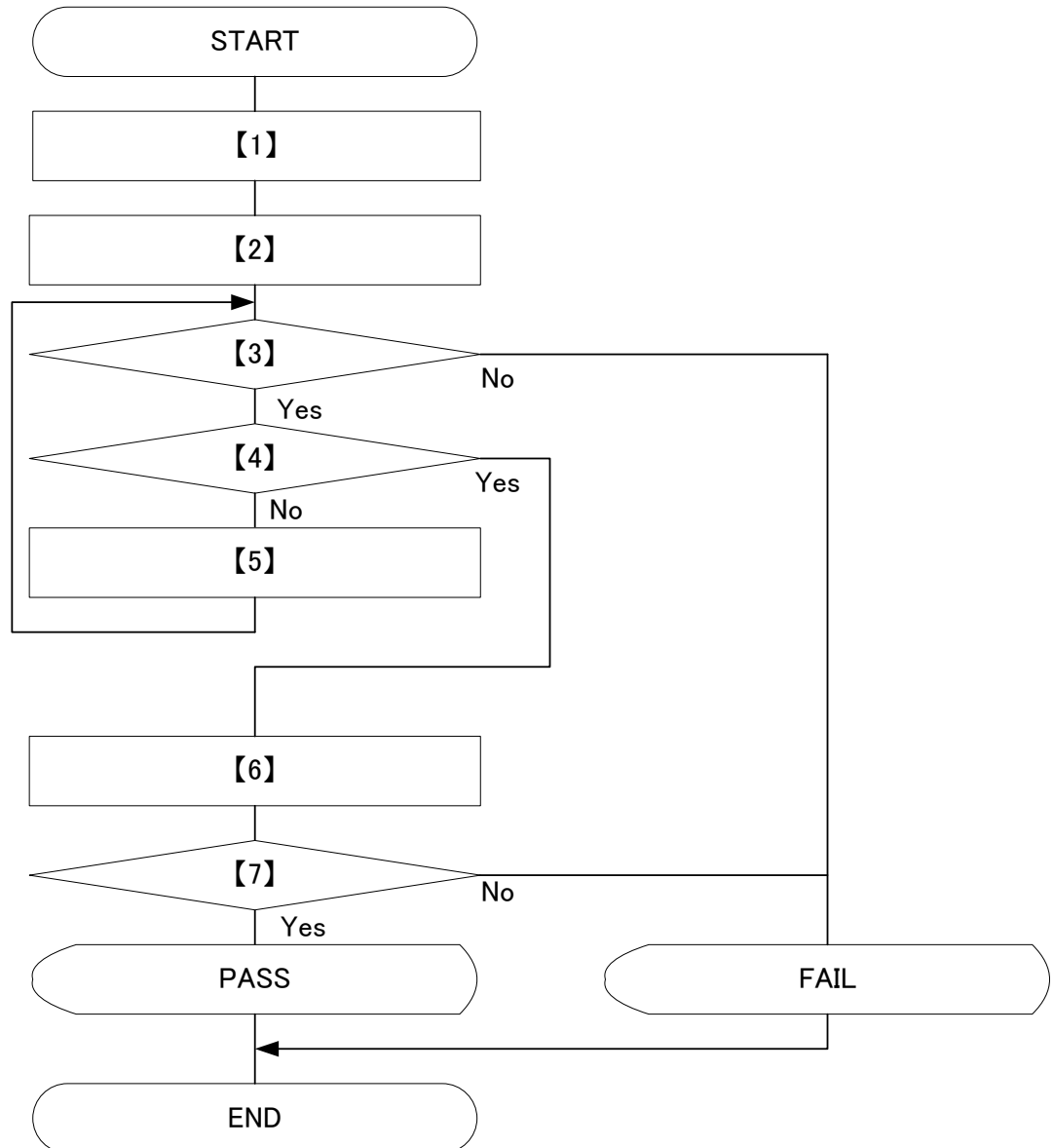

No.	Contents (Operation, condition to judge)	Details
[1]	Send <CDC_HEC_ReportState>	Physical Address of Target : 0xFFFF HEC Functionality State : HEC Active
[2]	Send <CDC_HEC_InquireState>	Terminating device 1 : VM-1823 Terminating device 2 : DUT (device under test)
[3]	Whether DUT responds <CDC_HEC_ReportState> or not.	
[4]	Whether DUT is HEC Active or not.	
[5]	Send <CDC_HEC_SetState>	Terminating device 1 : VM-1823, Terminating device 2 : DUT HEC Set State : Activate HEC
[6]	Send Ping	Source : VM-1823 IP Address, Destination : Target IP Address
[7]	Whether there is response or not.	

Sample2 Operation flow

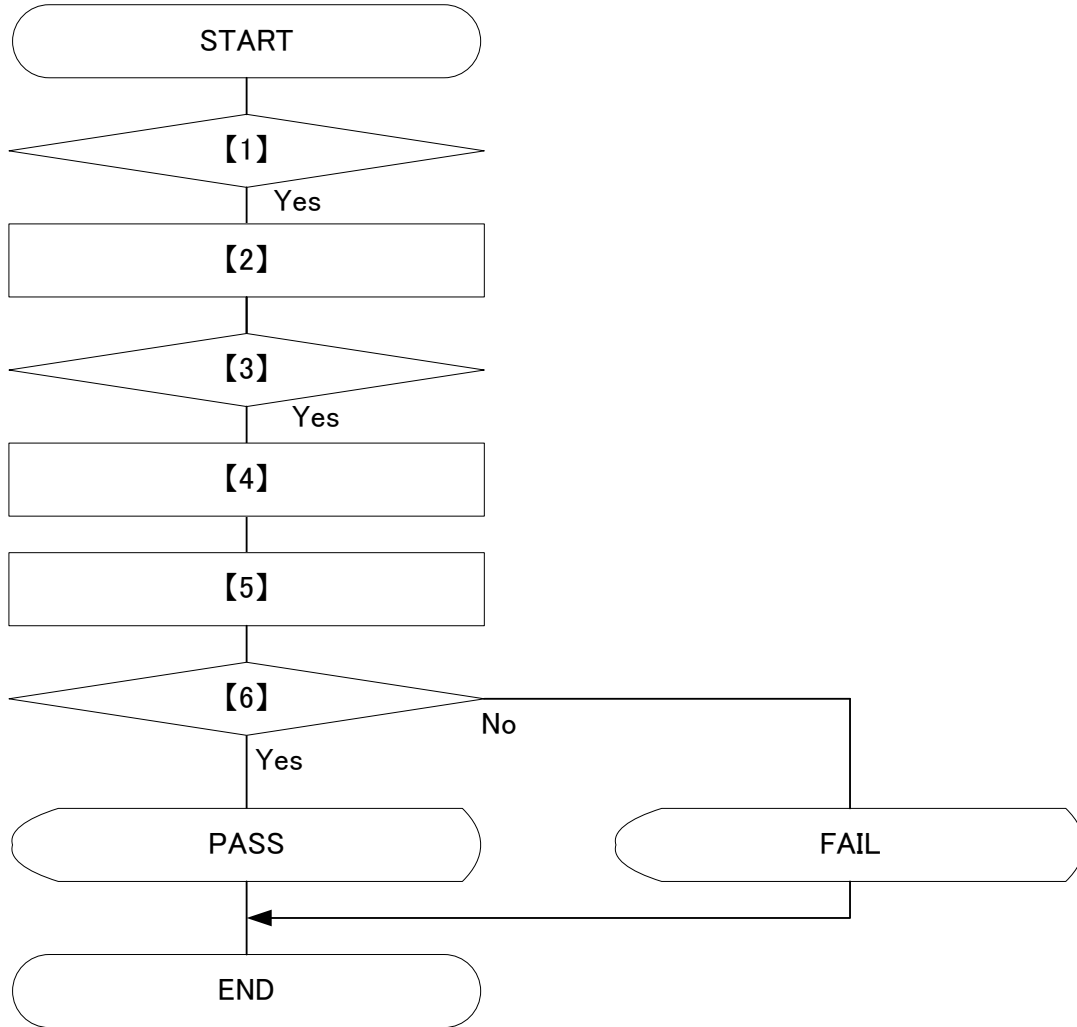

No.	Contents (Operation, condition to judge)	Details
[1]	Whether DUT sends <CDC_HEC_InquireState> or not.	
[2]	Send <CDC_HEC_ReportState>.	HEC Functionality State : HEC Inactive
[3]	Whether DUT sends <CDC_HEC_SetState> or not.	HEC Set State : Activate HEC
[4]	Send <CDC_HEC_ReportState>	HEC Functionality State : HEC Active
[5]	Send Ping	Source : VM-1823 IP Address Destination : Target IP Address
[6]	Whether there is response or not.	

Mode=CDC

In this mode, parameter of CDC message is edit and sent.

PASS/ FAIL criteria after CDC message transmission is different from each message. Please refer to HDMI standard about the detail of each CDC message.

《Setting item》

(1)	Target Logical Addr	Set CEC Logical Address of DUT. (This is used for result criteria when executing CDC Msg = 0, 3, 6)	
(2)	CDC Msg (0-6)	Select CDC message to send	
		0 Inquire State	<CDC_HEC_InquireState>
		1 Report State	<CDC_HEC_ReportState>
		2 Set State Adj	<CDC_HEC_SetStateAdjacent>
		3 Set State	<CDC_HEC_SetState>
		4 Req Deactivation	<CDC_HEC_RequestDeactivation>
		5 Notify Alive	<CDC_HEC_NotifyAlive>
		6 Discover	<CDC_HEC_Discover>

CDC Msg = 0 (Inquire State)**《Setting item》**

(1)	Dev Physical Addr1	Set Physical Address of the first Terminating Device.
(2)	Dev Physical Addr2	Set Physical Address of the second Terminating Device.

《Criteria of result judgment》

If the below condition is fulfilled, the test result becomes PASS.

- **DUT (the device designated by Target Logical Addr) is included in the channel designated by the Dev Physical Addr1 and the Dev Physical Addr2.**

and

- There is a response of <CDC_HEC_ReportState> from the DUT>.

Note : if the setting value of **Target Logical Addr** and the setting value of **VG Logical Address** are same (DUT=VG main unit), the result is FAIL.

CDC Msg = 1 (Report State)

《Setting item》

(1)	Dev Physical Addr	Set Physical address of the destination device of the message.	
(2)	HEC Func State (0-3)	Set HEC Functionality State	
		0	Not Supported
		1	Inactive
		2	Active
		3	Activation Field
(3)	Host Func State (0-2)	Set Host Functionality State.	
		0	Not Supported
		1	Inactive
		2	Active
(4)	ENC Func State (0-2)	Set ENC Functionality State.	
		0	Not Supported
		1	Inactive
		2	Active
(5)	CDC Error Code (0-3)	Set CDC Error Code.	
		0	No Error "No Error"
		1	Never Support "Initiator does not have the requested Capability"
		2	Can not respond "Initiator is not capable to carry out the request in this state"
		3	Other Error " Other Error"

《Criteria of result judgment》

After finish sending <CDC_HEC_ReportState>, judge it as PASS.

Note : the setting value of **Dev Physical Addr** and Physical Address of VG main unit are same (message destination = VG main unit), the result is FAIL.

Or, if the device set by **Dev Physical Addr** does not exist, the result is FAIL.

CDC Msg = 2 (Set State Adj)**《Setting item when CDC Msg = 2 (Set State Adj) is selected》**

(1)	Set Mode (0/1)	Select the setting method of the destination device of message.		
		0	Auto	Send message to the adjacent devices of VG main unit. * If there are several adjacent devices, the message is sent to the device that has smaller Logical Address.
		1	Manual	Message is sent to the device set in the below "Dev Physical Addr".
(2)	Dev Physical Addr	Set Physical Address of the destination device of message. (This is available only when Set Mode=1(Manual))		
(3)	HEC Set State (0/1)	Setting of the HEC Set State		
		0	Deactivate HEC	
		1	Activate HEC	

《Criteria of result judgment》

When either of below 2 conditions is fulfilled, the result is PASS.

Condition 1 **Set Mode = Auto**

- <CDC_HEC_ReportState> is responded by the adjacent devices of VG main unit.

Condition 2 **Set Mode = Manual**

- <CDC_HEC_ReportState> is responded from the device designated by **Dev Physical Addr**.

Note : when setting by **Set Mode=Manual**, if the setting value of **Dev Physical Addr** and Physical address of VG main unit are same (message destination = VG main unit), the result is FAIL.

Or, if the device set by **Dev Physical Addr** does not exist, the result is FAIL.

CDC Msg = 3 (Set State)**《Setting item》**

(1)	Dev Physical Addr1	Set Physical Address of the first Terminating Device.	
(2)	Dev Physical Addr2	Set Physical Address of the second Terminating Device.	
(3)	HEC Set State (0/1)	Setting of the HEC Set State	
		0	Deactivate HEC
		1	Activate HEC

《Criteria of result judgment》

If the below condition is fulfilled, the test result becomes PASS.

- DUT (the device designated by **Target Logical Addr**) is included in the channel designated by the **Dev Physical Addr1** and the **Dev Physical Addr2**.

and

- There is a response of <CDC_HEC_ReportState> from the DUT>.

CDC Msg = 4 (Req Deactivation)

《Setting item》

(1)	Act Physical Addr	Set Physical Address of Activator.
(2)	Dev Physical Addr1	Set Physical Address of the first Terminating Device.
(3)	Dev Physical Addr2	Set Physical Address of the second Terminating Device.

《Criteria of result judgment》

If the below condition is fulfilled, the test result becomes PASS.

- The device designated in the **Act Physical Addr** sends <CDC_HEC_SetState>[**Dev Physical Addr1**][**Dev Physical Addr2**][HEC Deactivate].

Note : if the setting value of **Act Physical Addr** and Physical Address of VG main unit are same, the result is FAIL.

Or, if the device set by **Act Physical Addr** does not exist, the result is FAIL.

CDC Msg = 5 (Notify Alive)

《Setting item》

(1)	Send Interval1	Set interval of sending <CDC_HEC_NotifyAlive> (0-150sec)
(2)	Send Interval2	Set interval of sending <CDC_HEC_NotifyAlive> (0-150sec)
(3)	Send Interval3	Set interval of sending <CDC_HEC_NotifyAlive> (0-150sec)
(4)	Send Time	Suppose 3 times of sending <CDC_HEC_NotifyAlive> is counted as one sequence, set how many sequence it is sent .

《Transmission image》

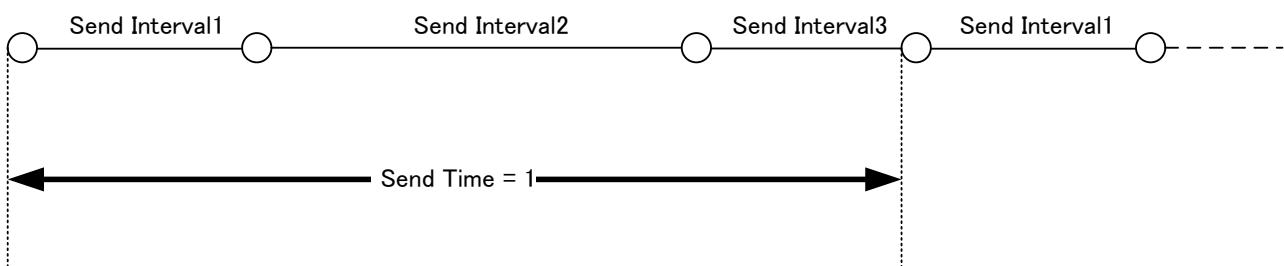

○ <CDC_HEC_NotifyAlive> 送信

《Criteria of result judgment》

Under above condition, after <CDC_HEC_NotifyAlive> is sent, the result becomes PASS.

CDC Msg = 6 (Discover)**《Criteria of result judgment》**

If the below condition is fulfilled, the test result becomes PASS.

- DUT (designated by **Target Logical Addr**) responds with <CDC_HEC_ReportState>.

Note : if the setting value of **Target Logical Addr** and **VG Logical Address** are same (DUT = VG main unit), the result is FAIL.

Mode = Network

In this mode, ping command (ICMP echo request) is sent to the DUT.

《Setting item》

(1)	Target IP Address	Set IP address of DUT.
-----	--------------------------	------------------------

《Criteria of result judgment》

If the below condition is fulfilled, the test result becomes PASS.

- The DUT (designated by **Target IP Address**) responds (ICMP echo reply).

Test result display

The screenshot shows a test result display for Port HDMI 1 (VM-1823). It is divided into two main sections: 'Devices' and 'Test Items'. Below these is a 'FAIL' status message with details.

1 Port : HDMI 1 (VM-1823)

2 Devices :

Physical Address / Logical Address

0 . 0 . 0 . 0 / 0 (TV)

* 1 . 0 . 0 . 0 / 1 (Recording Device1)

2 . 1 . 0 . 0 / 4 (Playback Device1)

2 . 0 . 0 . 0 / 5 (Recording Device 1)

3 Test Items : Sample 1

1 CDC <CDC_HEC_InquireState>
0 . 0 . 0 . 0 to 1 . 0 . 0 . 0

2 CDC <CDC_HEC_SetState> Active
0 . 0 . 0 . 0 to 1 . 0 . 0 . 0

3 Network <Ping>
IP Address
VM-1823 : 255 0 0 0
Target : 255 0 0 0
(TV)

4 CDC <CDC_HEC_SetState> Inactive
0 . 0 . 0 . 0 to 1 . 0 . 0 . 0

4 **FAIL** / 1 CDC <CDC_HEC_InquireState>
Target device didn't respond <CDC_HEC_ReportState>

5

6















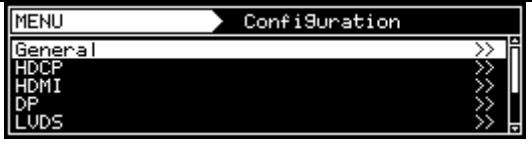



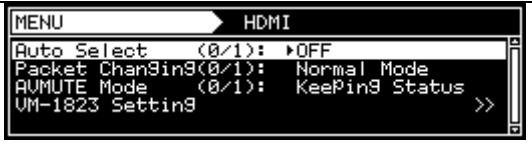

The test result is displayed as pattern as above picture.

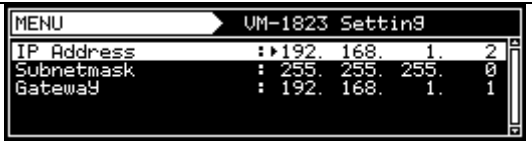
《HEC test result items list》

1	Execution port	Display the port to execute the test.
2	HDMI device information	Display the information (CEC Logical Address, Physical Address) of HDMI connected devices. “ * ” indicates VM-1823.
3	Test contents	Display the test contents. If the Mode is Auto, information of each step of test sequence is displayed.
4	Test result	“PASS” or “FAIL”
Below information is displayed only when the result is FAIL.		
5	FAIL detail status	Details status of error.
6	FAIL appeared step	When Mode is Auto, it displays in which step of sequence the “FAIL” status appears.

Network setting of HEC function

Set IP address, Subnet mask and gateway of VG main unit (VM-1823).

①	By  →  or   , select Configuration → 	 <pre> MENU Configuration General >> HDCP >> HDMI >> DP >> LVDS >> </pre>												
②	By  or   , select HDMI → 	 <pre> MENU HDMI Auto Select (0/1): OFF Packet Changing(0/1): Normal Mode AUMUTE Mode (0/1): Keepin9 Status VM-1823 Setting >> </pre>												
③	By  or   , select VM-1823 Setting → 	 <pre> MENU VM-1823 Setting IP Address : 192.168.1.2 Subnetmask : 255.255.255.0 Gateway : 192.168.1.1 </pre>												
④	《Input parameter》 By  or   , select it →  Or  ~  (by number key) select it → 	<table border="1"> <tbody> <tr> <td colspan="2">IP Address</td> </tr> <tr> <td>xxxxxxxxxx</td> <td>Set IP address Factory default is 192.168.1.2</td> </tr> <tr> <td colspan="2">Subnetmask</td> </tr> <tr> <td>xxxxxxxxxx</td> <td>Set Subnet mask. Factory default is 255.255.255.0.</td> </tr> <tr> <td colspan="2">Gateway</td> </tr> <tr> <td>xxxxxxxxxx</td> <td>Set Gateway. Factory default is 192.168.1.1.</td> </tr> </tbody> </table>	IP Address		xxxxxxxxxx	Set IP address Factory default is 192.168.1.2	Subnetmask		xxxxxxxxxx	Set Subnet mask. Factory default is 255.255.255.0.	Gateway		xxxxxxxxxx	Set Gateway. Factory default is 192.168.1.1.
IP Address														
xxxxxxxxxx	Set IP address Factory default is 192.168.1.2													
Subnetmask														
xxxxxxxxxx	Set Subnet mask. Factory default is 255.255.255.0.													
Gateway														
xxxxxxxxxx	Set Gateway. Factory default is 192.168.1.1.													

4.3 DVI

DVI output connectors are provided on the PC analog unit (VM-1811) and DVI unit (VM-1814).

The specifications differ for each of the connectors so refer to the table below.

Unit/connector	Dual-Link	HDCP	Analog
PC analog unit	-	○	○
DVI unit DVI1	○	-	-
DVI unit DVI2	-	○	-

4.3.1 Connectors and pin assignments

- Connector: DVI-I (74320-1004) made by Morex
- Output: TMDS

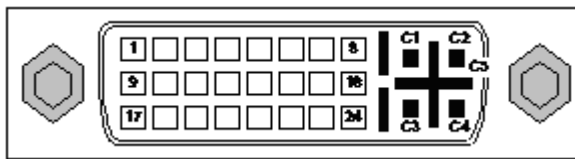























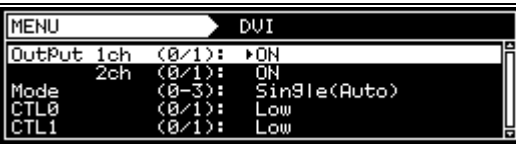

Pin no.	Signal	Pin no.	Signal	Pin no.	Signal
1	TMDS DATA2-	9	TMDS DATA1-	17	TMDS DATA0-
2	TMDS DATA2+	10	TMDS DATA1+	18	TMDS DATA0+
3	TMDS DATA2/4 G	11	TMDS DATA1/3 G	19	TMDS DATA0/5 G
4	TMDS DATA4-	12	TMDS DATA3-	20	TMDS DATA5-
5	TMDS DATA4+	13	TMDS DATA3+	21	TMDS DATA5+
6	DDC CLK	14	+5 V (DDC power supply *1)	22	TMDS CLK G
7	DDC DATA	15	Ground	23	TMDS CLK+
8	Analog Vsync	16	SENSE	24	TMDS CLK-
C1	Analog Red				
C2	Analog Green				
C3	Analog Blue				
C4	Analog Hsync				
C5	Analog Ground				

*1: Restrictions apply to the supply current of the DDC power supply. Refer to “**12.3 Concerning the maximum current consumption of the DDC (DP_PWR) power supply.**”

4.3.2 DVI unit setting procedure































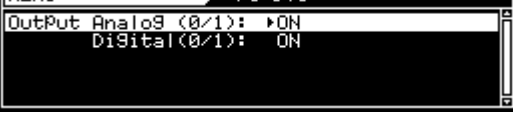

<DVI unit setting procedure>

<p>(1) Select Program Edit using  or , and then press .</p>	
<p>(2) Select Output (TIM) using  or , and then press .</p>	
<p>(3) Select Digital Output using  or , and then press .</p>	
<p>(4) Select DVI using  or , and then press .</p>	
<p>(5) Select the items using  or , and then press .</p> <p><Inputting the parameters></p> <p>Select the parameters using  or , and then press .</p> <p>Alternatively: Select the parameters using the number keys ( to ) , and then press .</p>	<p>For further details on the parameters, refer to the table below.</p>

<DVI unit setting parameters>

(1)	Output 1ch (0/1) Output 2ch (0/1)	This sets On or Off for each channel. The same settings as the ones described in "4.1.1 Setting the output interfaces to ON or OFF" can also be established.		
		0	Off	No output.
		1	On	Output.
(2)	Mode (0/1)	This sets the bit length and link format of the images to be output from DVI. A setting which is independent of the bit length for pattern drawing can be selected. It is also possible to select the bit length automatically. The portion by which the bit length for pattern drawing exceeds the bit length which has been set here is discarded. A deficient portion is filled with zeros. "Single" can be selected when the dot clock frequency ranges from 25 MHz to 165 MHz, and data can be output from output channels 1 and 2. "Dual" can be selected when the dot clock frequency ranges from 50 MHz to 330 MHz, and data can be output from output channel 1. Data is not output from channel 2. "4.1.5 Setting the bit length (gray scale) for pattern drawing"		
		0	Single (8 bits)	The data is output by Single Link from output channels 1 and 2. The portion by which the bit length for pattern drawing exceeds 8 bits is discarded.
		1	Dual (8 bits)	The data is output by Dual Link from output channel 1. The portion by which the bit length for pattern drawing exceeds 8 bits is discarded. Data is not output from channel 2.
		2	Single (16 bits)	Up to 16 bits are output by Single Link using the two links of output channel 1. The portion by which the bit length for pattern drawing is deficient from the bit length which has been set here is filled with zeros. The data is output by Single Link from output channels 2. The portion by which the bit length for pattern drawing exceeds 8 bits is discarded.
		3	Single (Auto)	The data is output by Single Link from output channels 1 and 2. Single (8 bits) or Single (16 bits) is automatically selected depending on the bit length for pattern drawing.
(3)	CTL0/CTL1	This is not normally used. Keep it at the low setting.		

4.3.3 PC analog unit (DVI) setting procedure

(1)	Select Program Edit using  →  or   , and then press  .	 <pre> MENU Program Edit Program Name : ▶EIA1920x1080P@60 Timing (TIM) >>> Output (TIM) >>> Audio (TIM) >>> Pattern (PAT) >>> </pre>						
(2)	Select Output (TIM) using  or   , and then press  .	 <pre> MENU OutPut All OutPut >>> Analog OutPut >>> Digital OutPut >>> VBI Function >>> </pre>						
(3)	Select Analog Output using  or   , and then press  .	 <pre> MENU Analog OutPut General >>> PC: RGB (BNC) >>> PC: UGA (D-Sub) >>> PC: DVI >>> TV: COMPOSITE >>> </pre>						
(4)	Select DVI using  or   , and then press  .	 <pre> MENU PC-DVI OutPut Analog (0/1): ▶ON Digital(0/1): ON </pre>						
(5)	Select Output Analog using  or   , and then press  .	The same settings as the ones described in “4.1.1 Setting the output interfaces to ON or OFF” can also be established.						
<p><Inputting the parameters></p> Select the parameters using  or   , and then press  . Alternatively: Select the parameters using the number keys 0/STATUS  to  9/F  , and then press  .		<table border="1"> <tbody> <tr> <td>0</td> <td>Off</td> <td>No output.</td> </tr> <tr> <td>1</td> <td>On</td> <td>Output.</td> </tr> </tbody> </table>	0	Off	No output.	1	On	Output.
0	Off	No output.						
1	On	Output.						

4.3.4 DVI data transfer systems

<Specifications with 8-bit output>

[Single (8 bit)]

The same images are output to all channels 1 and 2. The output level is 8 bits.

Given here as an example for explanatory purposes is a case where the resolution is 1280 × 1024, the dot clock frequency is 108 MHz with 8 bits level.

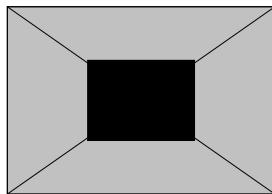
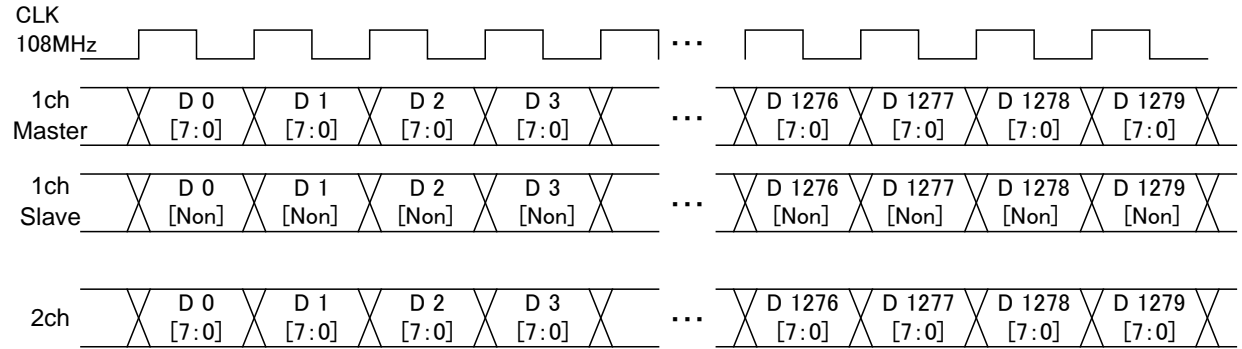

1CH Master

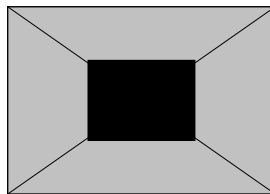

2CH

[Dual (8 bit)]

The images are output with channel 1 master and channel 1 slave making a pair. 8 bits level is output.

During dual output, the channel 2 output goes OFF.

Given here as an example for explanatory purposes is a case where the resolution is 1280×1024 , the dot clock frequency is 108 MHz with 8 bits level.

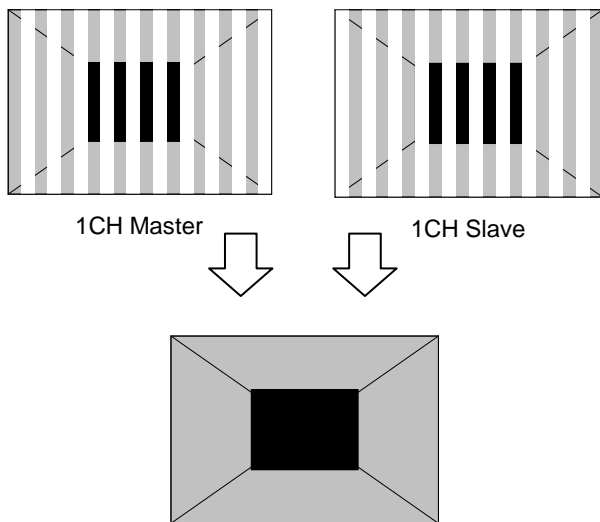
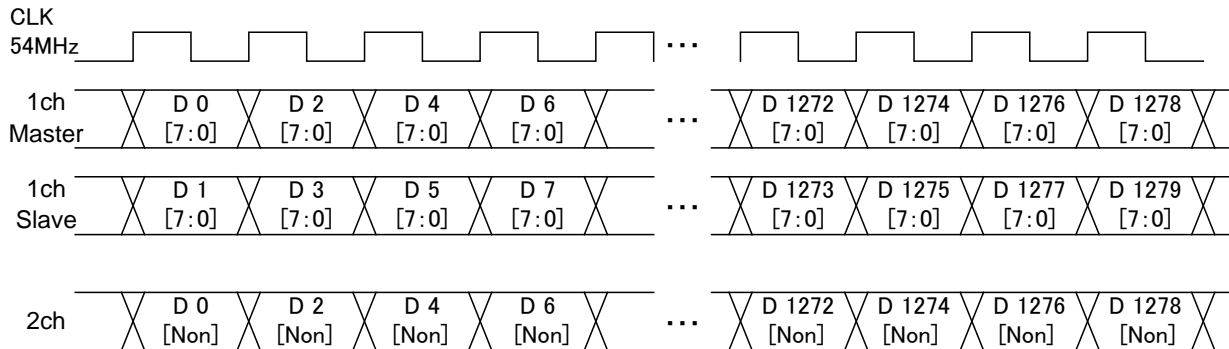

<Specifications with 16-bit output>**[Single (16bit)]**

The 16-bit images are output with channel 1 master and channel 1 slave making a pair.

The higher 8 bits are output to the channel 1 master and the lower 8 bits to the channel 1 slave.

With channel 2, the higher 8 bits are output, and the lower bits are discarded.

Given here as an example for explanatory purposes is a case where the resolution is 1280×1024 , the dot clock frequency is 108 MHz and the 16 bits output consisting of 8 bits for channel 1 and 8 bits for channel 2.

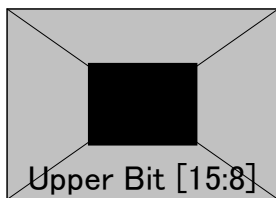
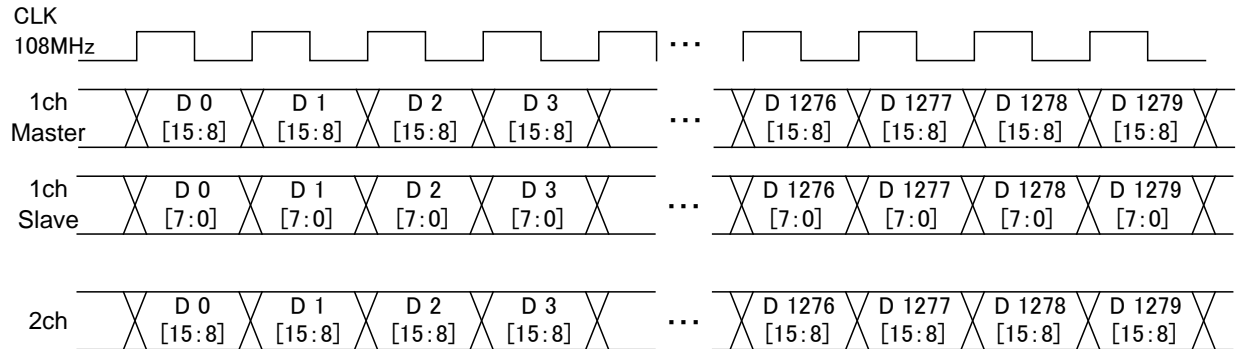

1CH Master

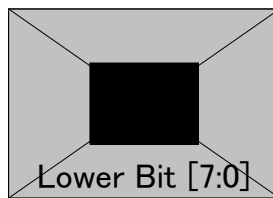

1CH Slave

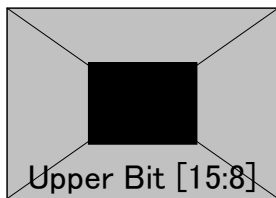

2CH

4.3.5 Sync signal polarity setting

For further details on the setting procedure, refer to “4.1.2 Setting the sync signals to ON or OFF and setting the sync signal polarities.” The same settings are established for both the DVI analog and digital signals.

4.3.6 EDID

For further details on the setting procedure, refer to “6.13.3 EDID.”

Note: The DDC_CLK frequency of DVI (channel 1) is fixed at 40 kHz. It does not exist in DDC_CLK of Configuration. Also, the DDC_CLK frequency of DVI (channel 2) changes in tandem with DDC_CLK of Configuration.

4.3.7 HDCP

For further details on the setting procedure, refer to “8.1 HDCP settings.”

4.3.8 DDC/CI

For further details on the setting procedure, refer to “6.13.4 DDC/CI.”

4.4 4K2K (iTMDs, iTMDs Quad) (VM-1824, VM-1824-A)

The specifications differ for each of the connectors so refer to the table below.

Unit/connector	Dual-Link	HDCP	Analog
iTMDs unit (VM1824) 1CH	○	-	-
iTMDs unit (VM1824) 2CH	○	-	-
iTMDs Quad unit (VM1824-A) 1CH	-	-	-
iTMDs Quad unit (VM1824-A) 2CH	-	-	-
iTMDs Quad unit (VM1824-A) 3CH	-	-	-
iTMDs Quad unit (VM1824-A) 4CH	-	-	-

4.4.1 Connectors and pin assignments

- Connector: DVI-I (74320-1004) made by Morex
- Output: iTMDs, TMDS (8-bit DVI compatible mode)

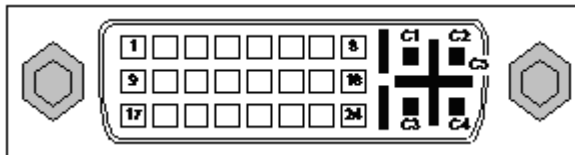





























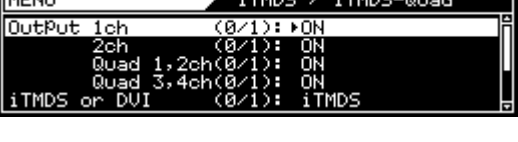



Pin no.	Signal	Pin no.	Signal	Pin no.	Signal
1	TMDS DATA2-	9	TMDS DATA1-	17	TMDS DATA0-
2	TMDS DATA2+	10	TMDS DATA1+	18	TMDS DATA0+
3	TMDS DATA2/4 G	11	TMDS DATA1/3 G	19	TMDS DATA0/5 G
4	TMDS DATA4-	12	TMDS DATA3-	20	TMDS DATA5-
5	TMDS DATA4+	13	TMDS DATA3+	21	TMDS DATA5+
6	DDC CLK	14	+5 V (DDC power supply *1)	22	TMDS CLK G
7	DDC DATA	15	Ground	23	TMDS CLK+
8	Analog Vsync	16	SENSE	24	TMDS CLK-
C1	Analog Red				
C2	Analog Green				
C3	Analog Blue				
C4	Analog Hsync				
C5	Analog Ground				

*1: Restrictions apply to the supply current of the DDC power supply. Refer to “12.3 Concerning the maximum current consumption of the DDC (DP_PWR) power supply.”

4.4.2 4K2K (iTMS) unit setting procedure

<4K2K (iTMS) unit setting procedure>

<p>(1) Select Program Edit using  →  or  INC  DEC, and then press .</p>	 <pre> MENU Program Edit Program Name : ▶EIA1920x1080P60 Timing (TIM) >>> OutPut (TIM) >>> Audio (TIM) >>> Pattern (PAT) >>> </pre>
<p>(2) Select Output (TIM) using  or  INC  DEC, and then press .</p>	 <pre> MENU OutPut All OutPut >>> Analog OutPut >>> Digital OutPut >>> UBI Function >>> </pre>
<p>(3) Select Digital Output using  or  INC  DEC, and then press .</p>	 <pre> MENU Digital OutPut General >>> DUI >>> iTMS / iTMS-Quad >>> HDMI >>> DP >>> </pre>
<p>(4) Select iTMS using  or  INC  DEC, and then press .</p>	 <pre> MENU iTMS / iTMS-Quad OutPut 1ch (0/1): ▶ON 2ch (0/1): ON Quad 1,2ch(0/1): ON Quad 3,4ch(0/1): ON iTMS or DUI (0/1): iTMS </pre>
<p>(5) Select the items using  or  INC  DEC, and then press .</p> <p><Inputting the parameters></p> <p>Select the parameters using  or  INC  DEC, and then press .</p> <p>Alternatively: Select the parameters using the number keys ( to ), and then press .</p>	<p>For further details on the parameters, refer to the table below.</p>

<iTMDS (4Kx2K) unit setting parameters>

(1)	Output 1ch (0/1) Output 2ch (0/1) Output Quad 1,2ch (0/1) Output Quad 3,4ch (0/1)	This sets On or Off for each channel. The same settings as the ones described in “4.1.1 Setting the output interfaces to ON or OFF” can also be established.	
		0	Off No output.
		1	On Output.
(2)	iTMDs or DVI (0/1)	This sets the output signal format.	
		0	DVI The signals are output as DVI compatible signals. Eight bits per link are output.
		1	iTMDs The signals are output as iTMDs signals. Twelve bits per link are output.
(3)	Mode (0/6)	This sets the bit length and link format of the images to be output from iTMDs. A setting which is independent of the bit length for pattern drawing can be selected. It is also possible to select the bit length automatically. The portion by which the bit length for pattern drawing exceeds the bit length which has been set here is discarded. A deficient portion is filled with zeros.	
		<ul style="list-style-type: none"> ● When the dot clock frequency is in the range of 25 MHz to 165 MHz, Single Link can be selected, and the data can be distributed to and output from output channels 1 and 2. With the VM-1824-A, the data can be distributed to and output from channels 1, 2, 3 and 4. ● When the dot clock frequency is in the range of 50 MHz to 330 MHz, Dual Link can be selected, and the data can be distributed to and output from output channels 1 and 2. With the VM-1824-A, the data of channels 1 and 2 and the data of channels 3 and 4 are combined and output by Dual Link. ● When the dot clock frequency is in the range of 296 MHz to 660 MHz, Quad Link can be selected, and the data can be output using output channels 1 and 2. With the VM-1824-A, the data of channels 1, 2, 3 and 4 is combined and output by Quad Link. ● When the dot clock frequency is in the range of 592 MHz to 1320 MHz, by selecting Octal Link and by using two output boards, the data can be output by combining the data of board #1 output channels 1 and 2 and the data of board #2 output channels 1 and 2. With the VM-1824-A, the data of board #1 channels 1, 2, 3 and 4 and data of board #2 channels 1, 2, 3 and 4 are combined and output by Octal Link. 	
		<ul style="list-style-type: none"> * In the Quad Link or Octal Link mode, the 4Kx2K screen splitting operation which uses the frame memory on the board or boards is performed. * With the VM-1824-A, the Dual Link outputs of the VM-1824 are replaced with Single Link outputs. Channel 1 of Dual Link corresponds to channels 1 and 2 of Single Link. Similarly, channel 2 of Dual Link corresponds to channels 3 and 4 of Single Link. 	
		“4.1.5 Setting the bit length (gray scale) for pattern drawing”	
		0	Single (8bit) The data is output by Single Link from output channels 1 and 2. The portion by which the bit length for pattern drawing exceeds 8 bits is discarded. (Max. 12 bits with the iTMDs format)
		1	Dual (8bit) The data is output by Dual Link from output channels 1 and 2. The portion by which the bit length for pattern drawing exceeds 8 bits is discarded. (Max. 12 bits with the iTMDs format)
		2	Quad (8bit) The data is output by Quad Link using output channels 1 and 2. The portion by which the bit length for pattern drawing exceeds 8 bits is discarded. (Max. 12 bits with the iTMDs format) The 4Kx2K screen splitting operation which uses the frame memory on the board is performed. For details on the screen splitting method, refer to “Split” in the next section.

		3	Octal (8bit)	<p>By using two output boards, the data is output by Octal Link by combining the data of board #1 output channels 1 and 2 and the data of board #2 output channels 1 and 2. The portion by which the bit length for pattern drawing exceeds 8 bits is discarded. (Max. 12 bits with the iTMDS format)</p> <p>The 4Kx2K screen splitting operation which uses the frame memory on the board is performed. For details on the screen splitting method, refer to "Split" in the next section.</p>
		3	Single (16bit)	<p>Up to 16 bits can be output by Single Link using the two links--Master and Slave--of one connector. The portion by which the bit length for pattern drawing is deficient from the bit length which has been set here is filled with zeros.</p> <p>The higher bits are output to the Master and the lower bits to the Slave.</p>
		4	Dual (16bit)	<p>Up to 16 bits can be output by Dual Link using two connectors. The portion by which the bit length for pattern drawing is deficient from the bit length which has been set here is filled with zeros.</p> <p>The higher bits are output to output channel 1 and the lower bits to output channel 2.</p>
		5	Single (Auto)	<p>The data is output by Single Link from output channels 1 and 2. Single (8 bits) or Single (16 bits) is automatically selected depending on the bit length for pattern drawing.</p>
		6	Dual (Auto)	<p>The data is output by Single Link from output channels 1 and 2. Single (8 bits) or Single (16 bits) is automatically selected depending on the bit length for pattern drawing.</p>

(4)	Split (0/9)	This selects the screen splitting method for the 4Kx2K screen splitting operation which uses the frame memory on the board or boards.		
		QuadLink		
		0	MODE0	Screen split-into-4 output in the form of a square divided into 4 equal parts
		1	MODE1	Screen vertically split-into-4 output
		2	MODE2	Screen horizontally split-into-2 output
		3	MODE3	Screen vertically split-into-2 output
		4	MODE4	No split
		5	MODE0 (x4 Mode)	No screen splitting (Non Dividing Mode)
		6	MODE1 (x4 Mode)	Screen splitting (1) (Normal Mode)
		7	MODE2 (x4 Mode)	Screen splitting (2) (Cross Mode)
		8	MODE3 (x4 Mode)	Screen splitting (3) (Dividing Normal Mode)
		9	MODE4 (x4 Mode)	Screen splitting (4) (Dividing Cross Mode)
		Octal Link		
		0	MODE0	Cross-split-into-4 + Vertically split-into-2 output
		1	MODE1	Vertically split-into-4 + vertically split-into-2 output
		2	MODE2	Horizontally split-into-2 + screen vertically split-into-2 output
		3	MODE3	Vertically split-into-2 + vertically split-into-2 output
		4	MODE4	Vertically split-into-2 + Non-dividing(1) (Non dividing mode)
		5	MODE5	Vertically split-into-2 + Non-dividing(2) (Normal mode)
		6	MODE6	Vertically split-into-2 + Non-dividing (3) (Cross mode)
7	MODE7	Vertically split-into-2 + dividing (1) (Dividing Normal mode)		
8	MODE8	Screen vertically split-into-2 + dividing (2) (Dividing Cross mode)		
9	MODE9	No dividing		
(5)	CTL0/CTL1	This is not normally used. Keep it at the low setting.		

4.4.3 iTMDS data transfer systems

Specifications for Quad Link modes during 4Kx2K mode output

During 4Kx2K mode output, the data of four channels are combined using Dual Link equivalent to two channels to output one screen.

- * As shown in the figure below, what is output as the data of channels 1 to 4 for the Master and Slave of Dual Link of VM-1824 is described in this section.
- * Also described below in this section is the Single Link data of the VM-1824-A which is output as the data of channels 1 to 4.

[4Kx2K 4-channel output]

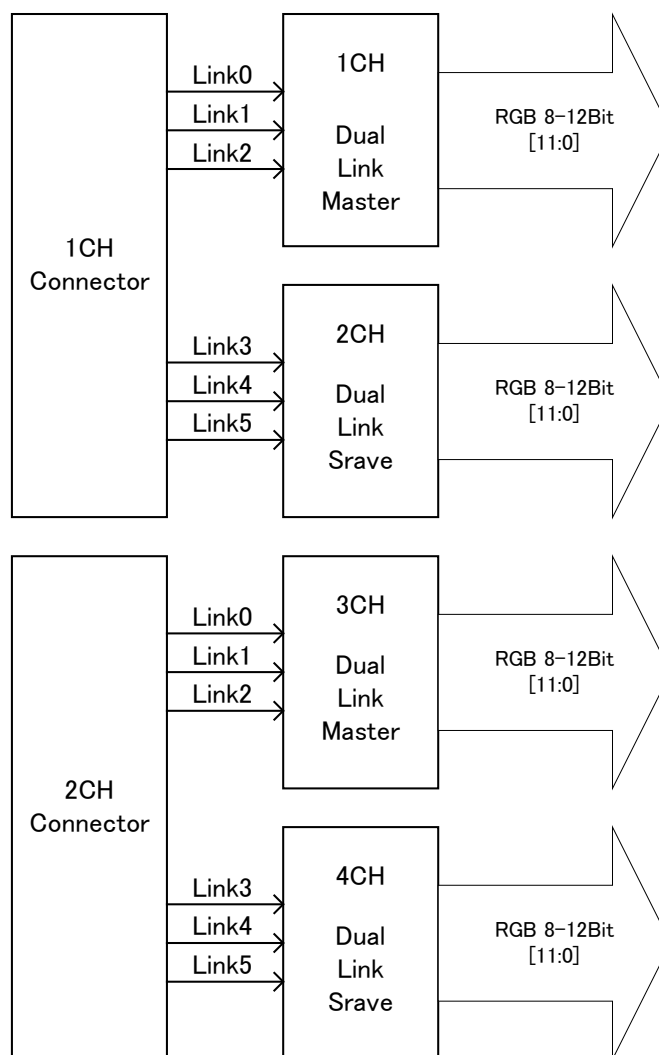

[1] MODE0 (Quad Link) (screen cross-split-into-4 output)

The screen is split into 4 equal parts using channels 1, 2, 3 and 4.

Given here as an example of the resolution is 4096 x 2048, the dot clock frequency is 592 MHz with the 10 bits output.

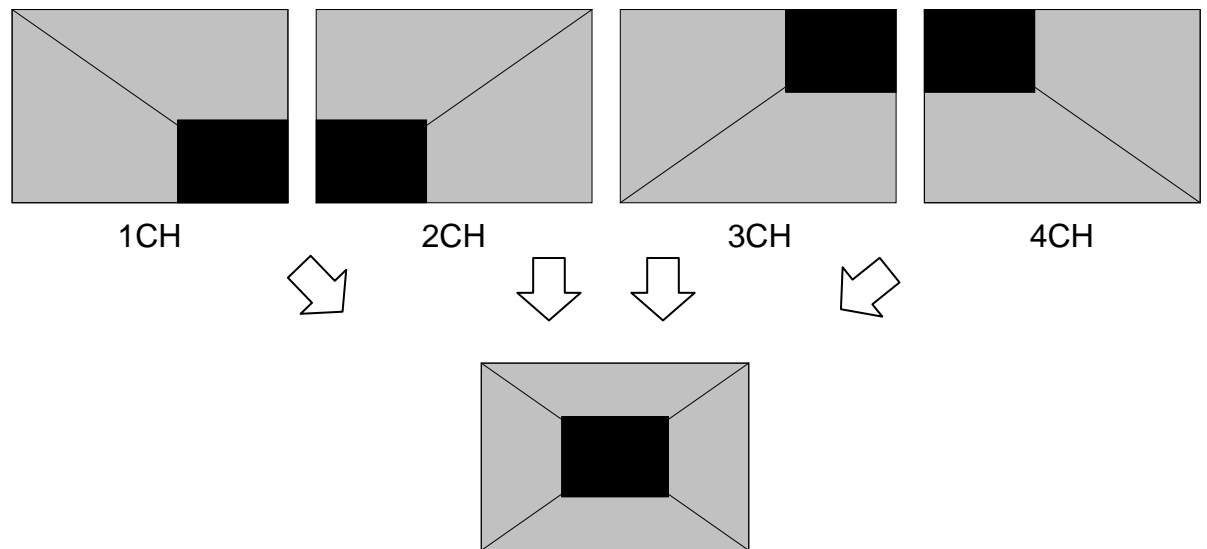
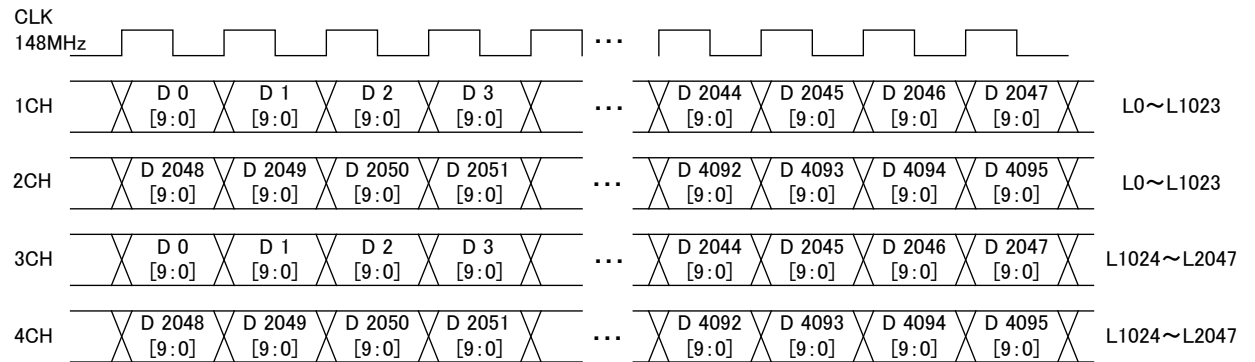

[2] MODE1 (QuadLink) (screen vertically split into 4)

The screen is split vertically into four parts and allocated from the left in the sequence of channel 1, channel 3, channel 2 and channel 4.

Given here as an example of the resolution is 4096 × 2048, the dot clock frequency is 592 MHz with the 10bits output.

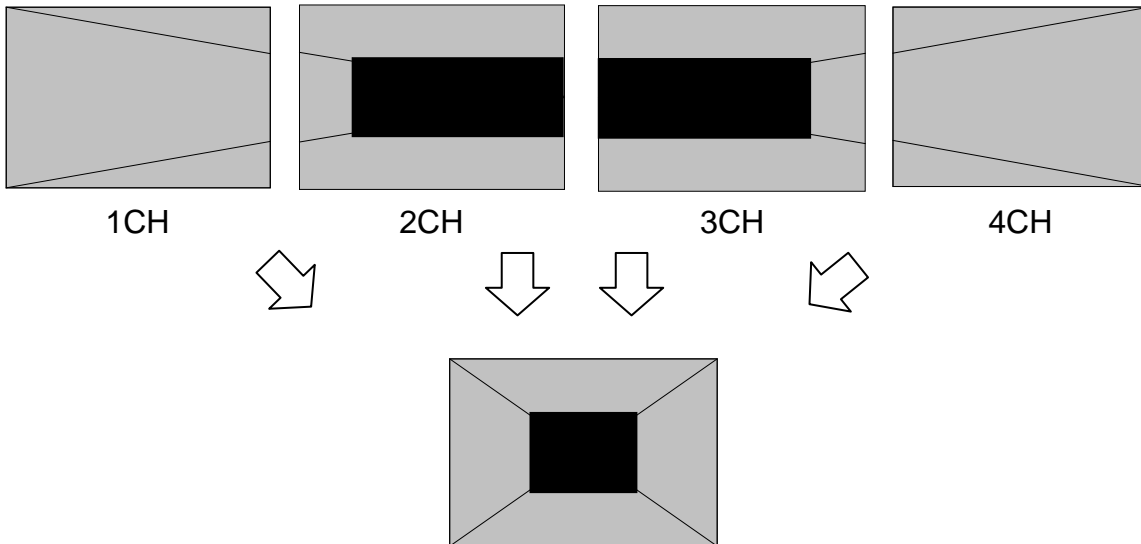
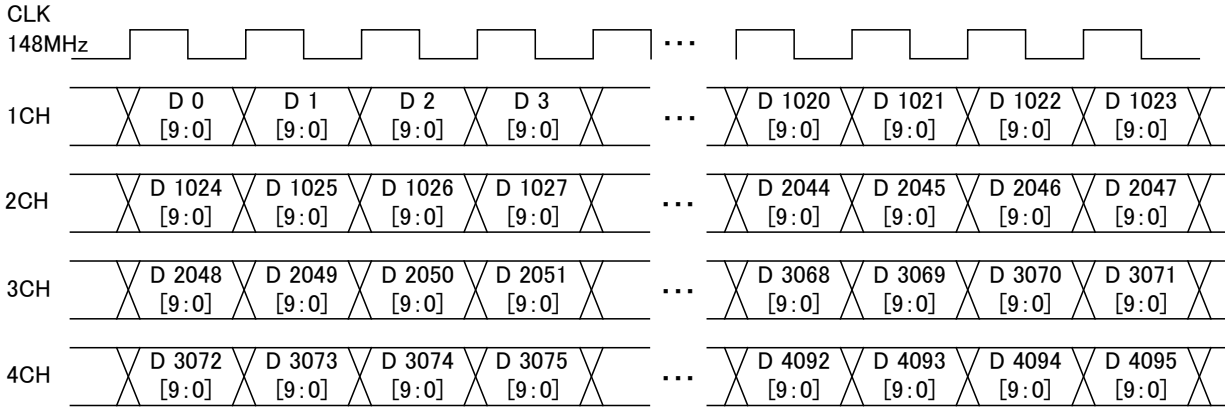

[3] MODE2 (Quad Link) (screen horizontally split into 2)

Using channels 1 and 2, the top half of the image is output in the even and odd numbers; similarly, using channels 3 and 4, the bottom half of the image is output in the even and odd numbers.

Given here as an example of the resolution is 4096 × 2048, the dot clock frequency is 592 MHz with 10bits output.

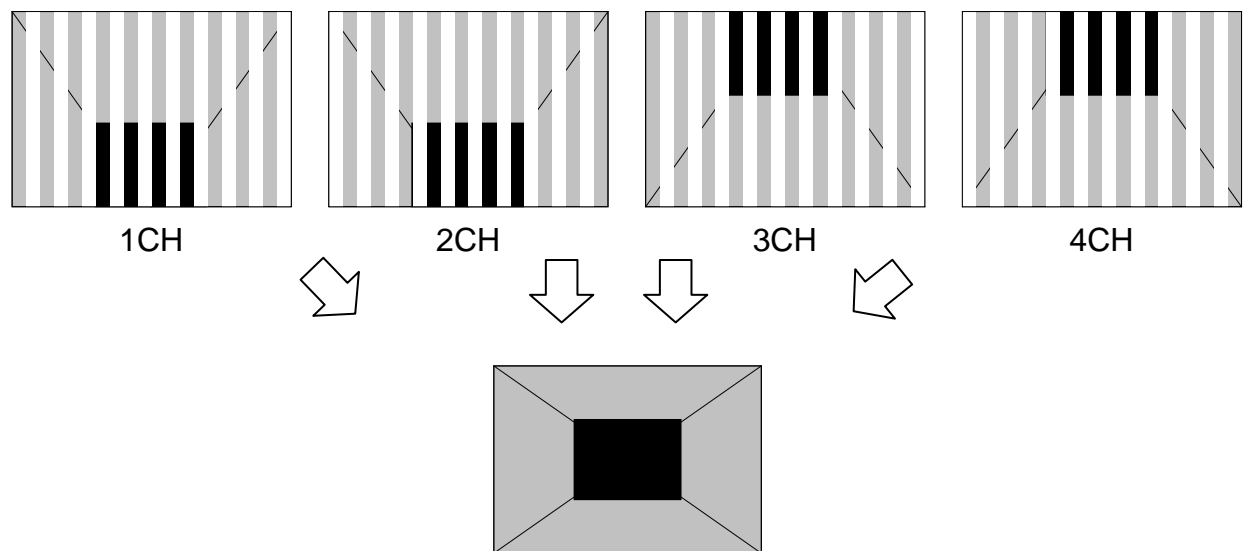
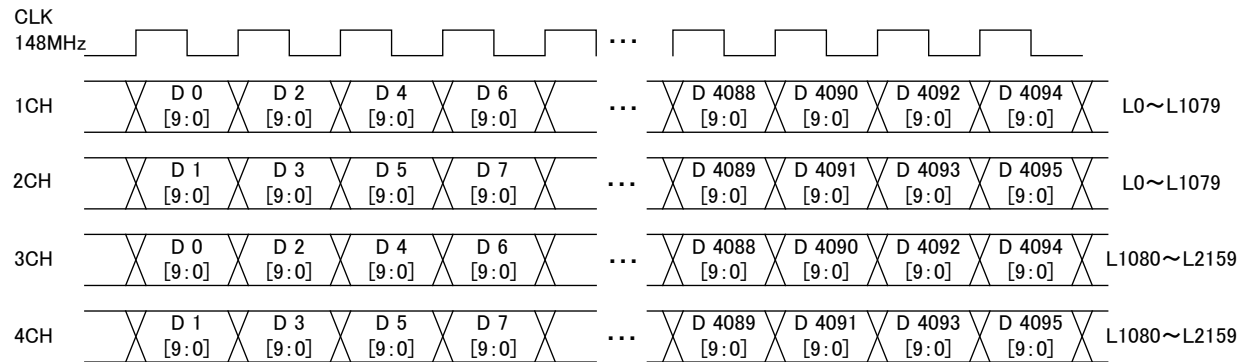

[4] MODE3 (Quad Link) (screen vertically split into 2)

Using channels 1 and 2, the left half of the image is output in the even and odd numbers; similarly, using channels 3 and 4, the right half of the image is output in the even and odd numbers.

Given here as an example of the resolution is 4096 × 2048, the dot clock frequency is 592 MHz with the 10 bits output.

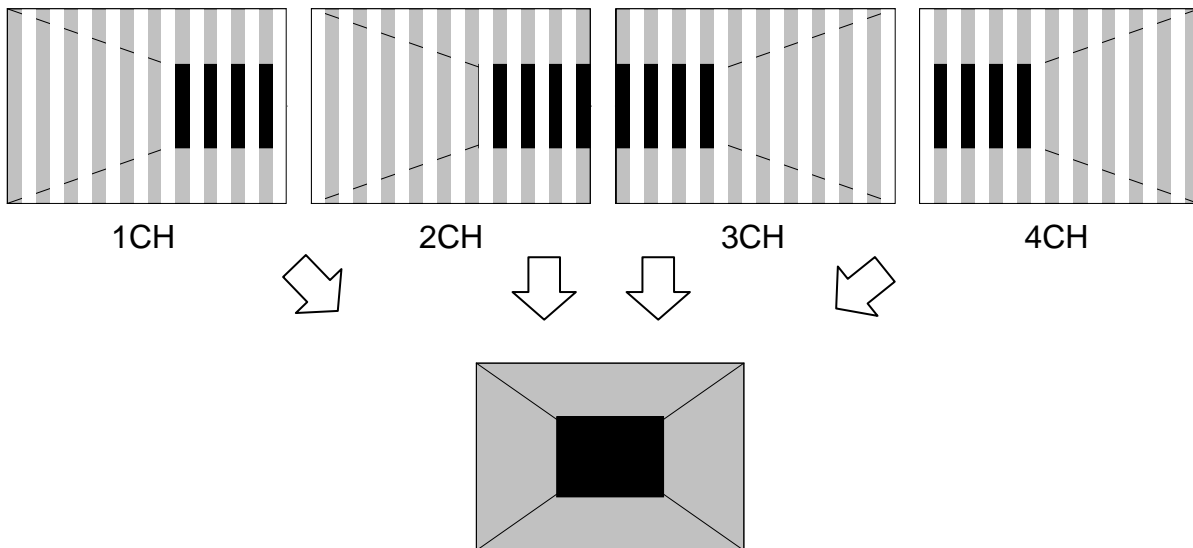
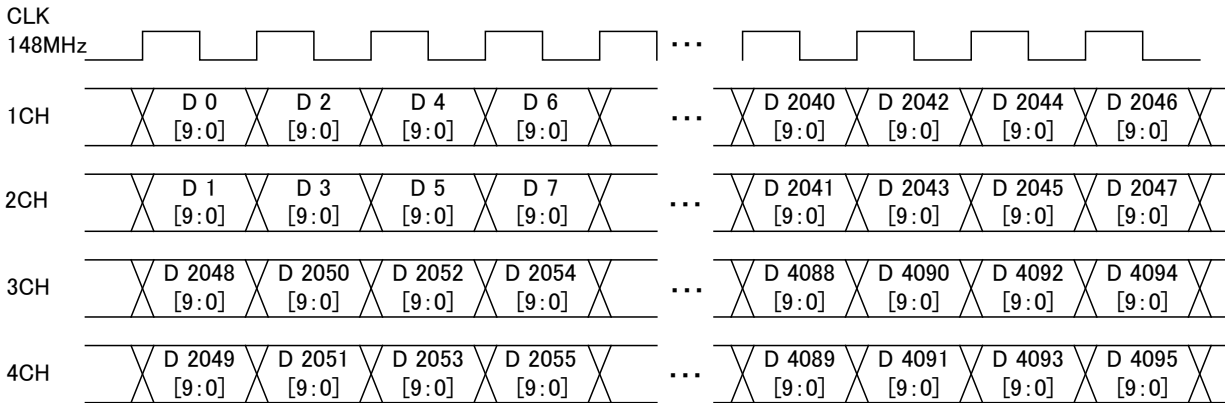

[5] MODE4 (Quad Link) (no dividing)

Using channel 1 and 2, EVEN pixels are output. Using channel 3 and 4, ODD pixels are output.

Given here as an example of the resolution is 4096 × 2048, the dot clock frequency is 592 MHz with the 10 bits output.

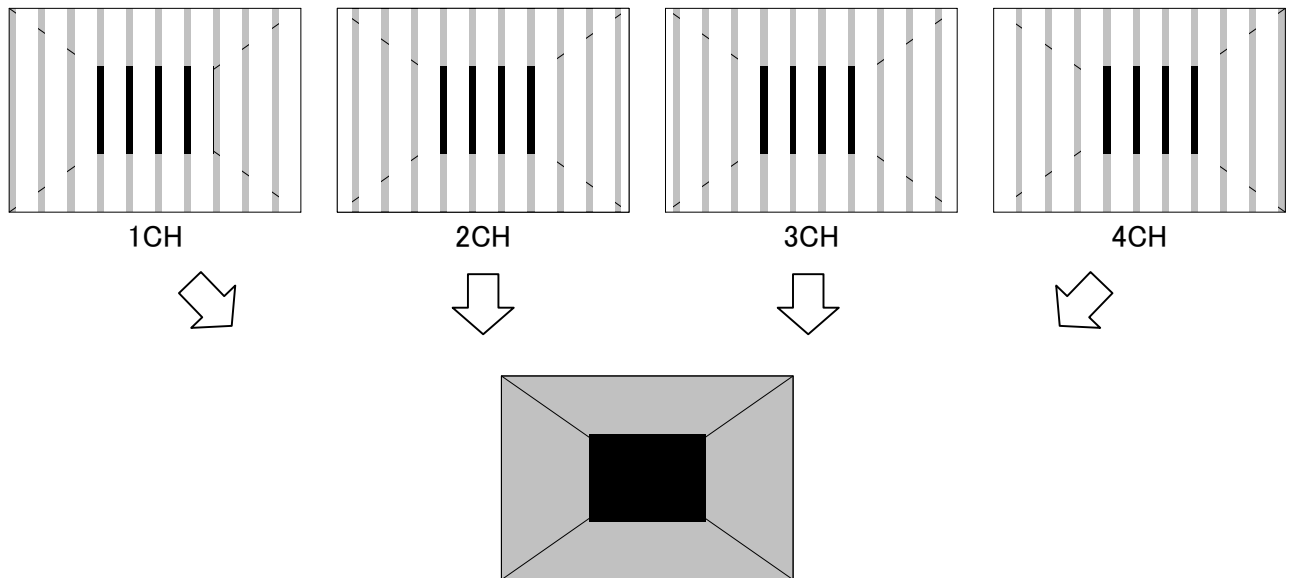
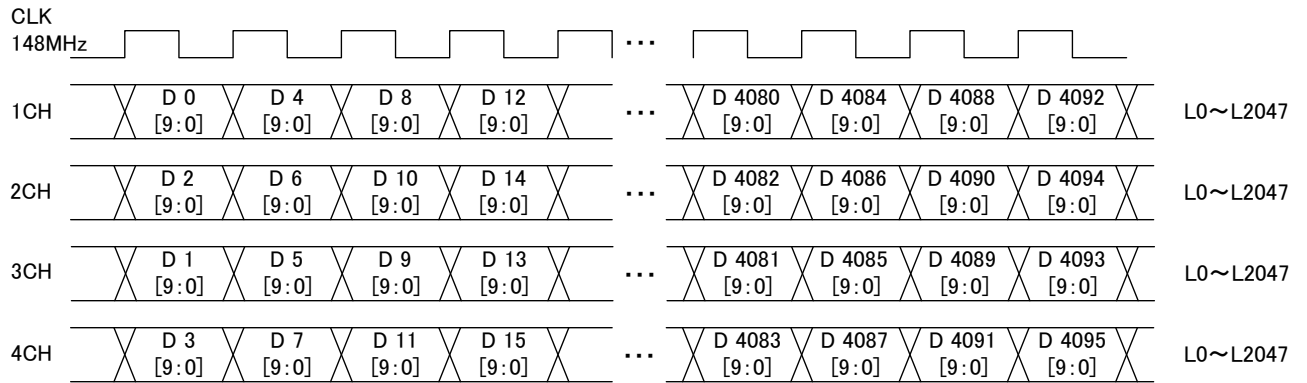

Specifications for modes during x4 mode (Full HD 240 Hz mode) output

The x4 mode is an output mode designed for the inspection of the FPD which support the Full HD 240 Hz output. By connecting the output of the VG generator to the IA-1540 (iTMSD-LVDS converter box), the signal becomes 1/2 and output in 8 channels.

The below explanation concerns the signals of 4 channels output from the VG generator. For an explanation about an 8-channel output from LVDS, refer to section "4.13.3 Data transfer systems (V-By-One HS)."

4.13.3

- * As shown in the figure below, the data of channels 1 to 4 for the Master and Slave of Dual Link of VM-1824 is described in this section.
- * Also described below in this section is the Single Link data of the VM-1824-A which is output as the data of channels 1 to 4.

[Full HD 240 Hz output]

[VG generator iTMSD 4-channel output]

[IA converter box 8-channel output]

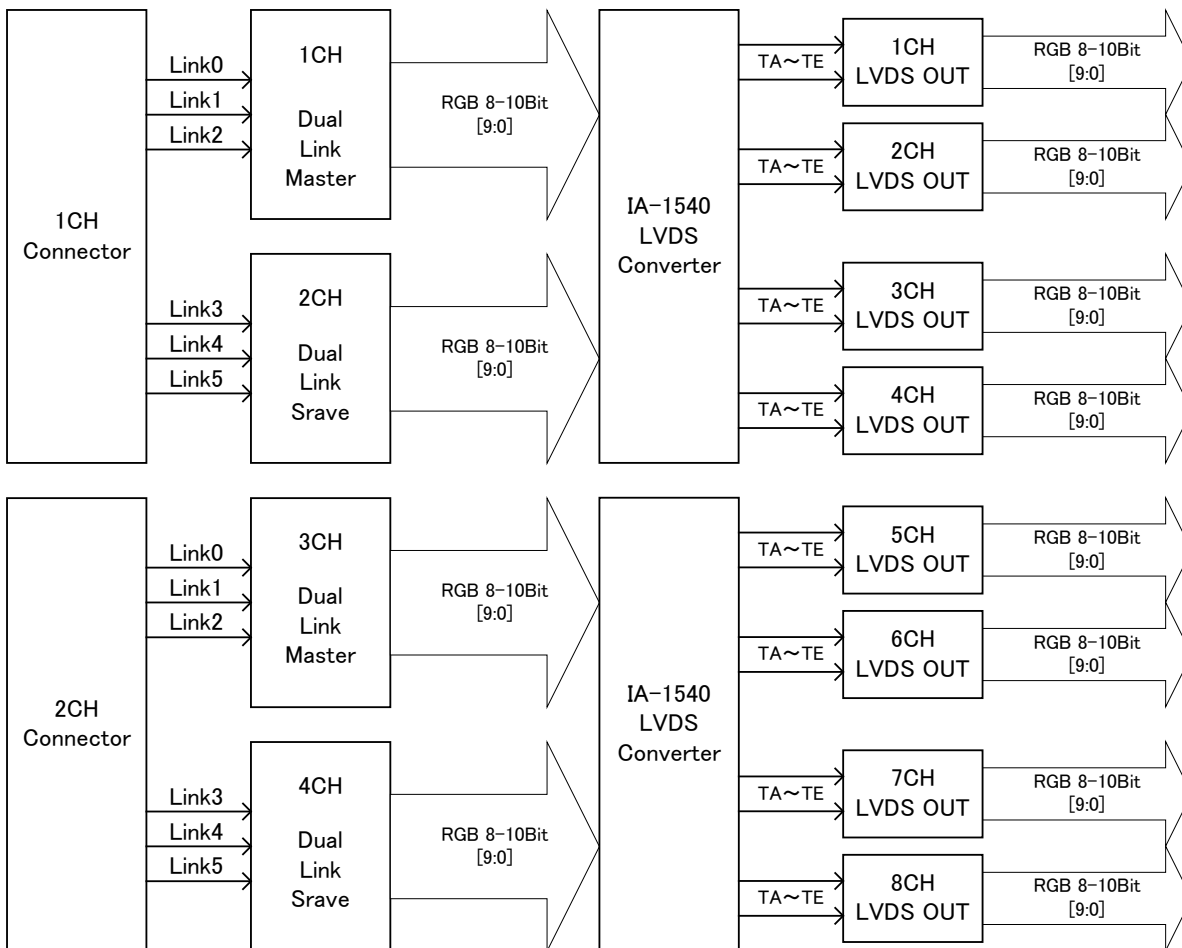

[1] MODE0 x4 Mode (Quad Link) (Non Dividing Mode)

Using channels 1, 2, 3 and 4, the image is output under the pixel assignment given below without splitting the screen.

Given here as an example of the resolution is 1920 x 1080, the dot clock frequency is 592 MHz with the 10 bits output.

The x4 mode is an output mode designed for the inspection of FPD which support the Full HD 240 Hz output. By connecting the output of the VG generator to the IA-1540 (iTMD5-LVDS converter box) and by halving the output in the converter box,

The explanation concerns the signals of the four channels output from the VG generator. For an explanation concerning an 8-channel output from LVDS, refer to section "4.13.3 Data transfer systems (V-By-One HS)."

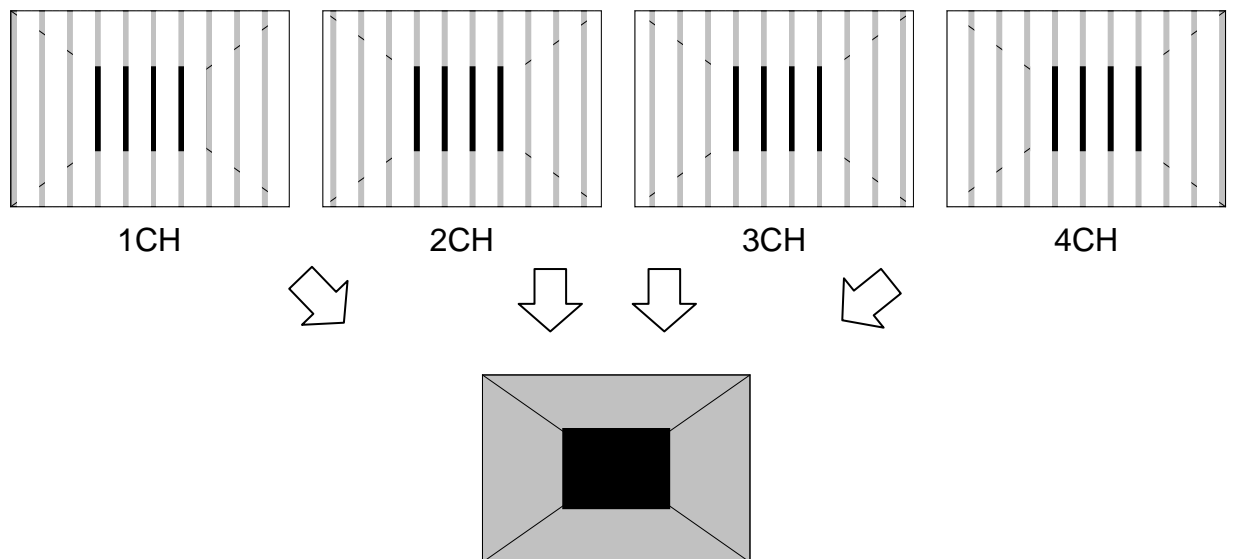
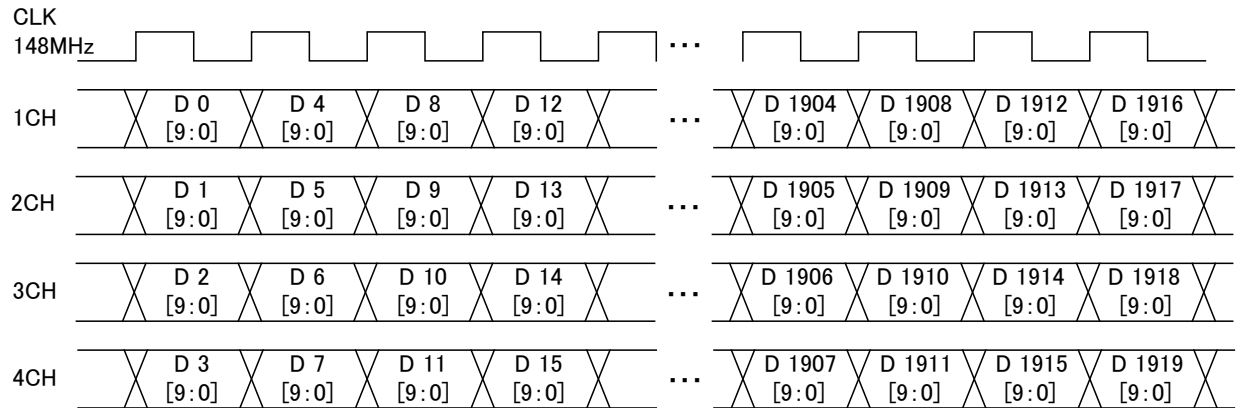

[2] MODE1 x4 Mode (Quad Link) (Normal Mode)

Using channels 1, 2, 3 and 4, the image is output under the pixel assignment given below without splitting the screen.

Given here as an example of the resolution is 1920 x 1080, the dot clock frequency is 592 MHz with the 10 bits output.

The x4 mode is an output mode designed for the inspection of FPD which support the Full HD 240 Hz output. By connecting the output of the VG generator to the IA-1540 (iTMDs-LVDS converter box) and by halving the output in the converter box,

The explanation concerns the signals of the four channels output from the VG generator. For an explanation concerning an 8-channel output from LVDS, refer to section "4.13.3 Data transfer systems (V-By-One HS)."

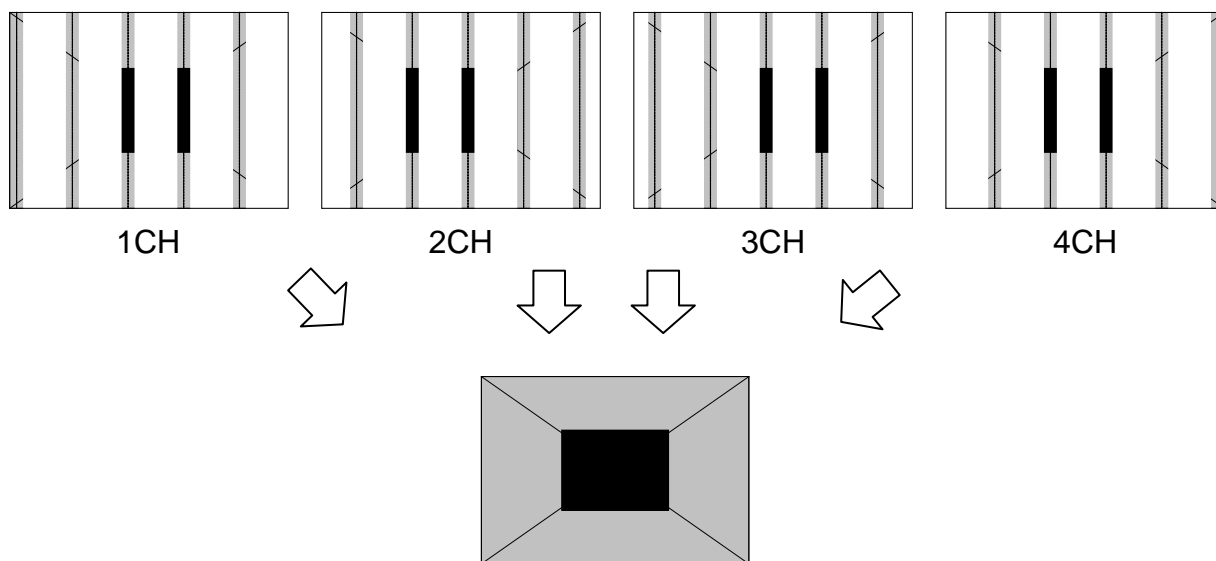
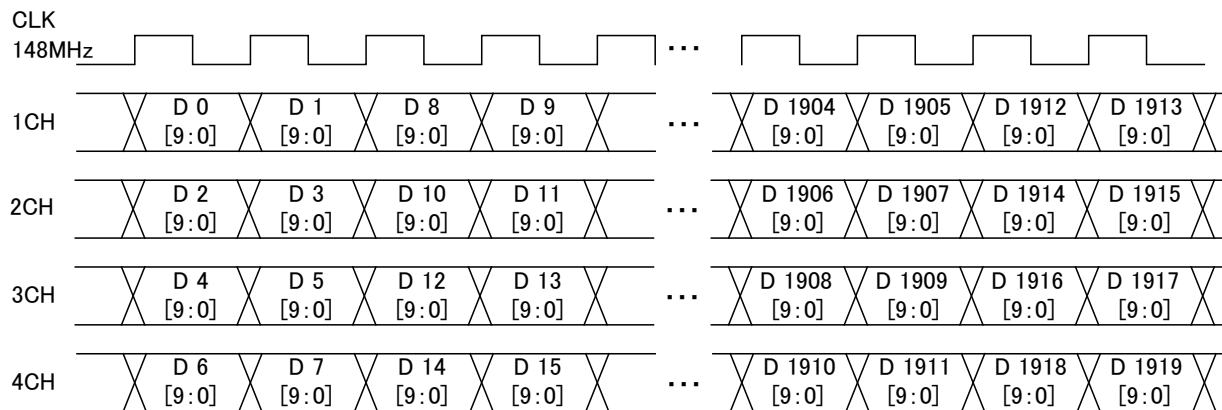

[3] MODE2 x4 Mode (Quad Link) (Cross Mode)

Using channels 1, 2, 3 and 4, the image is output under the pixel assignment given below without splitting the screen.

Given here as an example of the resolution is 1920 x 1080, the dot clock frequency is 592 MHz with the 10 bits output.

The x4 mode is an output mode designed for the inspection of FPD which support the Full HD 240 Hz output. By connecting the output of the VG generator to the IA-1540 (iTMDs-LVDS converter box) and by halving the output in the converter box,

The explanation concerns the signals of the four channels output from the VG generator. For an explanation concerning an 8-channel output from LVDS, refer to section "4.13.3 Data transfer systems (V-By-One HS)."

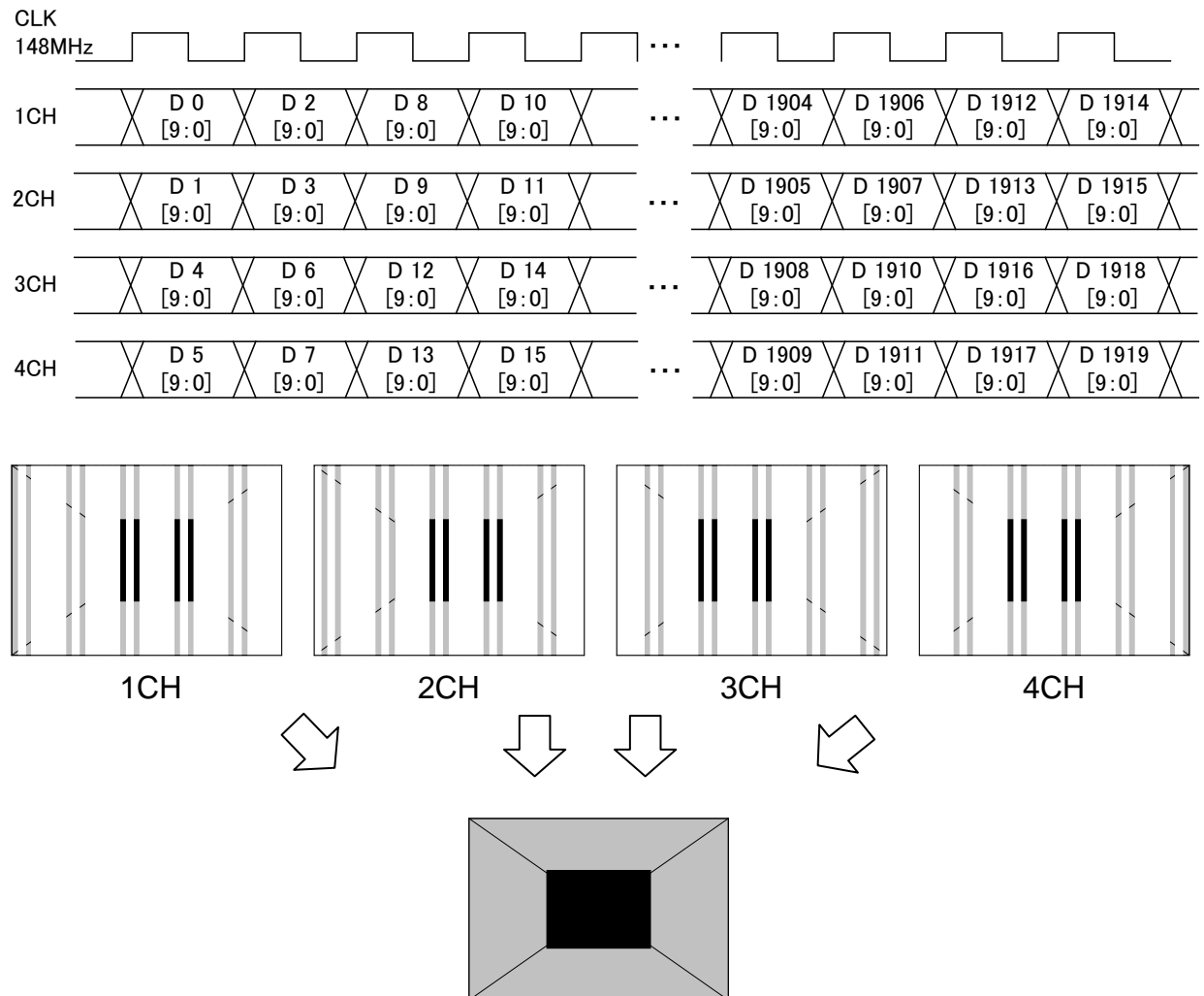

[4] MODE3 x4 Mode (Quad Link) (Dividing Normal Mode)

Using channels 1 and 2, the right half of the image is output; similarly, using channels 3 and 4, the left half of the image is output. The pixel assignment is given below.

Given here as an example of the resolution is 1920 × 1080, the dot clock frequency is 592 MHz with the 10 bits output.

The x4 mode is an output mode designed for the inspection of FPD which support the Full HD 240 Hz output. By connecting the output of the VG generator to the IA-1540 (iTMDs-LVDS converter box) and by halving the output in the converter box,

The explanation concerns the signals of the four channels output from the VG generator. For an explanation concerning an 8-channel output from LVDS, refer to section "4.13.3 Data transfer systems (V-By-One HS)."

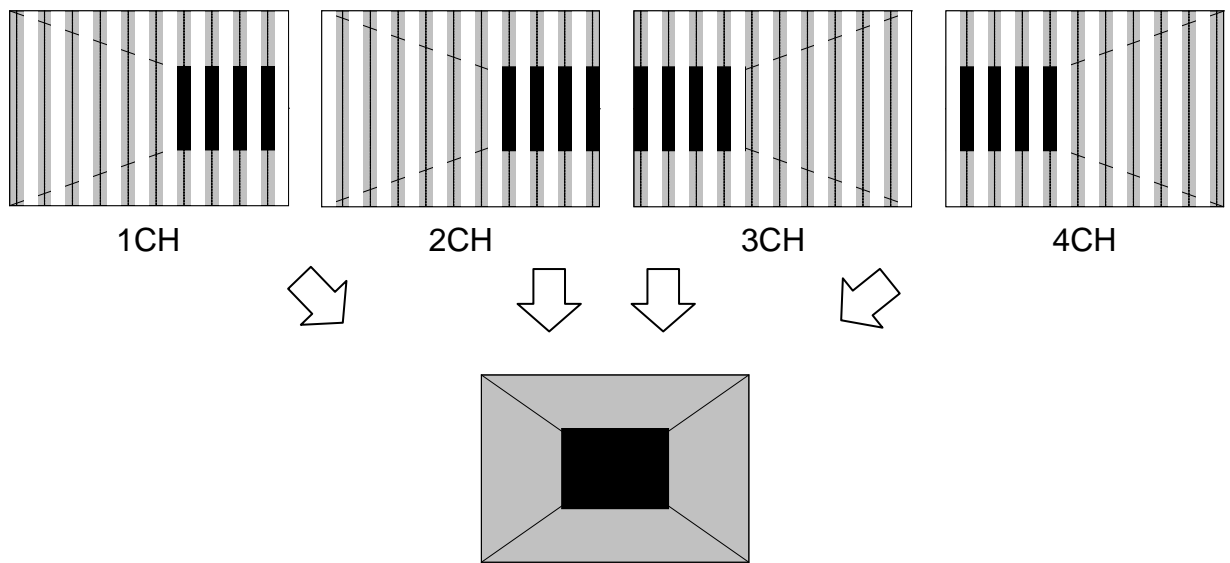
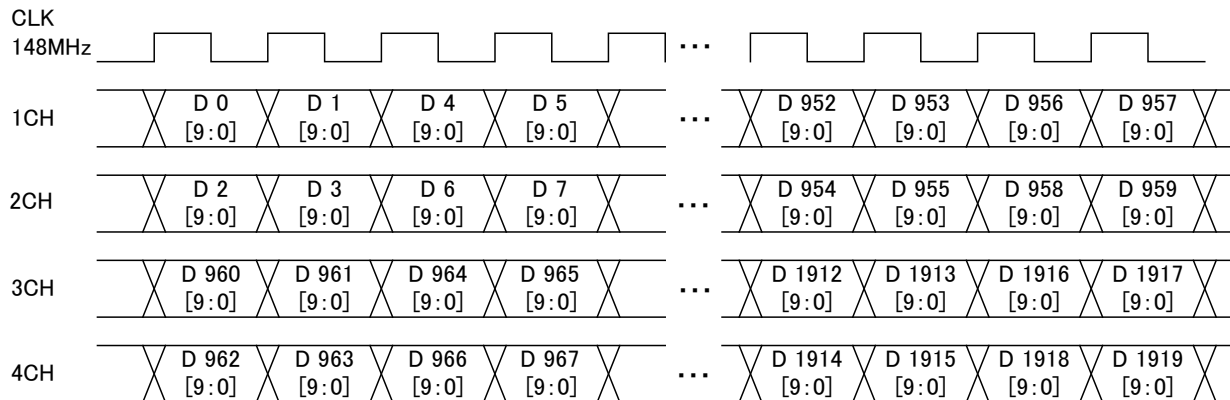

[5] MODE4 x4 Mode (Quad Link) (Dividing Cross Mode)

Using channels 1 and 2, the right half of the image is output; similarly, using channels 3 and 4, the left half of the image is output. The pixel assignment is given below.

Given here as an example of the resolution is 1920 × 1080, the dot clock frequency is 592 MHz with the 10 bits output.

The x4 mode is an output mode designed for the inspection of flat panel devices which support the Full HD 240 Hz output. By connecting the output of the VG generator to the IA-1540 (iTMDs-LVDS converter box) and by halving the output in the converter box,

The explanation concerns the signals of the four channels output from the VG generator. For an explanation concerning an 8-channel output from LVDS, refer to section "4.13.3 Data transfer systems (V-By-One HS)."

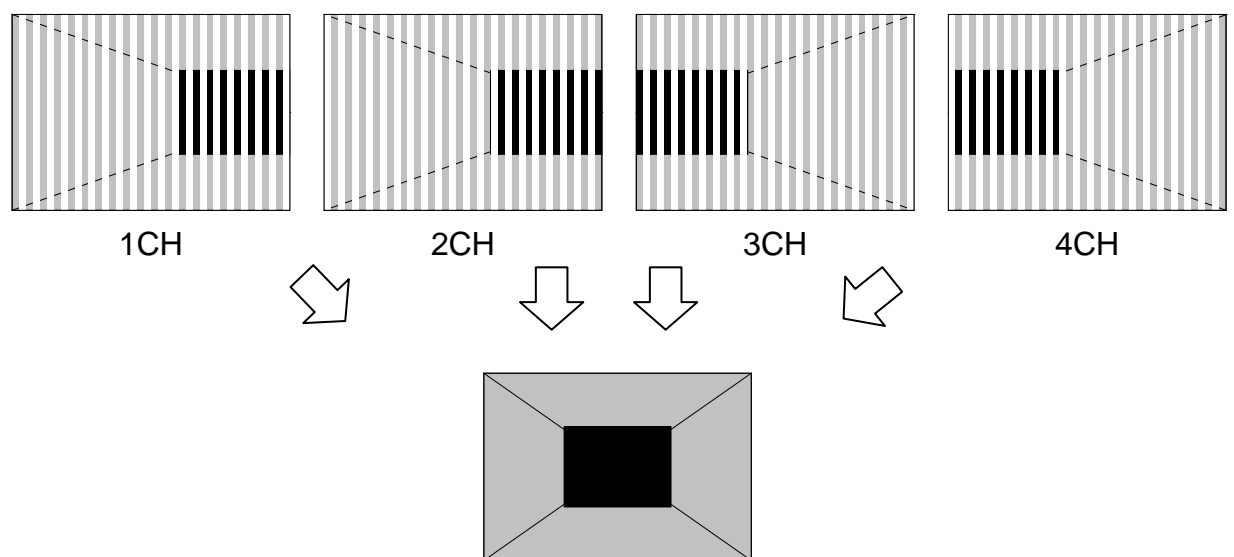
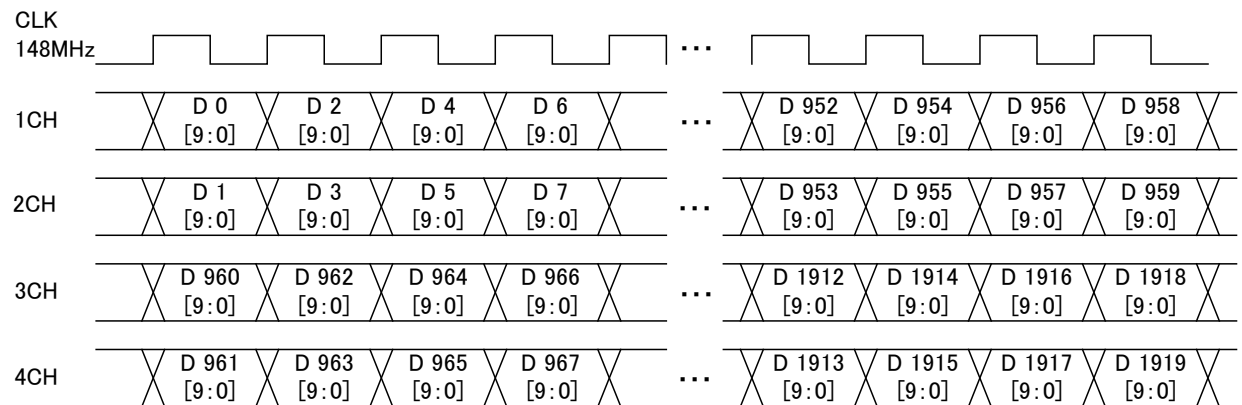

Specifications for Octal Link modes during 4Kx2K with 2-board mode (4Kx2K 120 Hz mode) output

This mode is an output mode designed for 4Kx2K 120 Hz inspections.

During the 4Kx2K 2-board mode output, Dual Link equivalent to four channels is used through the use of two output boards, and one screen is produced by combining the data of eight channels.

- * In the first VM-1824 board (lower slot), the data is output in channels 1 to 4 for the Master and Slave of Dual Link.
- * In the second VM-1824 board (upper slot), the data is output in channels 5 to 8 for the Master and Slave of Dual Link.
- * In the first VM-1824-A board (lower slot), the Single Link data is output as channels 1 to 4.
- * In the second VM-1824-A board (upper slot), the Single Link data is output as channels 5 to 8.

[4Kx2K 2-board 8-channel output]

[1st board output (lower slot)]

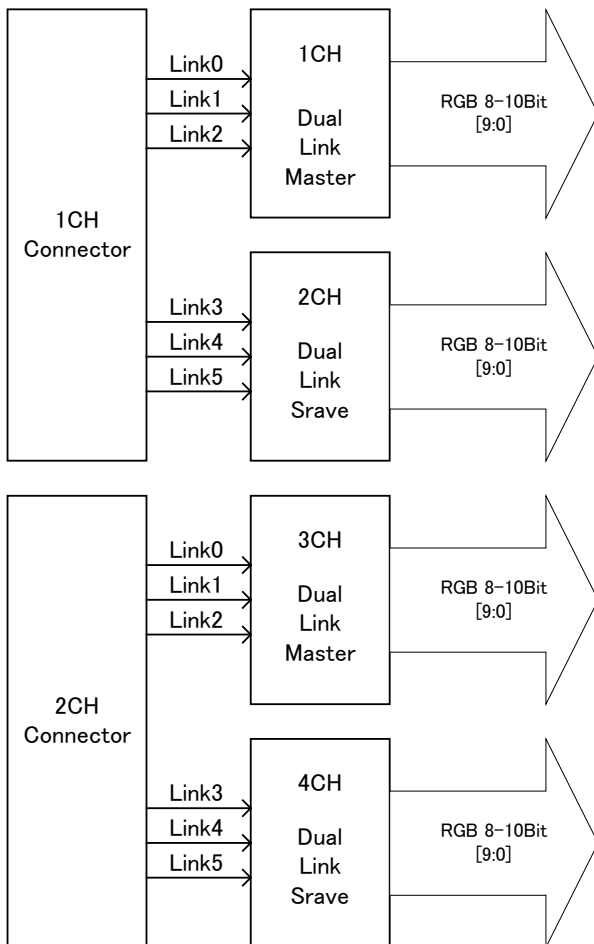

[2nd board output (upper slot)]

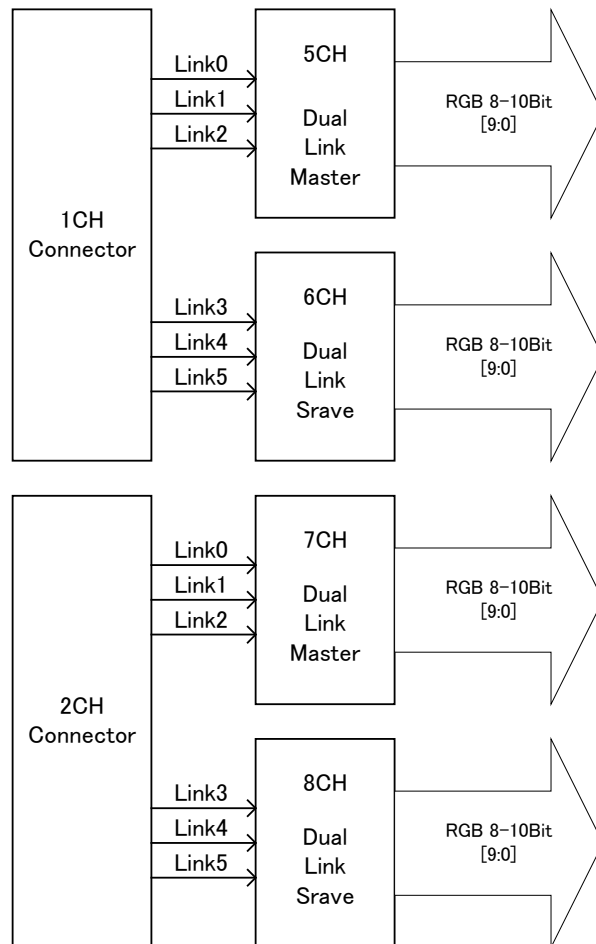

[1] MODE0 (Octal Link) (split into 4 equal square parts + split vertically into 2)

Channels 1 to 8 are used. The screen is split into 4 in the form of a square divided into 4 equal parts and output from each of the output boards, and then it is split vertically into two at each board, and output.

Given here as an example of the resolution is 4096 × 2048, the dot clock frequency is 1184 MHz with the 10 bits output.

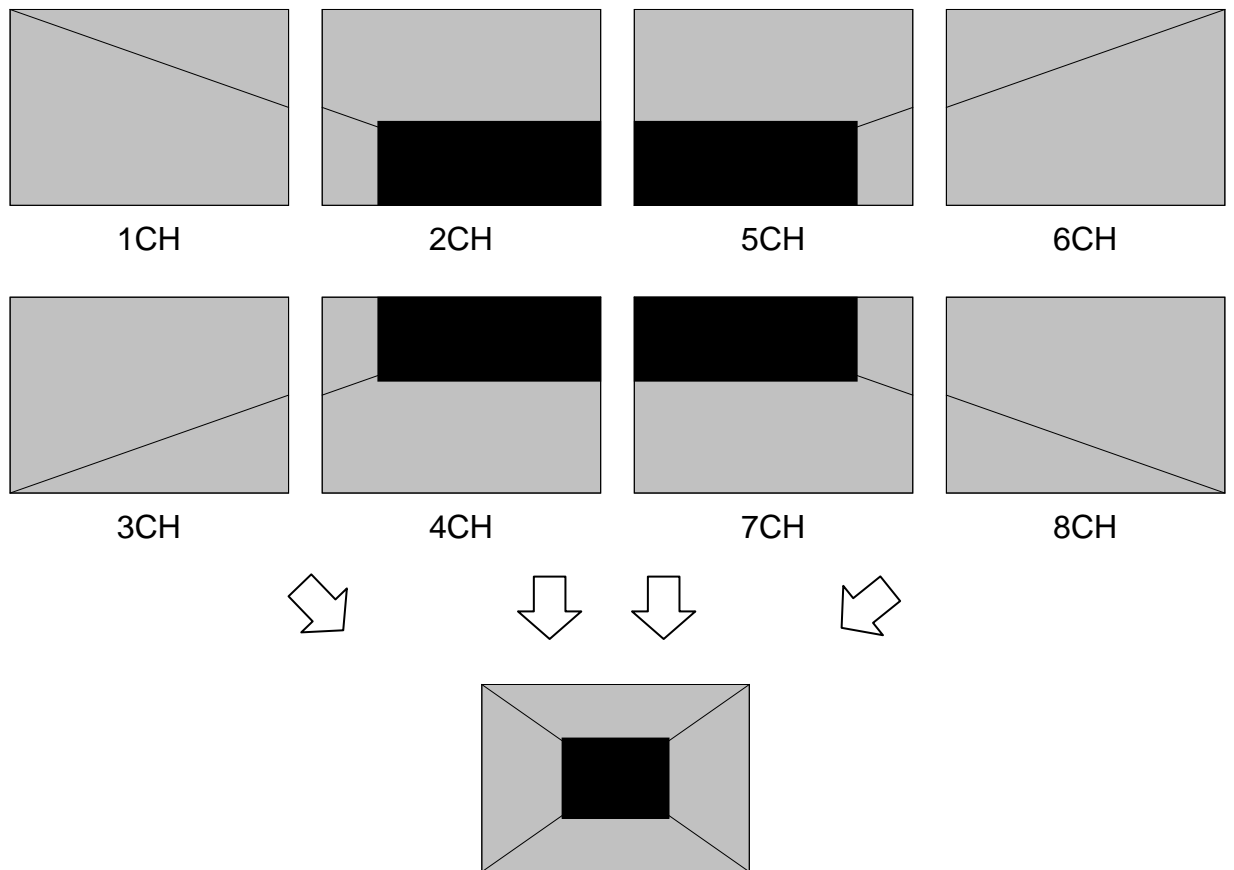
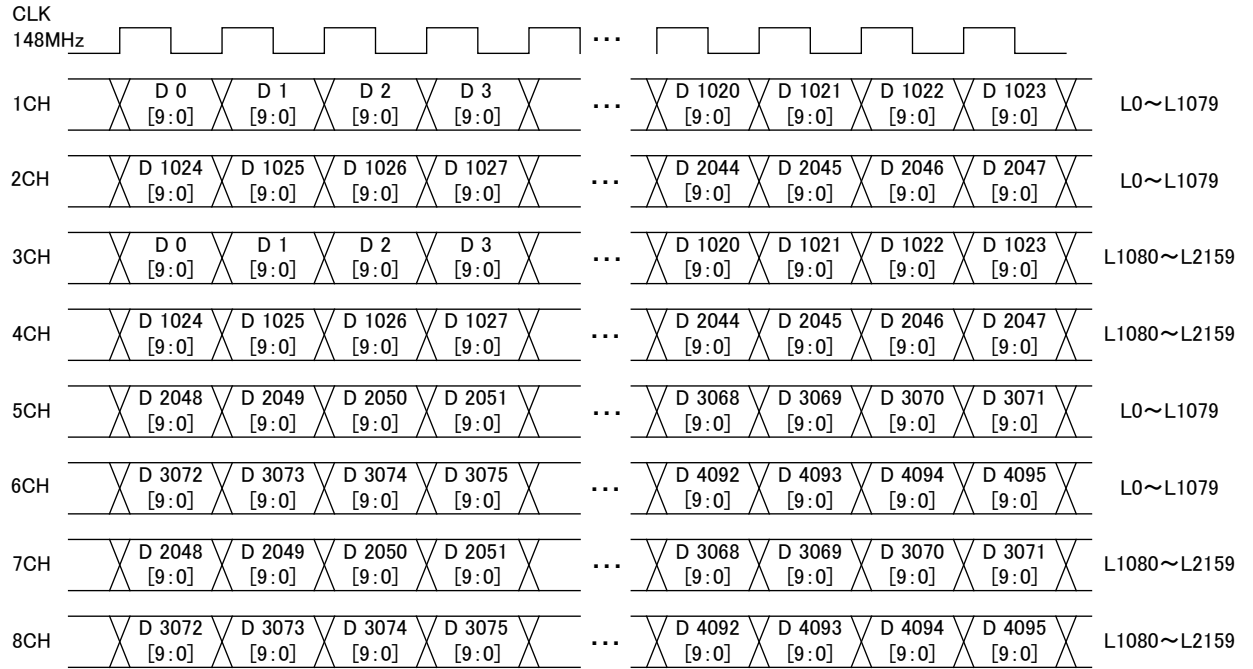

[2] MODE1 (Octal Link) (split vertically into 4 + split vertically into 2)

Channels 1 to 8 are used. The screen is split vertically into 4 and output from each of the output boards, and then it is split vertically into two at each board and output.

Given here as an example of the resolution is 4096 × 2048, the dot clock frequency is 1184 MHz with the 10 bits output.

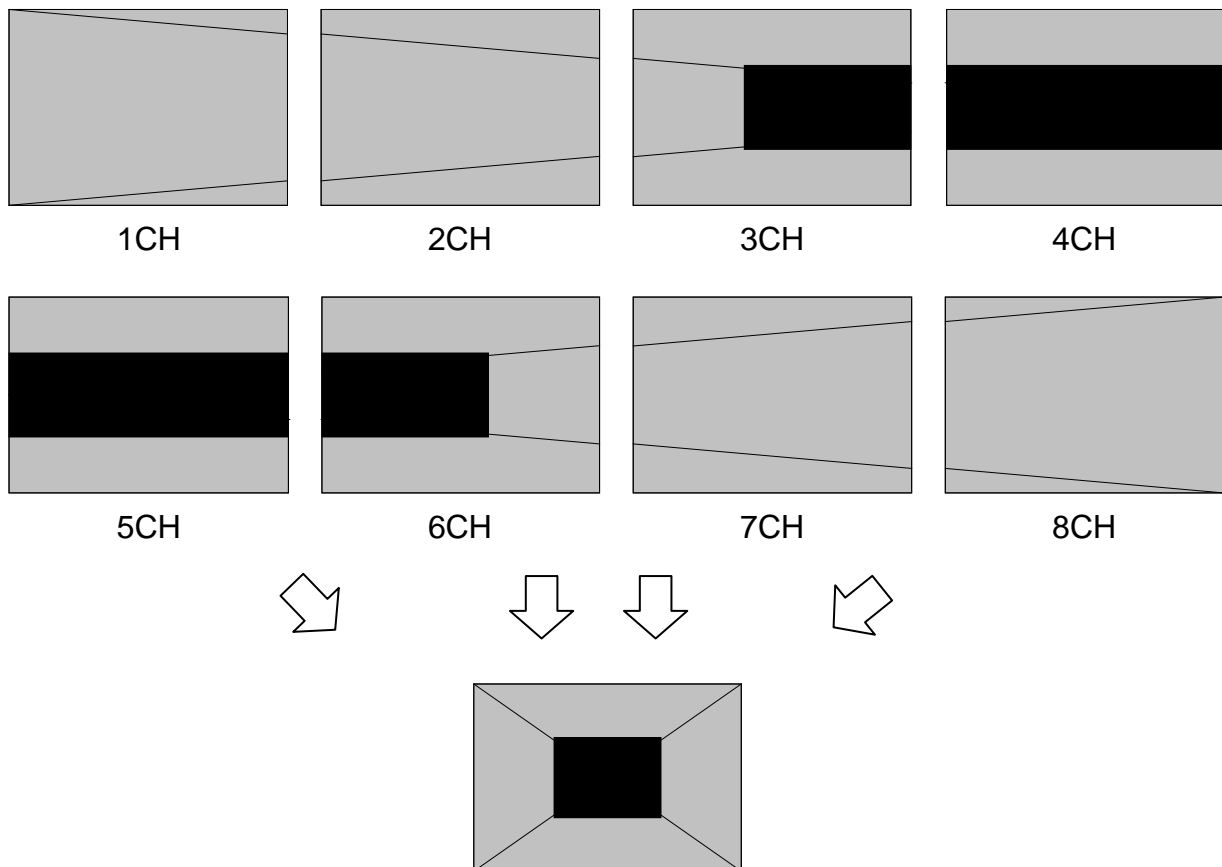
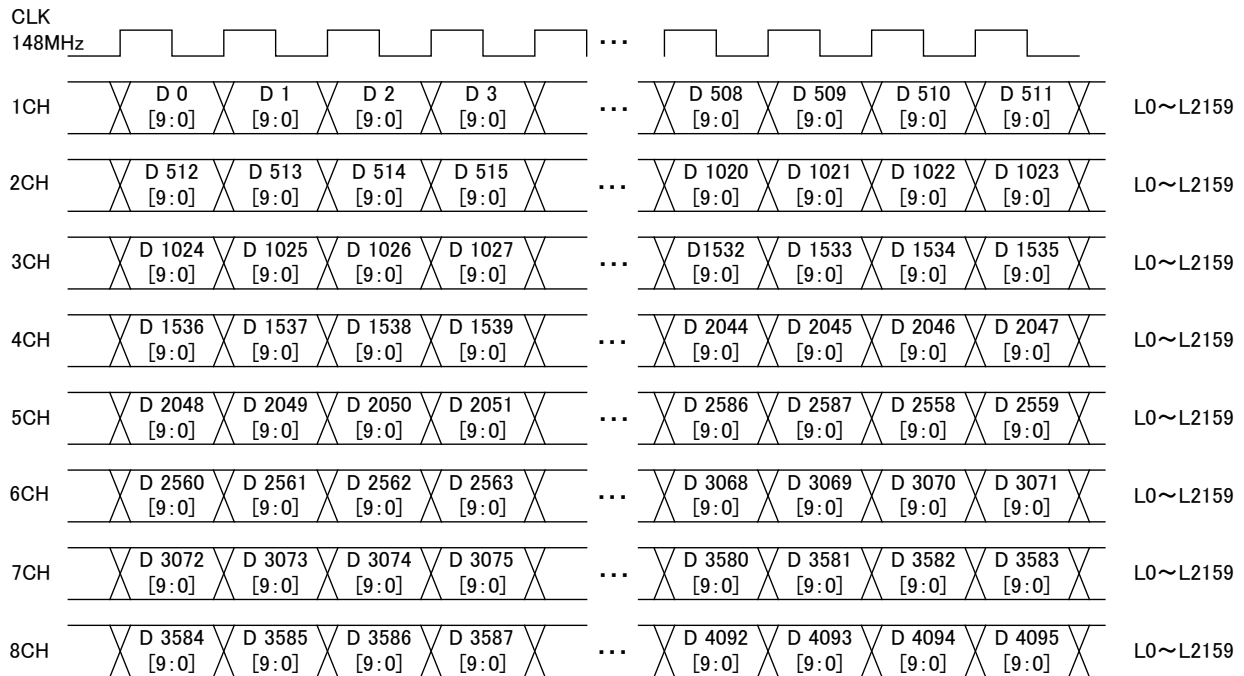

[3] MODE2 (Octal Link) (split horizontally into 2 + split vertically into 2)

Channels 1 to 8 are used. The screen is split horizontally into 2 and output from each of the output boards, and then it is split vertically into two at each board, and output.

Given here as an example of the resolution is 4096 x 2048, the dot clock frequency is 1184 MHz with the 10 bits output.

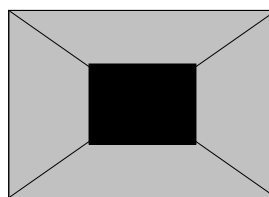
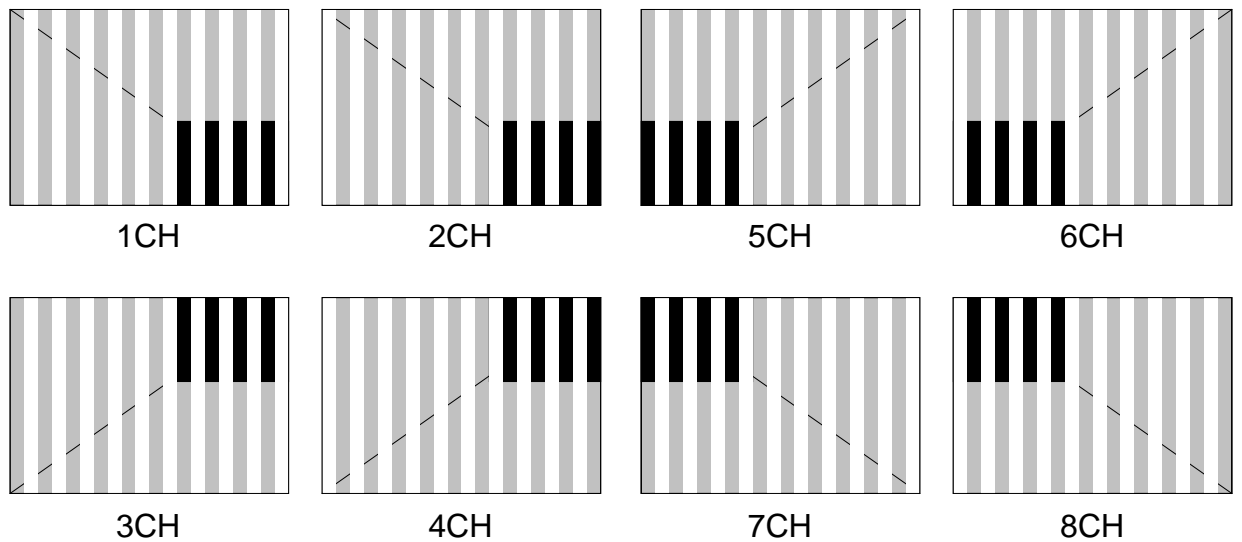
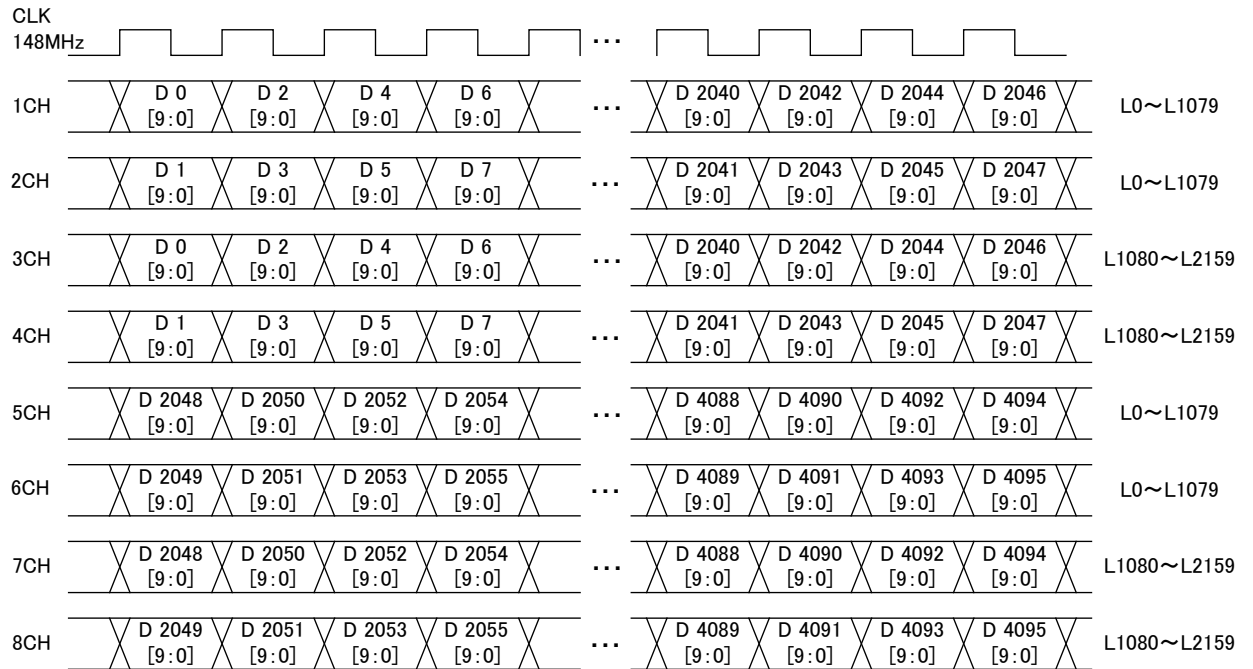

[4] MODE3 (Octal Link) (split vertically into 2 + split vertically into 2)

Channels 1 to 8 are used. The screen is split vertically into 2 and output from each of the output boards, and then it is split vertically into two at each board, and output.

Given here as an example of the resolution is 4096 × 2048, the dot clock frequency is 1184 MHz with the 10 bits output.

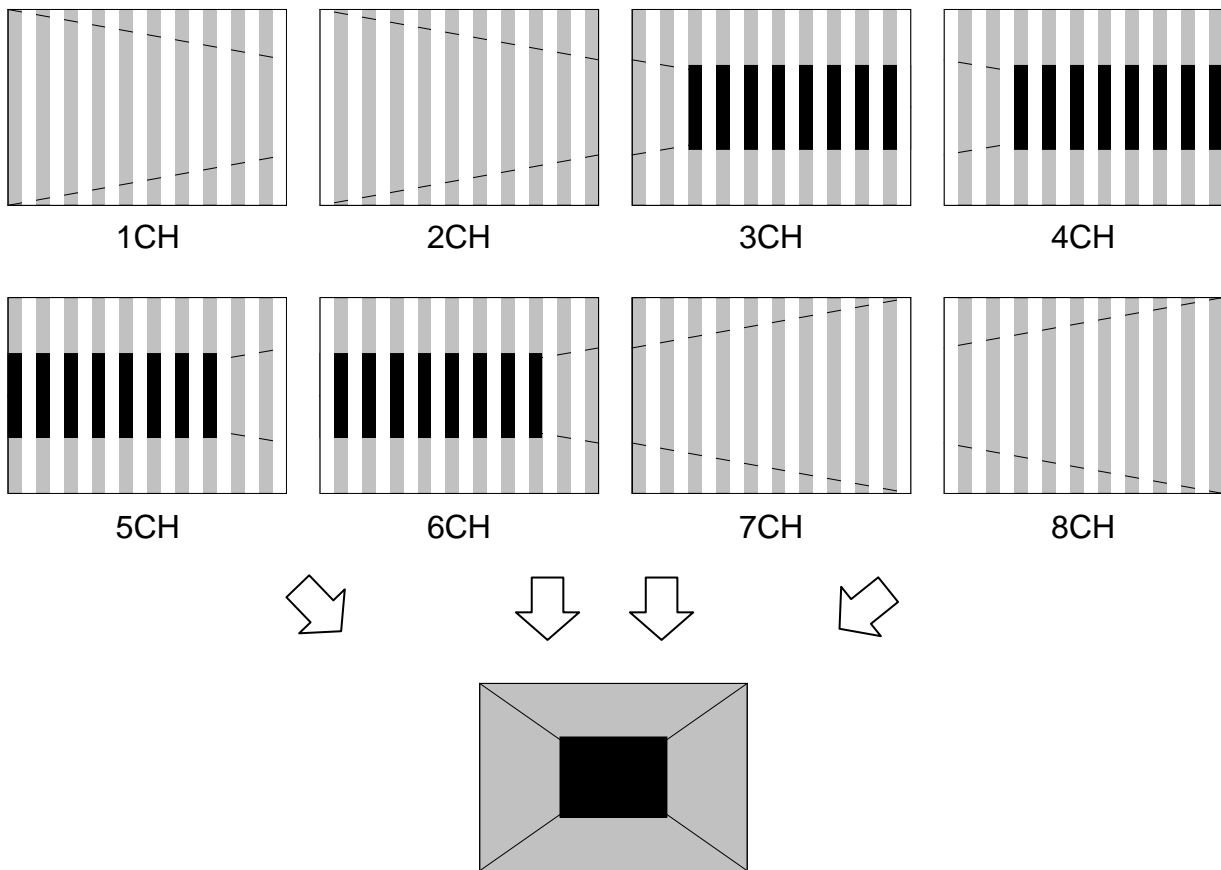
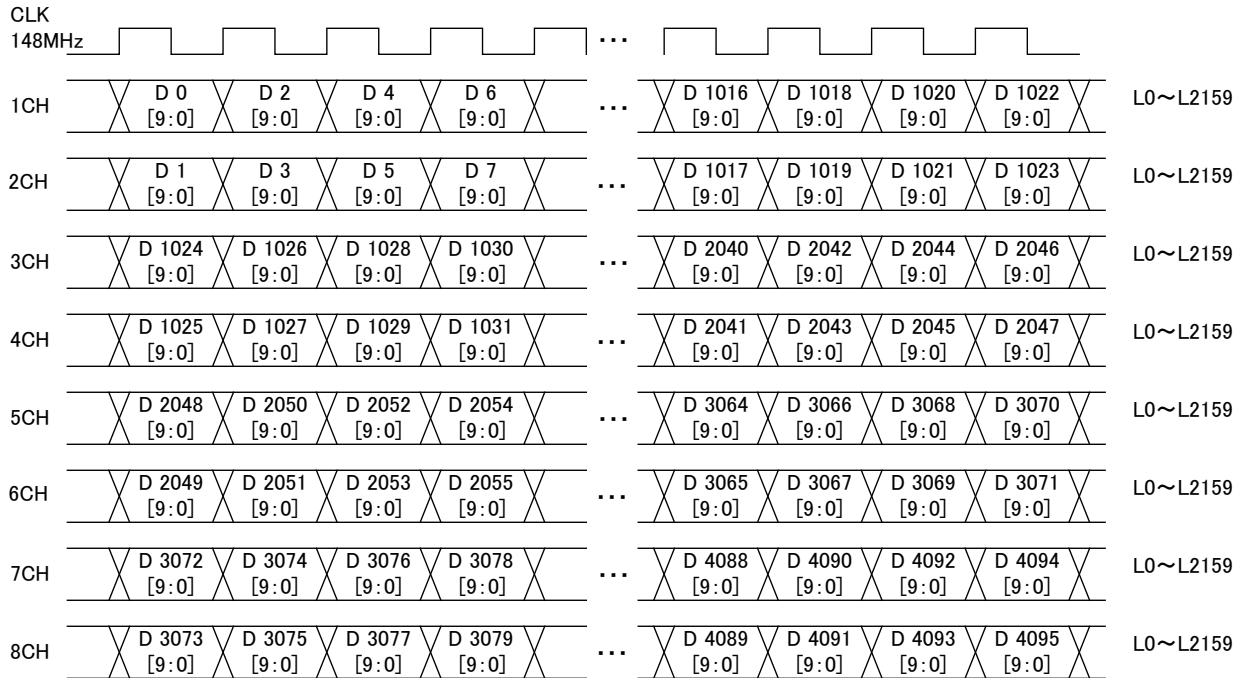

[5] MODE4 (Octal Link) (split vertically into 2 + no dividing in each board <1>)
(Non Dividing Mode)

Channels 1 to 8 are used. The screen is split vertically into 2 and output from each board. CH1-4 outputs the left half. CH5-8 outputs the right half with the below pixel assignment.

Given here as an example of the resolution is 4096 × 2048, the dot clock frequency is 1184 MHz with the 10 bits output.

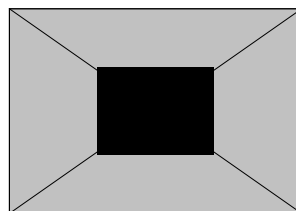
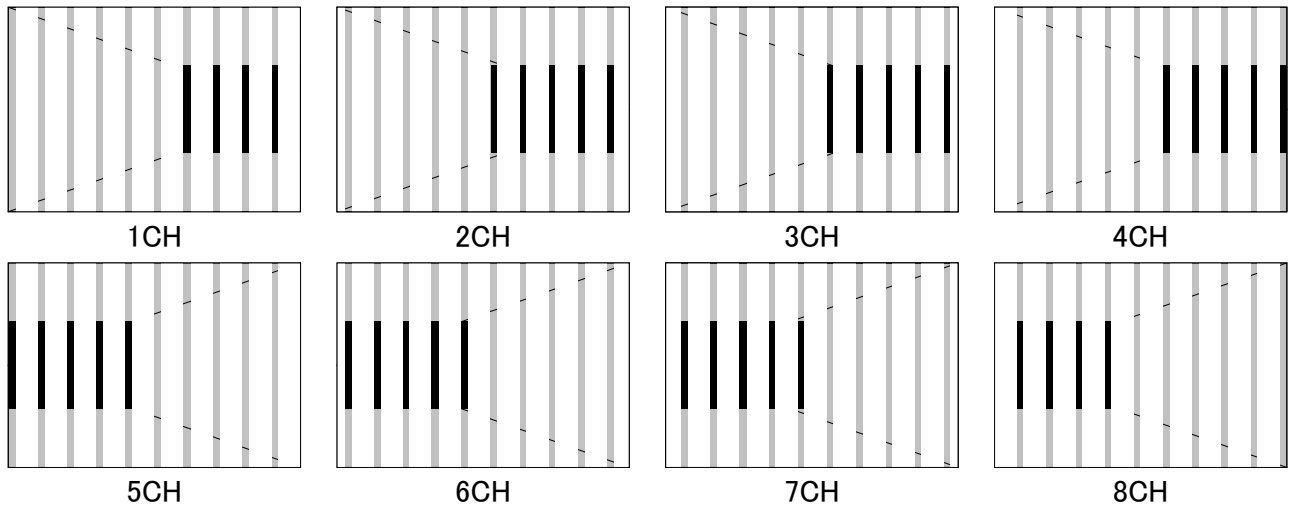
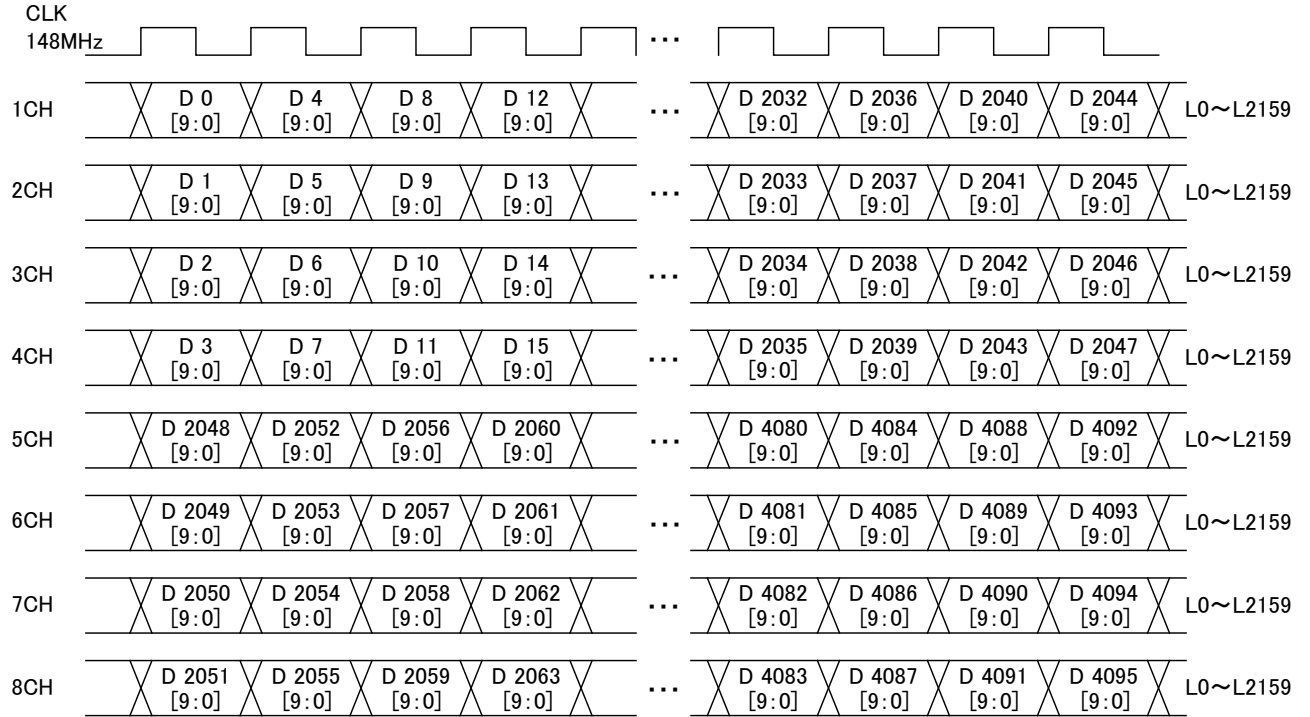

[6] MODE5 (Octal Link) (split vertically into 2 + no dividing in each board <2>)
(Normal Mode)

Channels 1 to 8 are used. The screen is split vertically into 2 and output from each board. CH1-4 outputs the left half. CH5-8 outputs the right half with the below pixel assignment.

Given here as an example of the resolution is 4096 x 2048, the dot clock frequency is 1184 MHz with the 10 bits output.

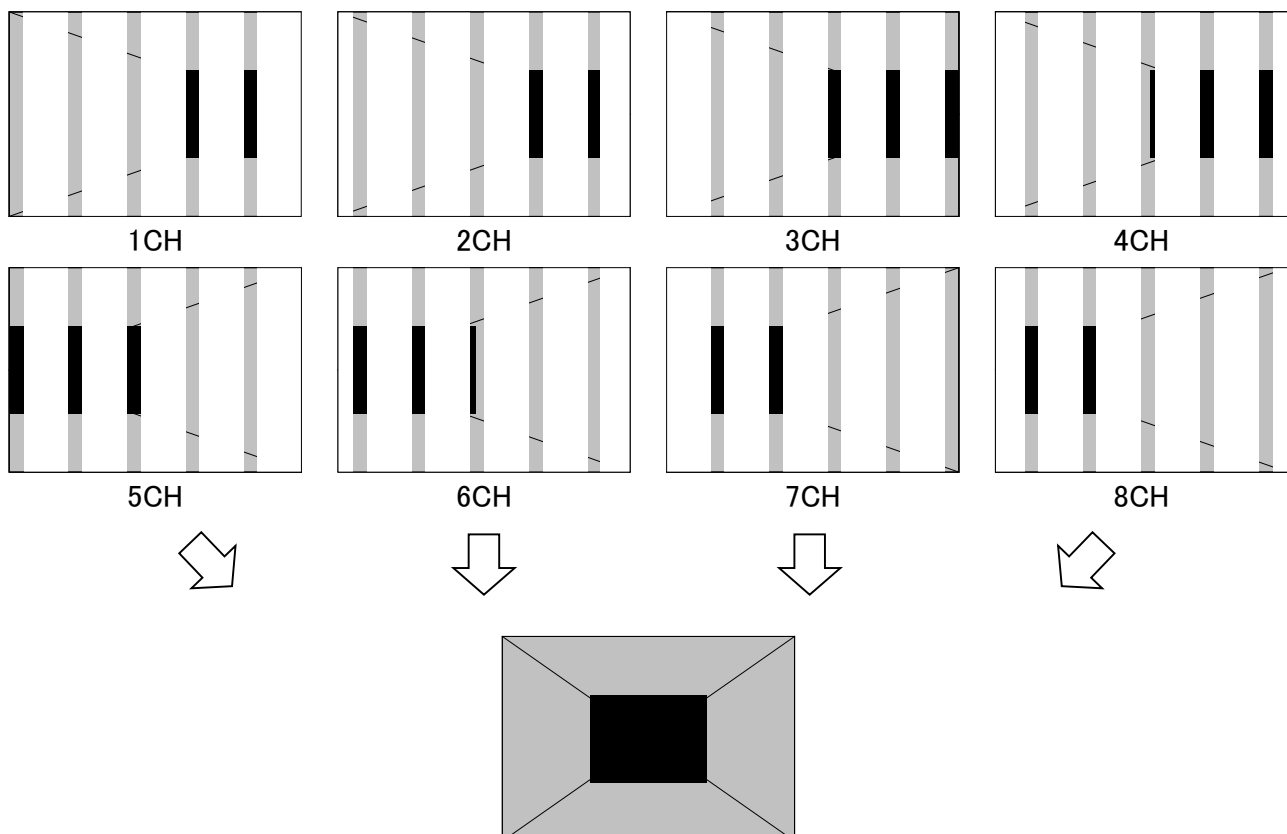
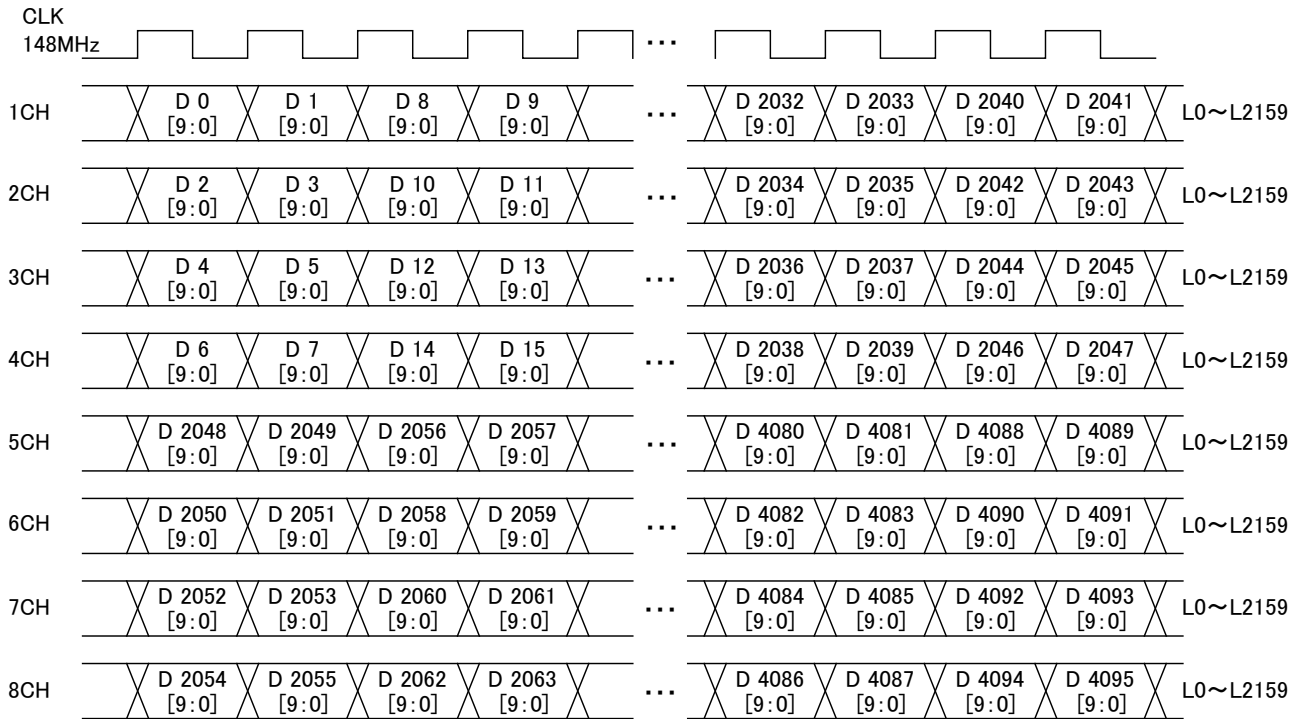

[7] MODE6 (Octal Link) (split vertically into 2 + no dividing in each board <3>)
(Cross Mode)

Channels 1 to 8 are used. The screen is split vertically into 2 and output from each board. CH1-4 outputs the left half. CH5-8 outputs the right half with the below pixel assignment.

Given here as an example of the resolution is 4096 x 2048, the dot clock frequency is 1184 MHz with the 10 bits output.

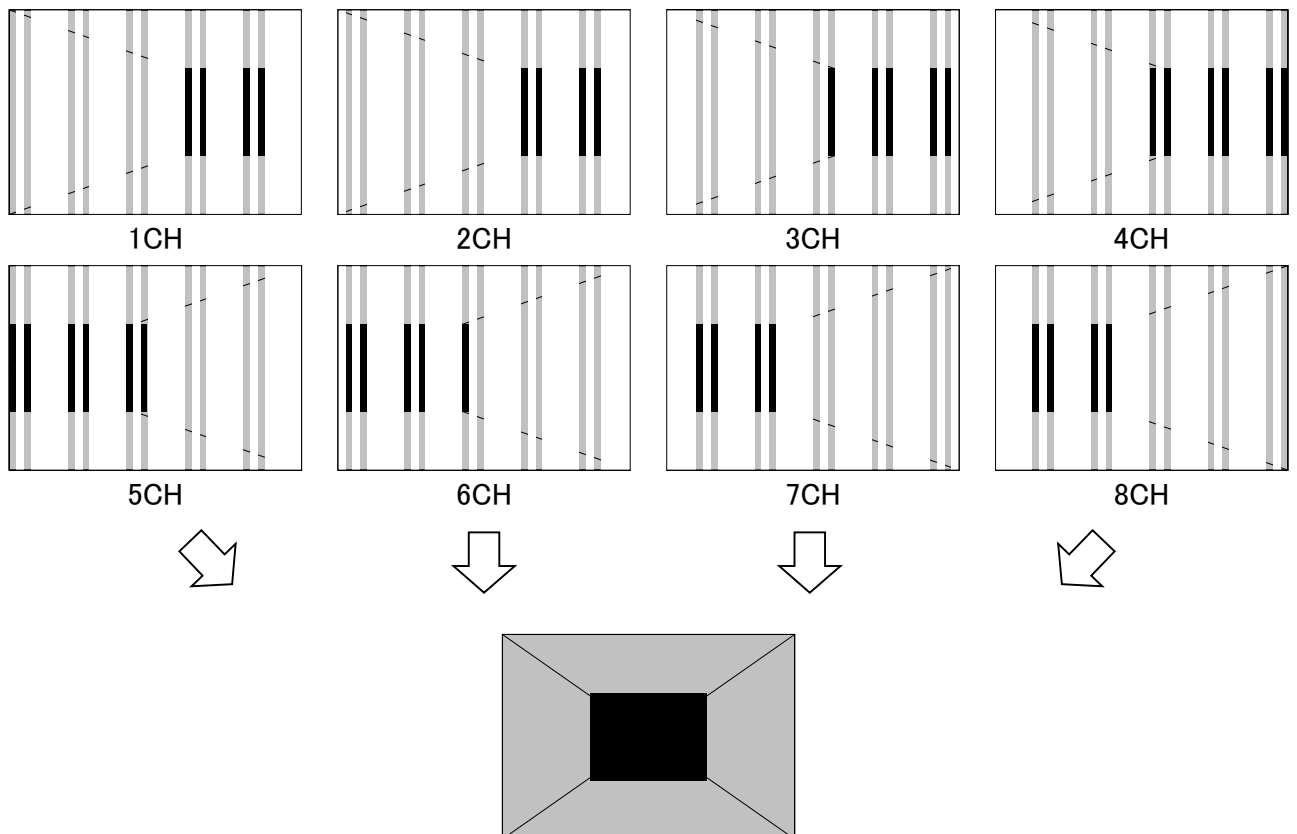
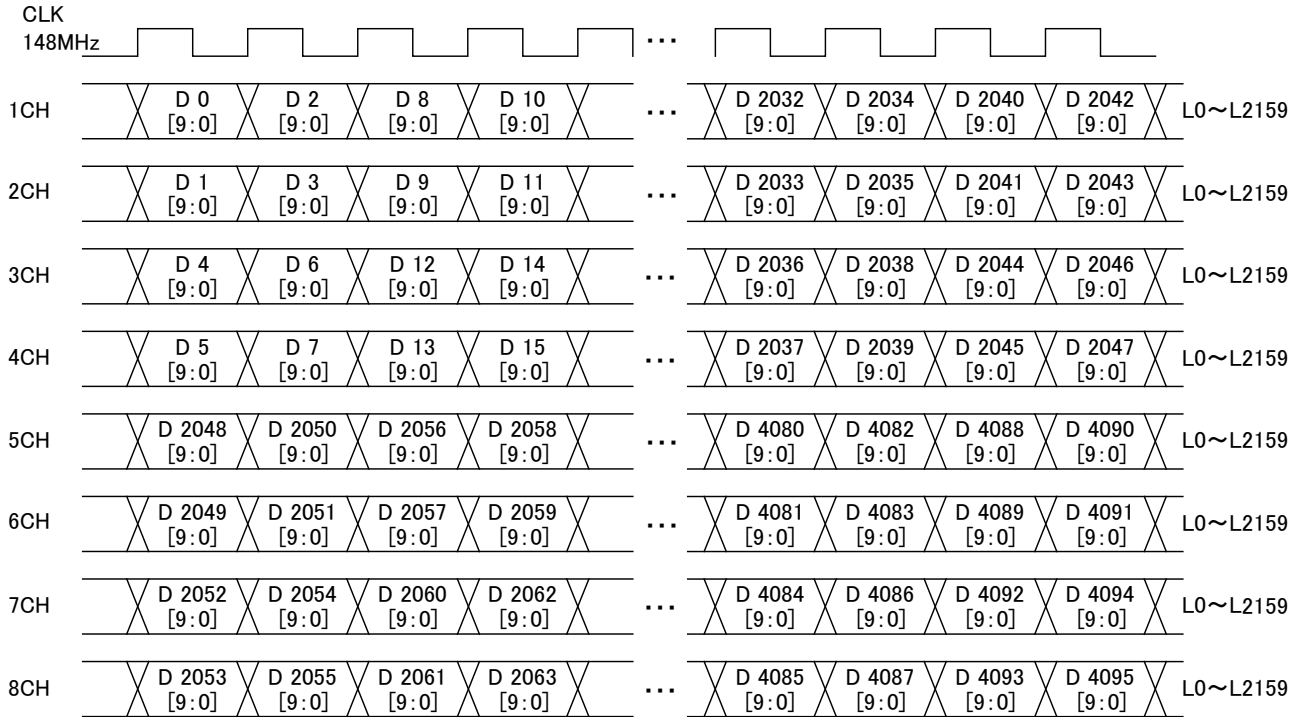

[8] MODE7 (Octal Link) (split vertically into 2 + dividing <1>)(Dividing Normal Mode)

Channels 1 to 8 are used. The screen is split vertically into 2 and output from each board. CH1-2 outputs 1/4 of the left side. CH3-4 outputs 1/4 of the left from the center. CH5-6 outputs 1/4 of the right from center. CH7-8 outputs 1/4 of right side with the below pixel assignment.

Given here as an example of the resolution is 4096 x 2048, the dot clock frequency is 1184 MHz with the 10 bits output.

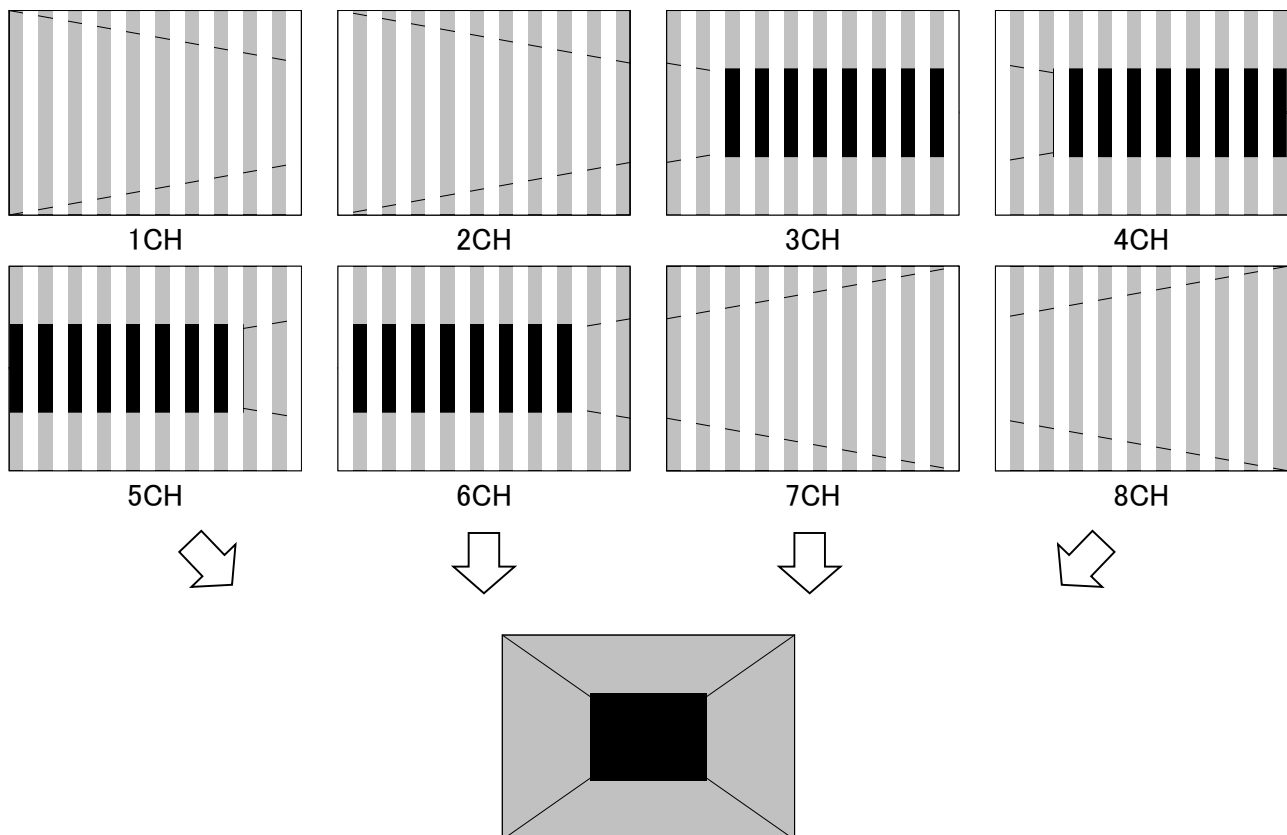
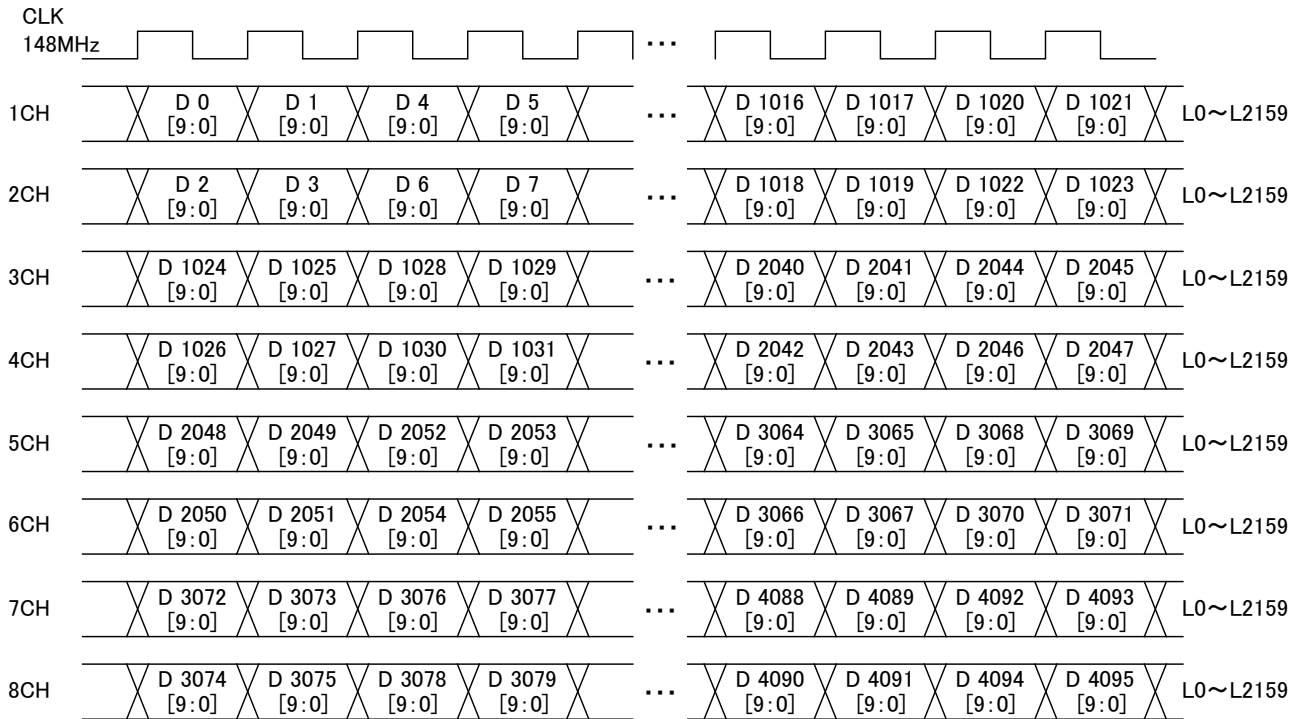

[9] MODE8 (Octal Link) (split vertically into 2 + dividing <2>)(Dividing Cross Mode)

Channels 1 to 8 are used. The screen is split vertically into 2 and output from each board. CH1-2 outputs 1/4 of the left side. CH3-4 outputs 1/4 of the left from the center. CH5-6 outputs 1/4 of the right from center. CH7-8 outputs 1/4 of right side with the below pixel assignment. Note This is same as Mode 3 (Octal Link)

Given here as an example of the resolution is 4096 × 2048, the dot clock frequency is 1184 MHz with the 10 bits output.

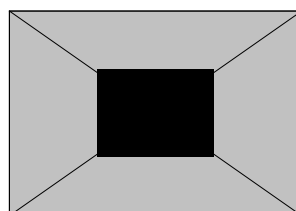
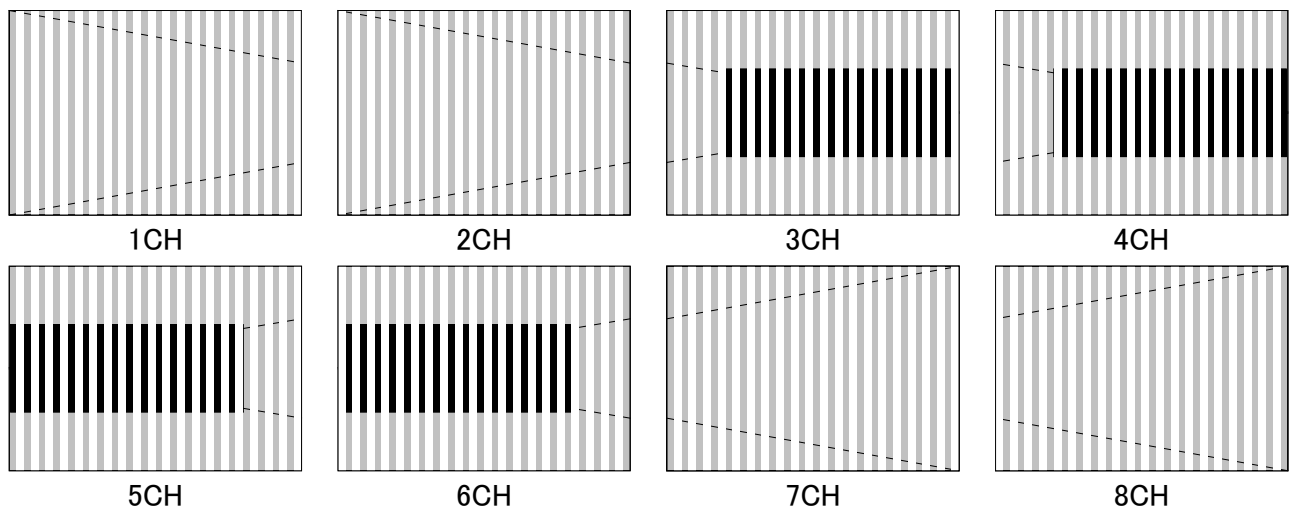
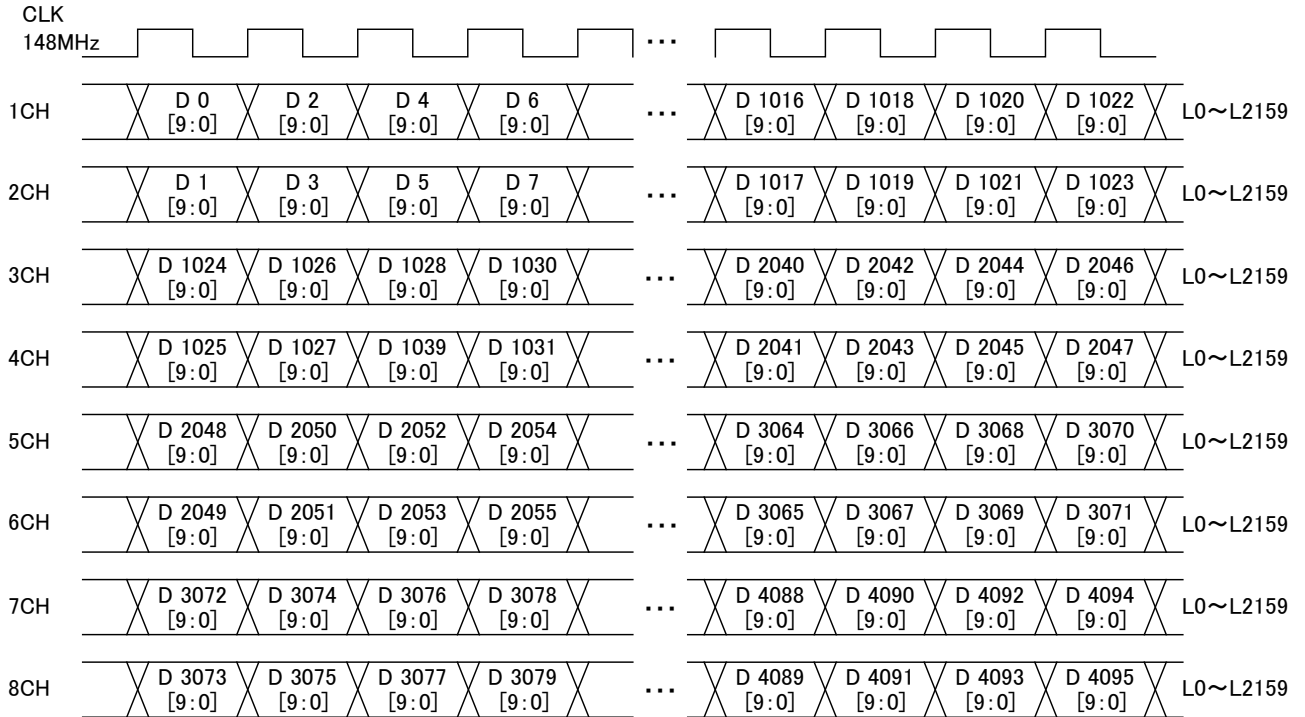

[10] MODE9 (Octal Link) (no split)

Channels 1 to 8 are used. The screen is not divided, and output by the below pixel assignment.

Given here as an example of the resolution is 4096 x 2048, the dot clock frequency is 1184 MHz with the 10 bits output.

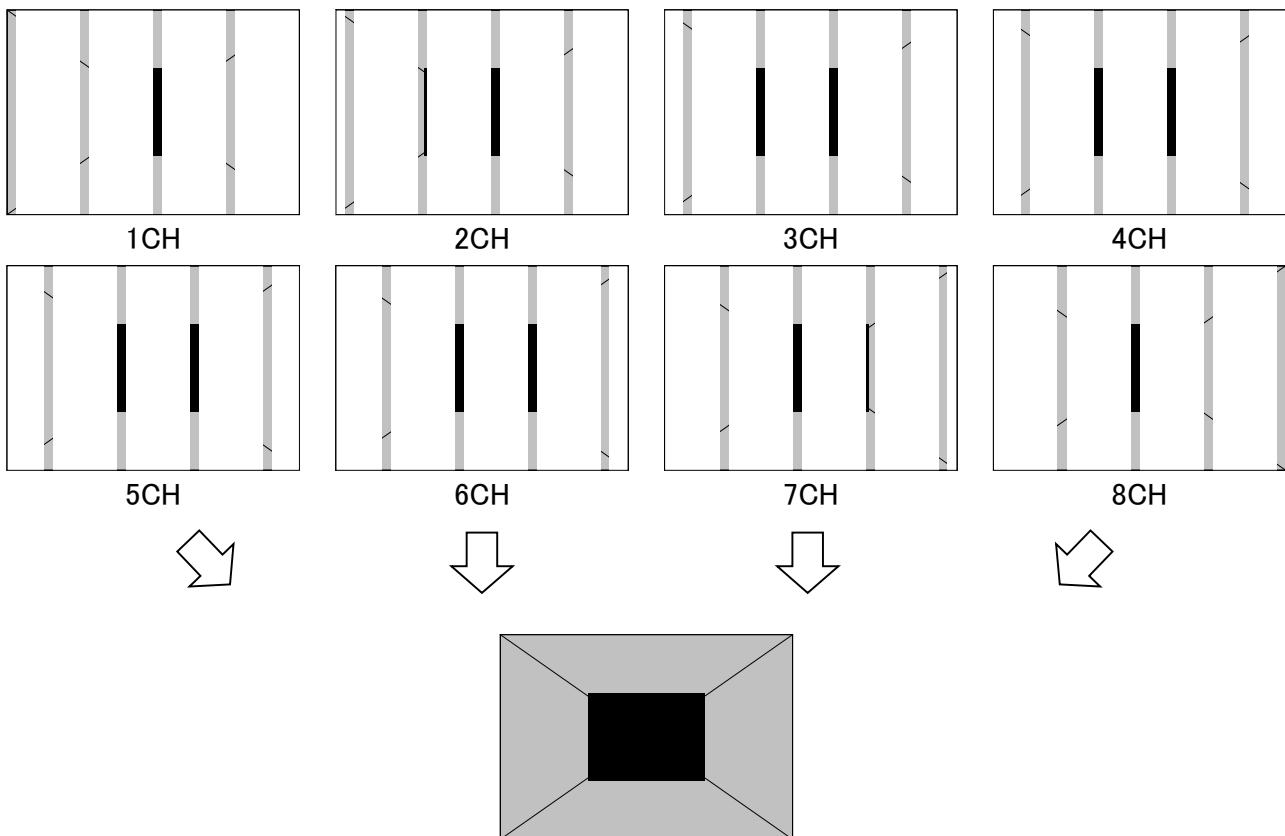
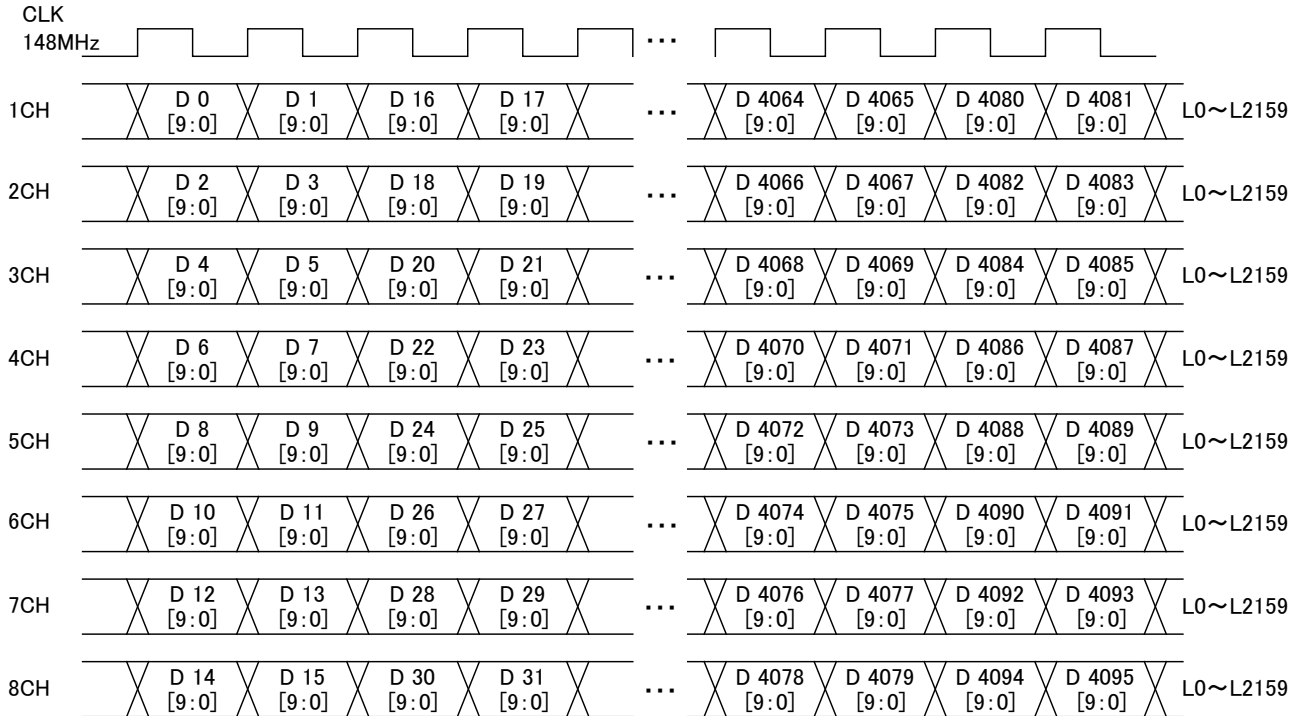

Specifications of bit assignment during 16-bit (8 + 8 bits) output

● DVI multiple bit output

Sixteen bits are output by using two DVI channels and outputting the data using 8 + 8 bits.

The higher 8 bits are allocated to one channel and the lower 8 bits to the other channel.

If the setting involves 15 or fewer bits, "0" is entered for the lower bits which will not be used.

● iTMDS multiple bit output

When outputting multiple bits using the iTMDS format, select iTMDS as the output setting.

When iTMDS has been selected, the multiple-bit output mode (10 bits or 12 bits) which uses one iTMDS channel is automatically tracked in tandem with the number of output bits regardless of which bit mode was selected.

- * The 8 + 8 bit multi-channel output mode takes effect only when DVI has been selected as the output setting. If iTMDS has been selected, the multiple-bit output mode (10 bits or 12 bits) which uses one iTMDS channel is automatically tracked in tandem with the number of output bits regardless of which bit mode was selected.
- * As shown in the figure below, what is output as the data of channels 1 to 4 for the Master and Slave of Dual Link of VM-1824 is described in this section.
- * Also described below in this section is the Single Link data of the VM-1824-A which is output as the data of channels 1 to 4.

[16-bit (8+8) output Single Link]

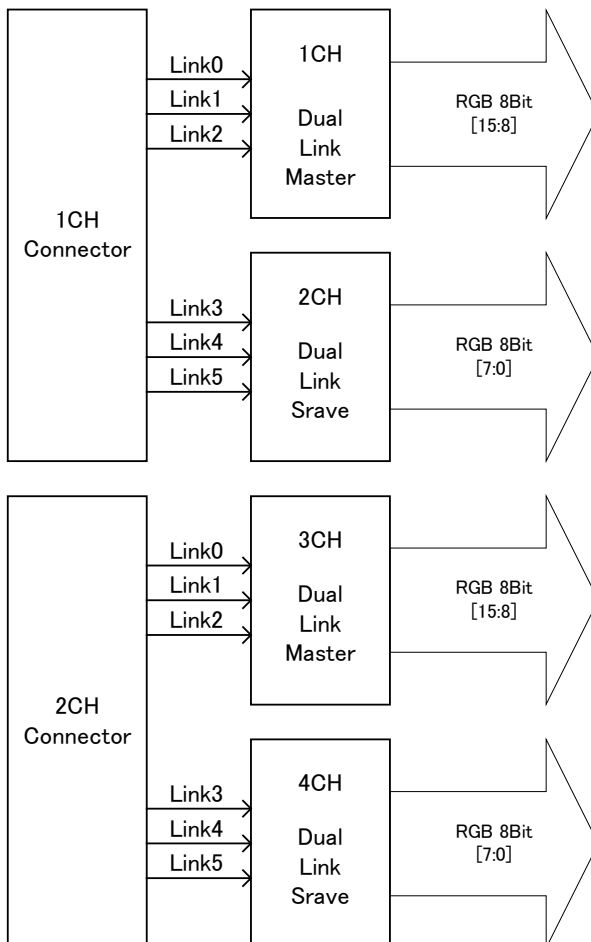

[16-bit (8+8) output Dual Link]

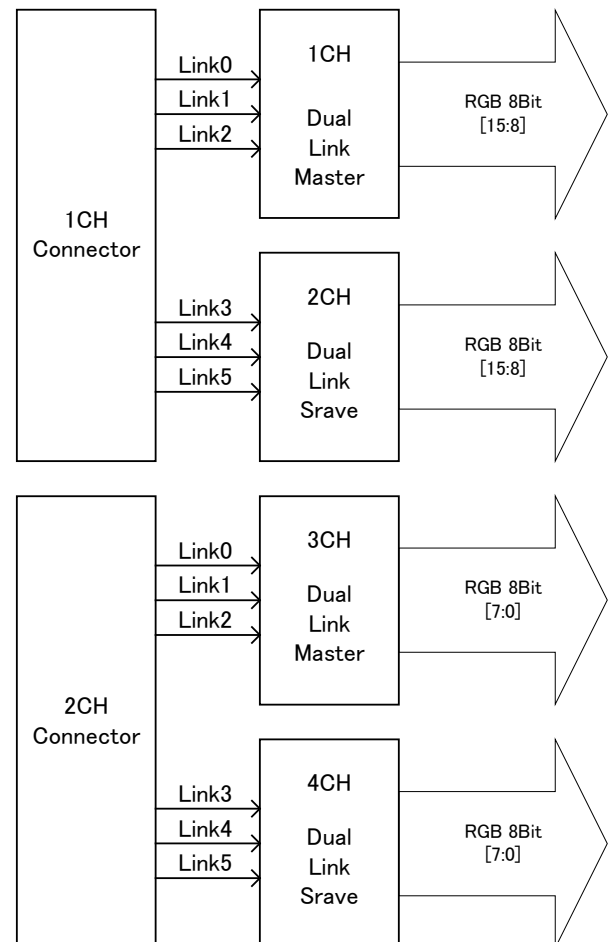

[1] 16Bit (Single Link)

Sixteen-bit images are output using the channel 1 of the Master paired up with the channel 1 of the Slave.

The higher 8 bits are output to channel 1 of the Master and the lower 8 bits to channel 1 of the Slave.

Also, the 16-bit images are output using channel 2 of the Master paired up with channel 2 of the Slave.

The higher 8 bits are output to channel 2 of the Master and the lower 8 bits to channel 2 of the Slave.

Given here as an example for explanatory purposes is a case where the resolution is 1280 × 1024, the dot clock frequency is 108 MHz with the 16 bits output.

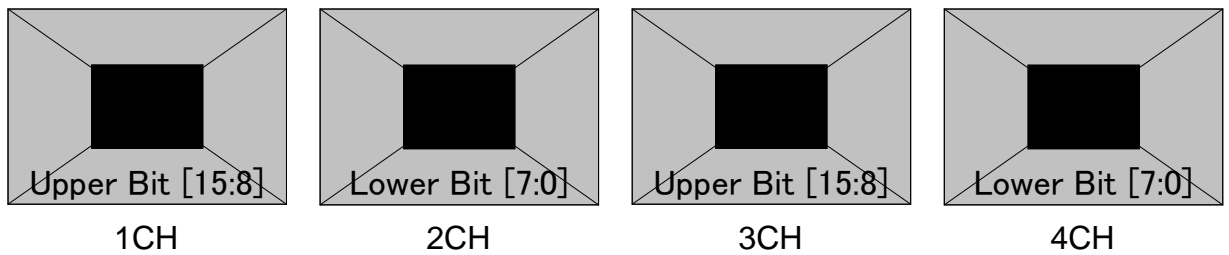
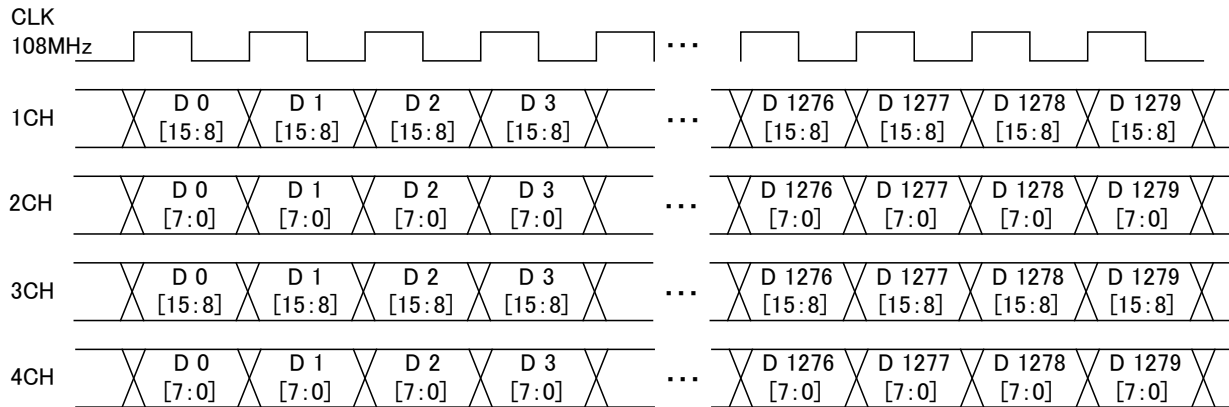

[2] 16Bit (Dual Link)

Dual Link images are output using channel 1 of the Master paired up with channel 1 of the Slave.

The higher 8 bits are output to channel 1.

Also, the Dual Link images are output using the 2-channel of the Master paired up with the 2-channel of the Slave.

The lower 8 bits are output to channel 2.

Given here as an example for explanatory purposes is a case where the resolution is 1280×1024 , the dot clock frequency is 108 MHz with the 16 bits output.

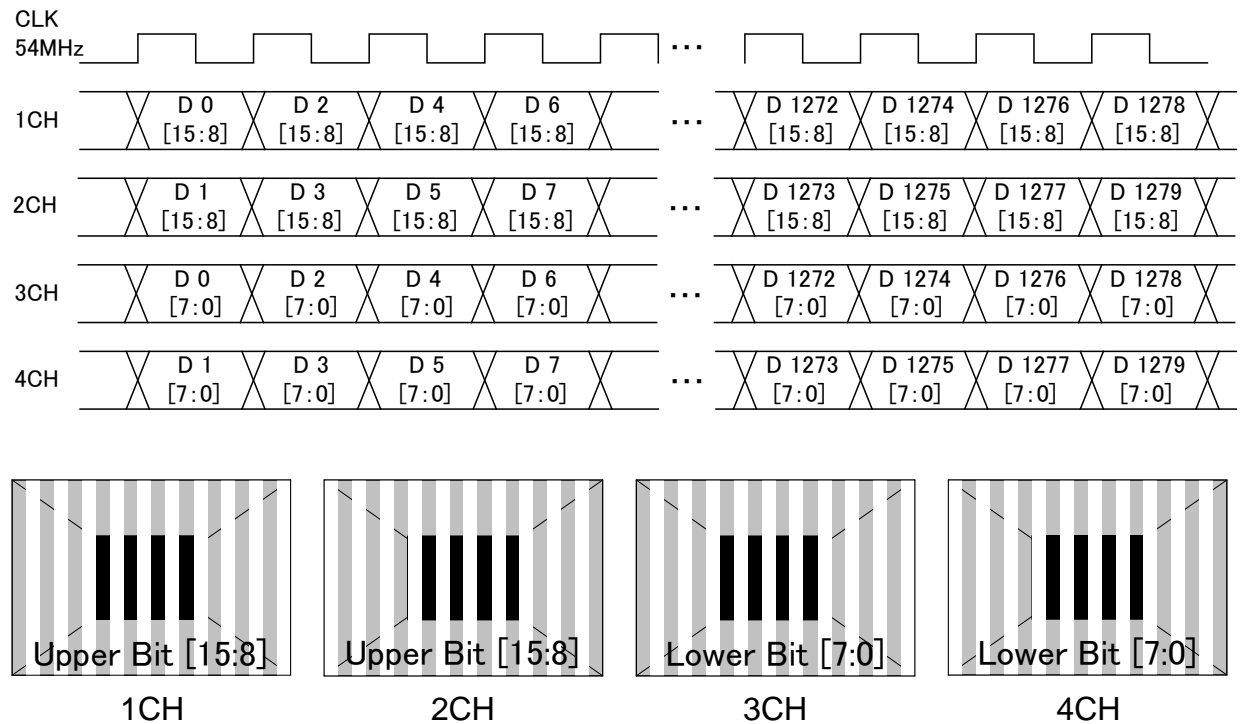

4.4.4 Sync signal polarity settings

For the detailed setting procedure, refer to “4.1.2 Setting the sync signals to ON or OFF and setting the sync signal polarities.”

4.5 LVDS

4.5.1 Connectors and pin assignments

- Connector: MDR 10226-1210-VE made by 3M

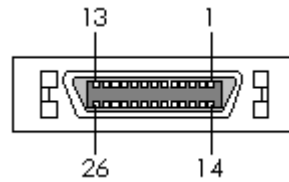







































Pin no.	Signal	Pin no.	Signal
1	GND	14	TA-
2	TAG	15	TA+
3	Reserve (leave this unconnected)	16	GND
4	TB-	17	TBG
5	TB+	18	Reserve (leave this unconnected)
6	TC-	19	TCG
7	TC+	20	TE-
8	TEG	21	TE+
9	Reserve (leave this unconnected)	22	TCLK-
10	TCLKG	23	TCLK+
11	+5 V/+3.3 V (DDC power supply *1)	24	+5 V/+3.3 V (DDC power supply *1)
12	TD-	25	TDG
13	TD+	26	GND

*1: Restrictions apply to the supply current of the DDC power supply. Refer to “**12.3 Concerning the maximum current consumption of the DDC (DP_PWR) power supply.**”

4.5.2 LVDS setting procedure

Some LVDS settings are established for each set of program data, and other LVDS settings are based on the device settings.

■ Settings established for each set of program data













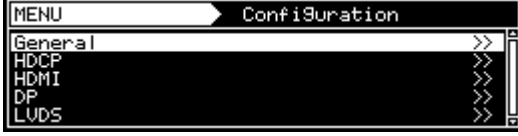



<p>(1) Select Program Edit using    or  INC  DEC  , and then press .</p>	
<p>(2) Select Output (TIM) using  or  INC  DEC  , and then press .</p>	
<p>(3) Select Digital Output using  or  INC  DEC  , and then press .</p>	
<p>(4) Select LVDS using  or  INC  DEC  , and then press .</p>	
<p>(5) Select the items using  or  INC  DEC  , and then press .</p> <p><Inputting the parameters></p> <p>Select the parameters using  or  INC  DEC  , and then press .</p> <p>Alternatively: Select the parameters using the number keys ( to ), and then press .</p>	<p>For further details on the parameters, refer to the table below.</p>

<LVDS setting parameters selected for each set of program data>

(1)	Output 1,2ch (0/1) Output 3,4ch (0/1)	This sets On or Off for each channel. The same settings as the ones described in “4.1.1 Setting the output interfaces to ON or OFF” can also be established.	
		0	Off No output.
		1	On Output.
(2)	Mode (0/1)	This sets the bit length and link format of the images to be output from LVDS. A setting which is independent of the bit length for pattern drawing can be selected. It is also possible to select the bit length automatically. The portion by which the bit length for pattern drawing exceeds the bit length which has been set here is discarded. A deficient portion is filled with zeros. “ Quad ” can be selected when the dot clock frequency ranges from 80 MHz to 340 MHz, and data can be output. “ Dual ” can be selected when the dot clock frequency ranges from 40 MHz to 270 MHz, and data can be output. “ Single ” can be selected when the dot clock frequency ranges from 20 MHz to 135 MHz, and data can be output. “4.1.5 Setting the bit length (gray scale) for pattern drawing”	
		0	Single (10 bits) The data is output by Single Link from output channel 1. The portion by which the bit length for pattern drawing exceeds 10 bits is discarded. The same data as for output channel 1 is output from output channels 2, 3 and 4.
		1	Dual (10 bits) The data is output by Dual Link from output channels 1 and 2. The portion by which the bit length for pattern drawing exceeds 10 bits is discarded. The same data as for output channels 1 and 2 is output from output channels 3 and 4.
		2	Quad (10 bits) The data is output by Quad Link from output channels 1, 2, 3 and 4. The portion by which the bit length for pattern drawing exceeds 10 bits is discarded.
		3	Single (16 bits) The data is output by Single Link from output channels 1 and 2. The portion by which the bit length for pattern drawing is deficient from 16 bits length is filled with zeros. The same data as for output channels 1 and 2 is output from output channels 3 and 4.
		4	Dual (16 bits) The data is output by Quad Link from output channels 1, 2, 3 and 4. The portion by which the bit length for pattern drawing is deficient from 16 bits length is filled with zeros.
		(3) 5	Single (Auto) The data is output by Single Link. Single (10 bits) or Single (16 bits) is automatically selected depending on the bit length for pattern drawing.
		6	Dual (Auto) The data is output by Dual Link. Dual (10 bits) or Dual (16 bits) is automatically selected depending on the bit length for pattern drawing.
(3)	Split	This splits the images to be output, and sets channels 1, 2, 3 and 4 as the output channels. When a setting other than Normal is selected, all other outputs are shut down.	
		The setting below can be selected only when the Single (10 bits) mode has been set.	
		0	Normal
		The setting below can be selected only when the Single (16 bits) mode has been set.	
		0	Normal
		The setting below can be selected only when the Single (Auto) mode has been set.	
		0	Normal

		The setting below can be selected only when the Dual (10 bits) mode has been set.															
	0	Normal															
	1	2Split															
		The setting below can be selected only when the Dual (16 bits) mode has been set.															
	0	Normal															
	1	2Split															
		The setting below can be selected only when the Dual (Auto) mode has been set.															
	0	Normal															
	1	2Split															
		The setting below can be selected only when the Quad (10 bits) mode has been set.															
	0	Normal															
	1	2Split															
	2	4Split															
(4)	Bit Assign (0-4)	<p>This selects the bit assignment. The setting takes effect only when “refer Program” has been selected as the Bit Assign setting among the device settings. For further details, refer to “4.5.4 Bit arrays.”</p> <table border="1"> <tr> <td>0</td> <td>SAMPLE1 (DISM)</td> <td>Based on the DISM standard.</td> </tr> <tr> <td>1</td> <td>SAMPLE2 (OLDI)</td> <td>Based on the OpenLDI standard.</td> </tr> <tr> <td>2</td> <td>User1</td> <td rowspan="4"> These are set by the user. * The actual bit assignment is set using the SP-8870 software program which is provided with the VG generator. </td> </tr> <tr> <td>3</td> <td>User2</td> </tr> <tr> <td>4</td> <td>User3</td> </tr> <tr> <td></td> <td></td> </tr> </table>	0	SAMPLE1 (DISM)	Based on the DISM standard.	1	SAMPLE2 (OLDI)	Based on the OpenLDI standard.	2	User1	These are set by the user. * The actual bit assignment is set using the SP-8870 software program which is provided with the VG generator.	3	User2	4	User3		
0	SAMPLE1 (DISM)	Based on the DISM standard.															
1	SAMPLE2 (OLDI)	Based on the OpenLDI standard.															
2	User1	These are set by the user. * The actual bit assignment is set using the SP-8870 software program which is provided with the VG generator.															
3	User2																
4	User3																
(5)	CTL1 1,2ch (0/1)	This is not normally used. Keep it at the low setting.															
(6)	CTL2 1,2ch (0/1)	This is not normally used. Keep it at the low setting.															
(7)	CTL1 3,4ch (0/1)	This is not normally used. Keep it at the low setting.															
(8)	CTL2 3,4ch (0/1)	This is not normally used. Keep it at the low setting.															

■ Settings common to all programs (device settings)

<p>(1) Select Configuration using  or , and then press .</p>	
<p>(2) Select LVDS using  or , and then press .</p>	
<p>(3) Select the items using  or , and then press .</p> <p><Inputting the parameters></p> <p>Select the parameters using  or , , and then press .</p> <p>Alternatively: Select the parameters using the number keys ( to ) , and then press .</p>	<p>For further details on the parameters, refer to the table below.</p>

<LVDS setting parameters in the device settings>

<p>(1) Bit Assign (0-5)</p>	<p>This selects the bit assignment. For further details, refer to "4.5.4 Bit arrays."</p>	
	<p>0 SAMPLE1 (DISM)</p>	<p>Based on the DISM standard.</p>
	<p>1 SAMPLE2 (OLDI)</p>	<p>Based on the OpenLDI standard.</p>
	<p>2 User1</p>	<p>These are set by the user.</p>
	<p>3 User2</p>	
	<p>4 User3</p>	
<p>5 refer Program</p>	<p>The bit assignment accords with the program settings.</p>	
<p>(2) User Bit Assign</p>	<p>This displays the bit assignment of the user settings. * To edit this parameter, use the SP-8870 software program which is provided with the VG generator.</p>	
<p>(3) Multi Bit Mode (0/1)</p>	<p>This selects the bit assignment to be used when two output connectors are used. For further details, refer to "4.5.4 Bit arrays."</p>	
	<p>0 8+8 bit</p>	
	<p>1 10+6 bit</p>	

4.5.3 Data transfer system

Settings (1) to (6) in the table below are available as the data transfer system settings.

Item	Description	Output from other units
Setting (1)	What is drawn is output as is. (Same output for channels 1 to 4)	ON
Setting (2)	The data is output dot by dot to channels 1 and 2. (Same output for channels 3 and 4)	ON
Setting (3)	The data is output dot by dot to channels 1, 3, 2 and 4.	ON
Setting (4)	The left half of the screen is output to channel 1, and the right half of the screen is output to channel 2. (Same output for channels 3 and 4)	OFF
Setting (5)	One-fourth of the screen each is output to channels 1, 3, 2 and 4 in this order.	OFF
Setting (6)	The left half of the screen is output to channels 1 and 3, and the right half of the screen is output to channels 2 and 4.	OFF

<Specifications for outputs of 8 to 10 bits>

Setting (1) [Single (10 bits)], [Normal]

The same image is output to all four channels. The output level is 8 to 10 bits.

The example is that the resolution is 1280 × 1024, the dot clock frequency is 108 MHz, with the 10 bits output.

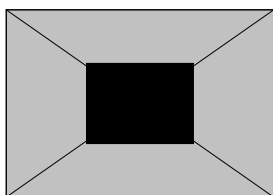
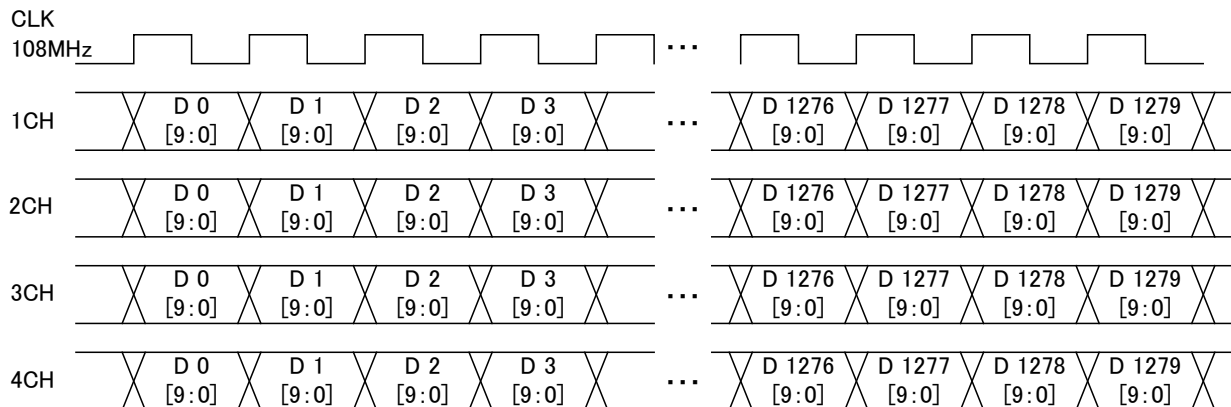

1CH

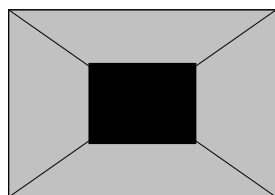

2CH

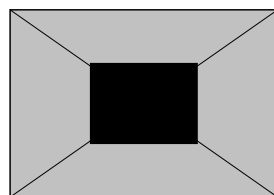

3CH

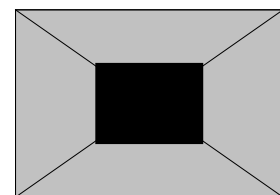

4CH

Setting (2) [Dual (10 bits)], [Normal]

The images are output with channels 1 and 2 forming one set and channels 3 and 4 forming another set.

The output level is 8 to 10 bits.

The example is that the resolution is 1280×1024 , the dot clock frequency is 108 MHz, with the 10 bits output..

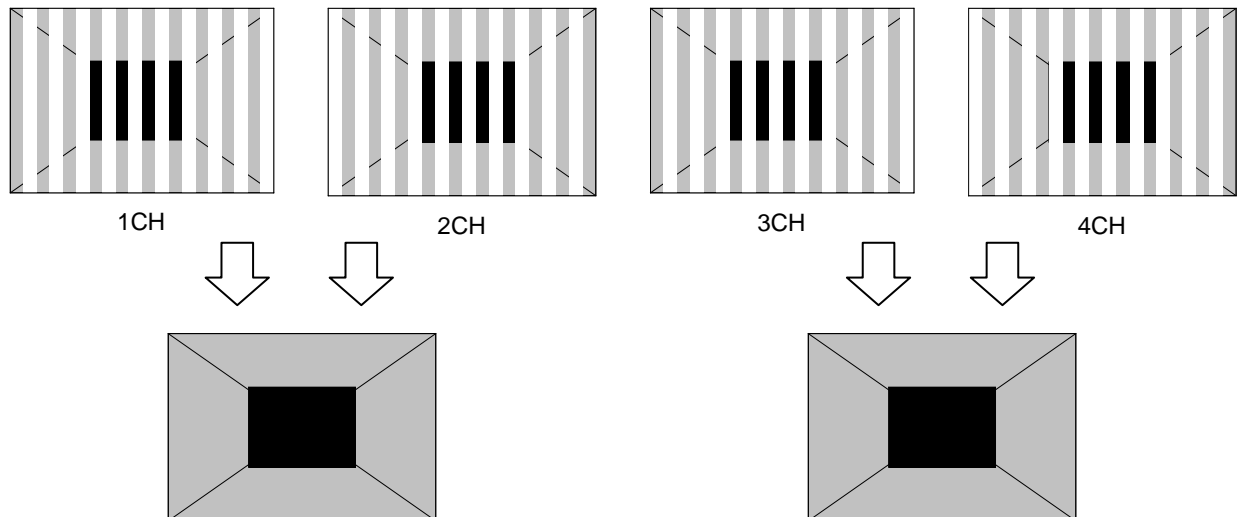
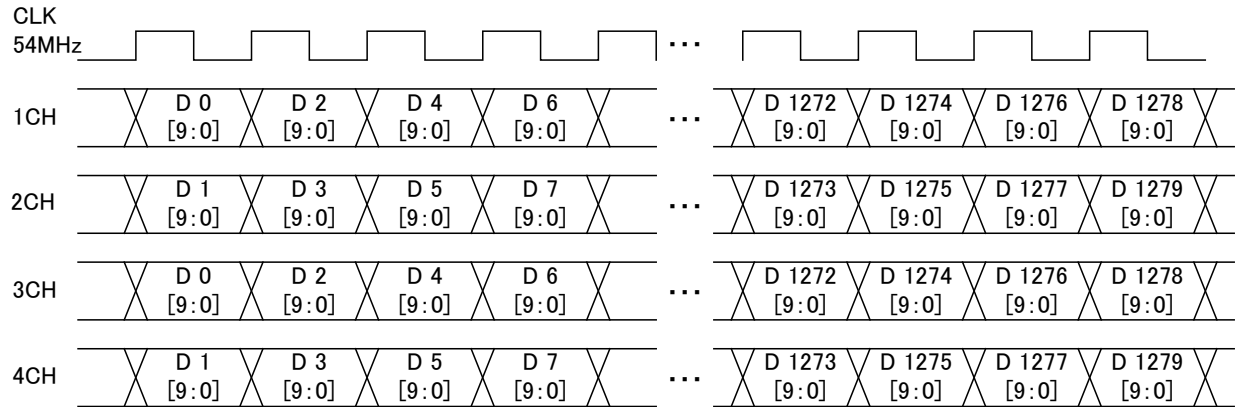

Setting (3) [Quad (10 bits)], [Normal]

The images are output to channels 1, 2, 3 and 4 in this order.

The output level is 8 to 10 bits.

The example is that the resolution is 1280 × 1024, the dot clock frequency is 108 MHz, with the 10 bits output.

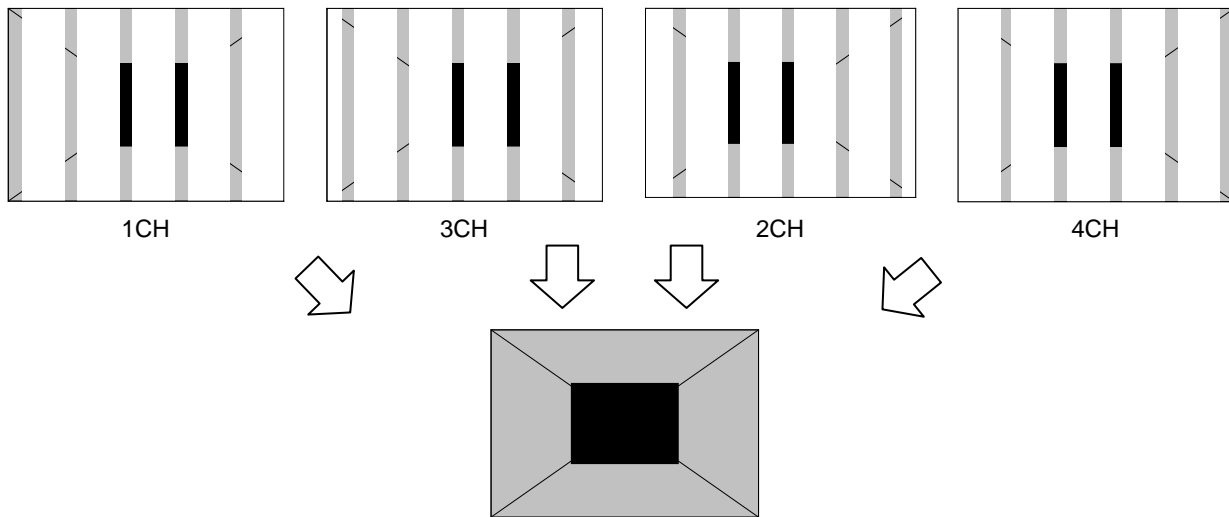
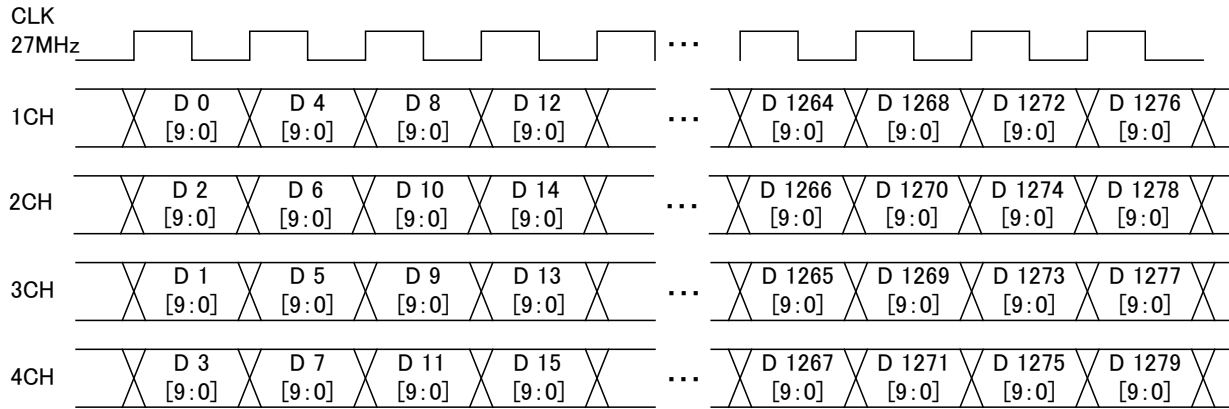

Setting (4) [Dual (10 bits)], [2 split]

The images are output with channels 1 and 2 forming one set and channels 3 and 4 forming another set. If this is described with the channel 1 and 2 set used as an example, the left half of the image is allocated and output to channel 1, and the right half of the image is allocated and output to channel 2.

The output level is 8 to 10 bits.

The example is that the resolution is 1280 × 1024, the dot clock frequency is 108 MHz, with the 10 bits output.

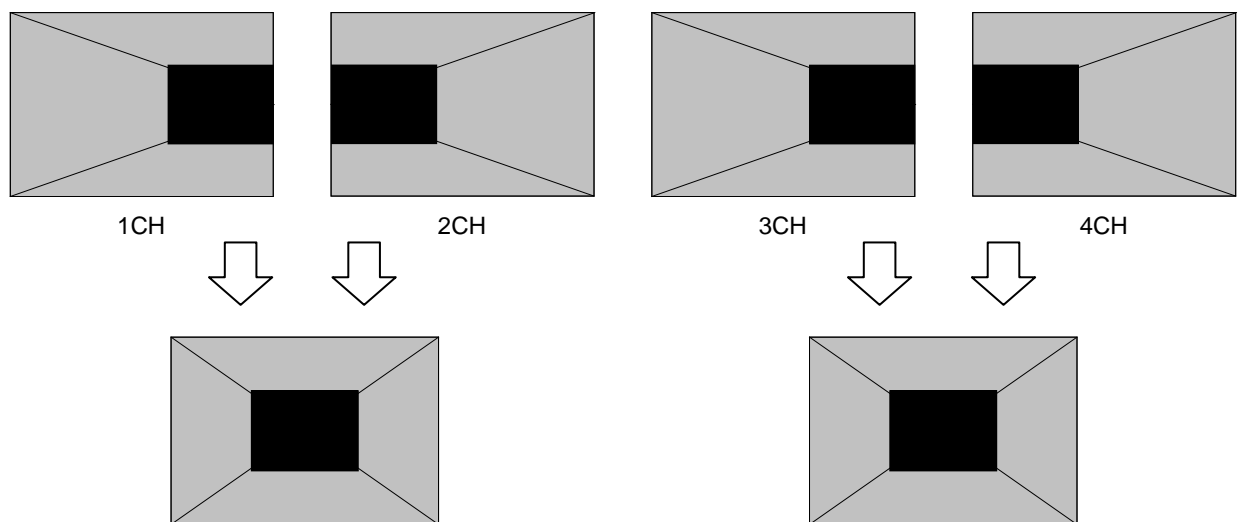
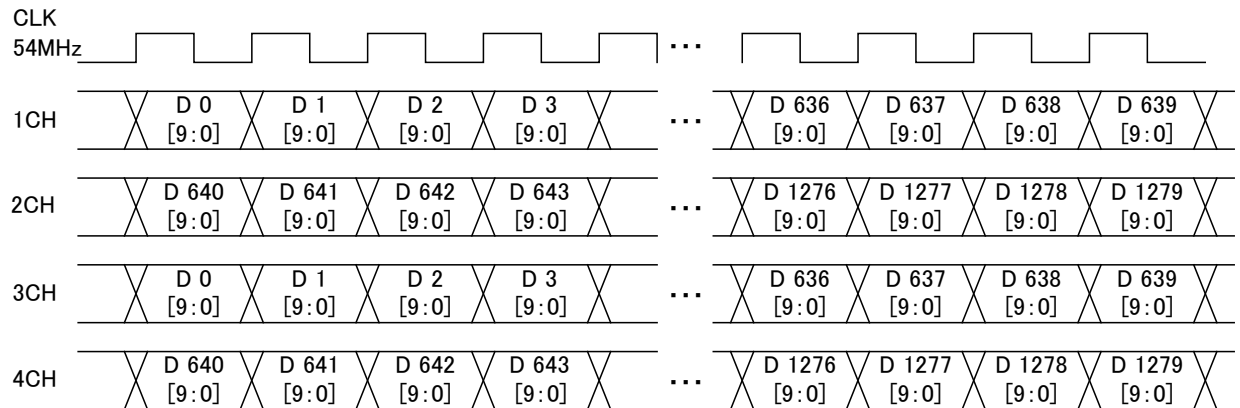

Setting (5) [Quad (10 bits)], [4 split]

The images are split into four parts horizontally, and allocated from the left to channels 1, 3, 2 and 4 in this order.

The output level is 8 to 10 bits.

The example is that the resolution is 1280 × 1024, the dot clock frequency is 108 MHz, with 10 bits output level.

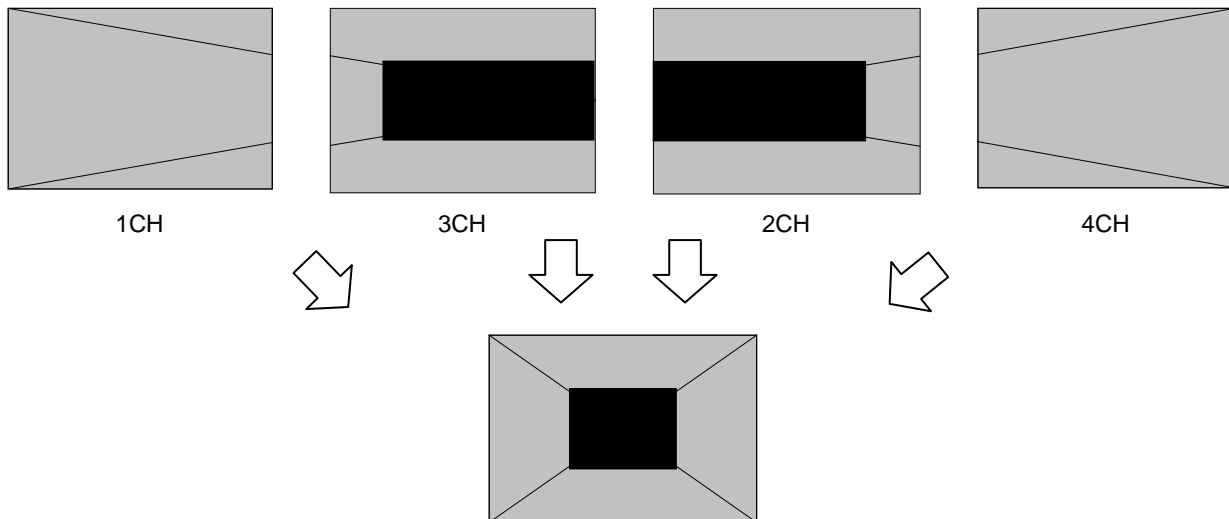
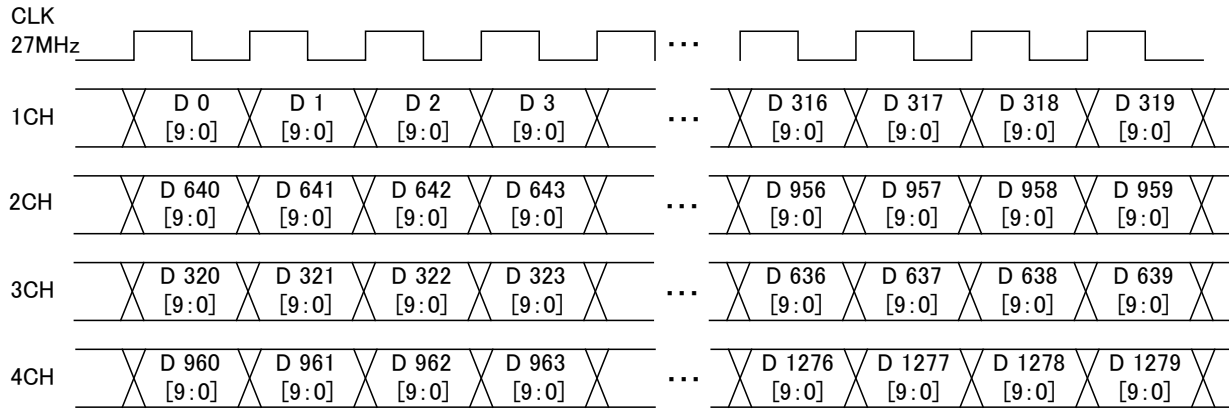

Setting (6) [Quad (10 bits)], [2 split]

The images are output with channels 1 and 3 forming one set and channels 2 and 4 forming another set. The left half of the image is allocated and output to the channel 1 and 3 set, and the right half of the image is allocated to the channel 2 and 4 set.

The output level is 8 to 10 bits.

The example is that the resolution is 1280 × 1024, the dot clock frequency is 108 MHz, with 10 bits output level.

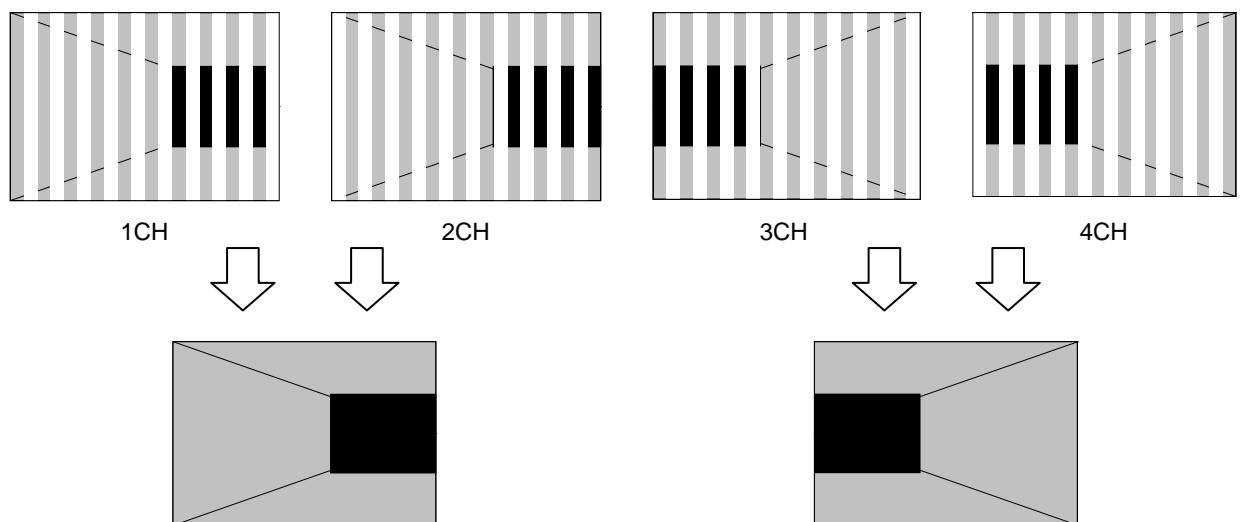
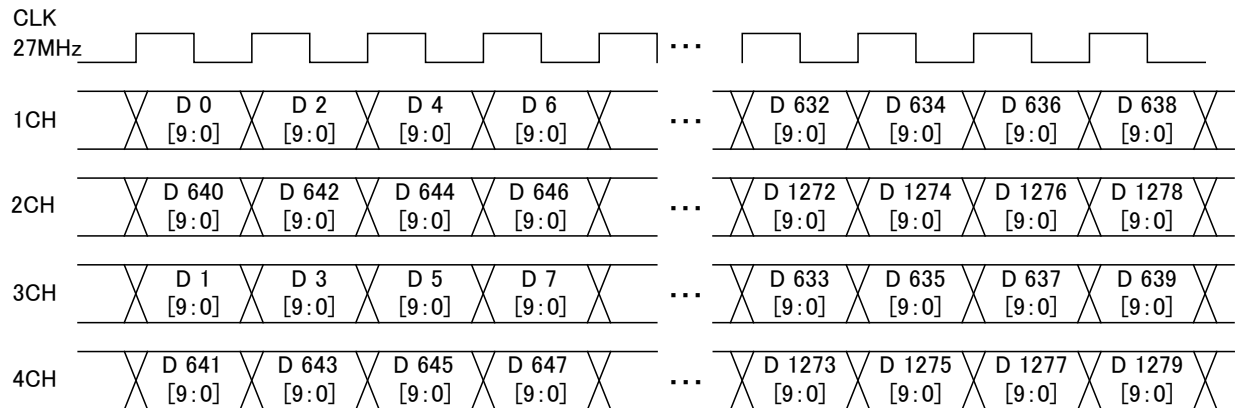

<Specifications for outputs of 11 to 16 bits>

With outputs of 11 to 16 bits, 8 to 10 bits are treated as one output by the channel 1 and 2 set. The bits can be allocated in two ways as shown below. However, when Single (Auto) or Dual (Auto) has been set as the LVDS setting parameter mode, automatic switching is initiated to the channel 1 output for bits 8 to 10 and to the channel 2 output for bits 11 to 16.

When Single (10 bits), Dual (10 bits) or Quad (10 bits) has been set as the setting parameter mode, output is fixed from channel 1.

When Single (16 bits) or Dual (16 bits) has been set as the setting parameter mode, output is fixed from channel 2.

[8 + 8 bits output]

[10 + 6 bits output]

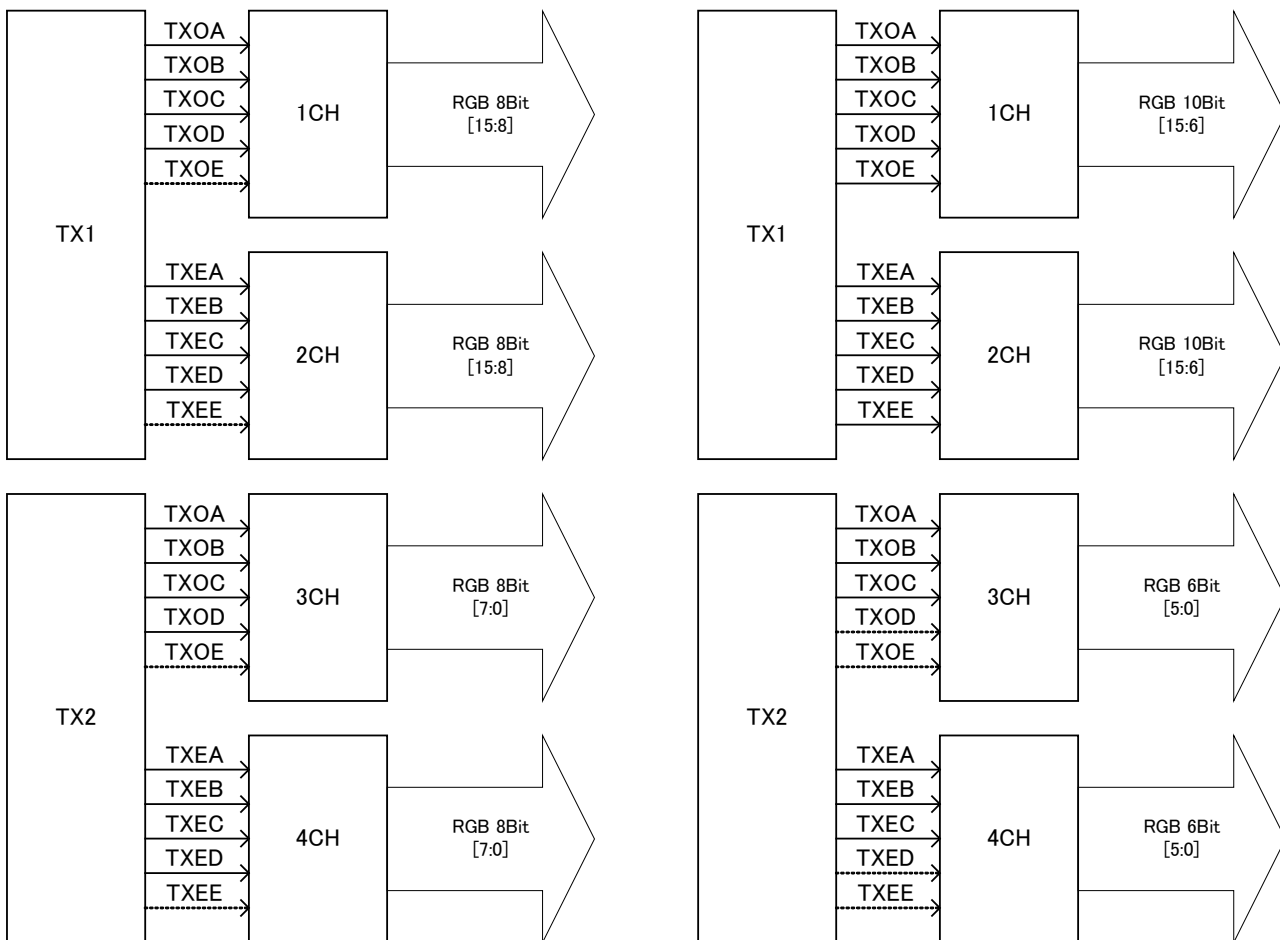

*1: The signal lines indicated by the dotted lines in the above figure are not used.

*2: The specification for 8 + 8 bits output is the default setting.

Setting (1) [Single (16 bits)], [Normal], configuration [10 + 6 bits]

The 16-bit images are output with channels 1 and 3 forming one set and channels 2 and 4 forming another set.

The 10 upper bits are output to channels 1 and 2, and the 6 lower bits are output to channels 3 and 4.

The example given here describes a case where the resolution is 1280×1024 , the dot clock frequency is 108 MHz with 16 bits level, 10 bits are output to channel 1 and 6 bits are output to channel 2.

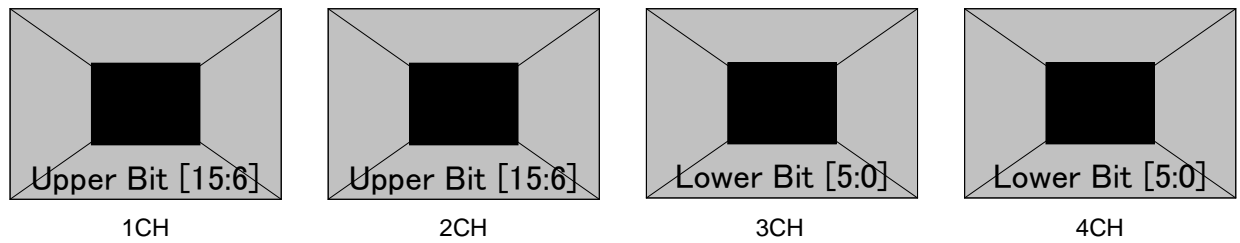
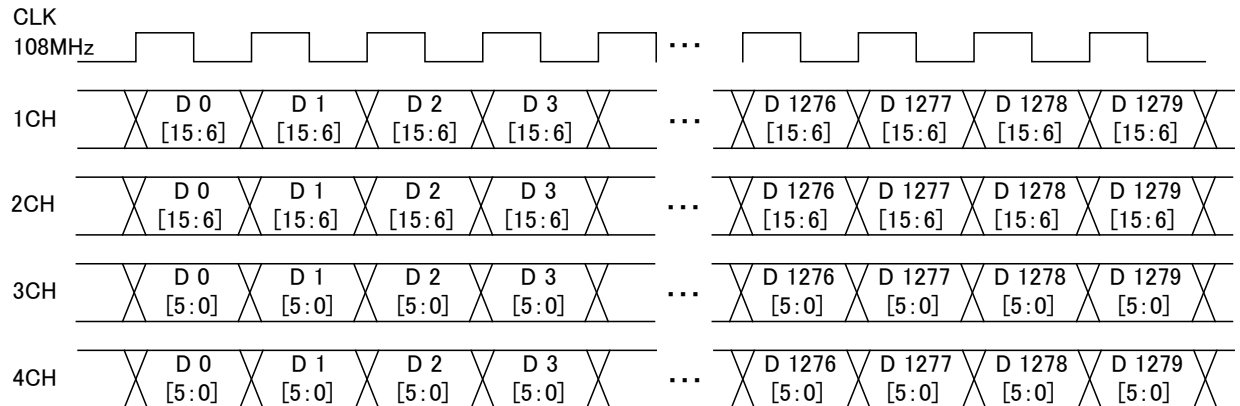

Setting (2) [Dual (16 bits)], [Normal], configuration [10 + 6 bits]

With channels 1 and 3 forming one set and channels 2 and 4 forming another set, odd-numbered fields are output using one set and even-numbered fields are output using the other set.

The 10 upper bits are output to channels 1 and 2, and the remaining 6 lower bits are output to channels 3 and 4.

The example is that the resolution is 1280 × 1024, the dot clock frequency is 108 MHz with 16 bits level, 10 bits are output to channel 1 and 6 bits are output to channel 2.

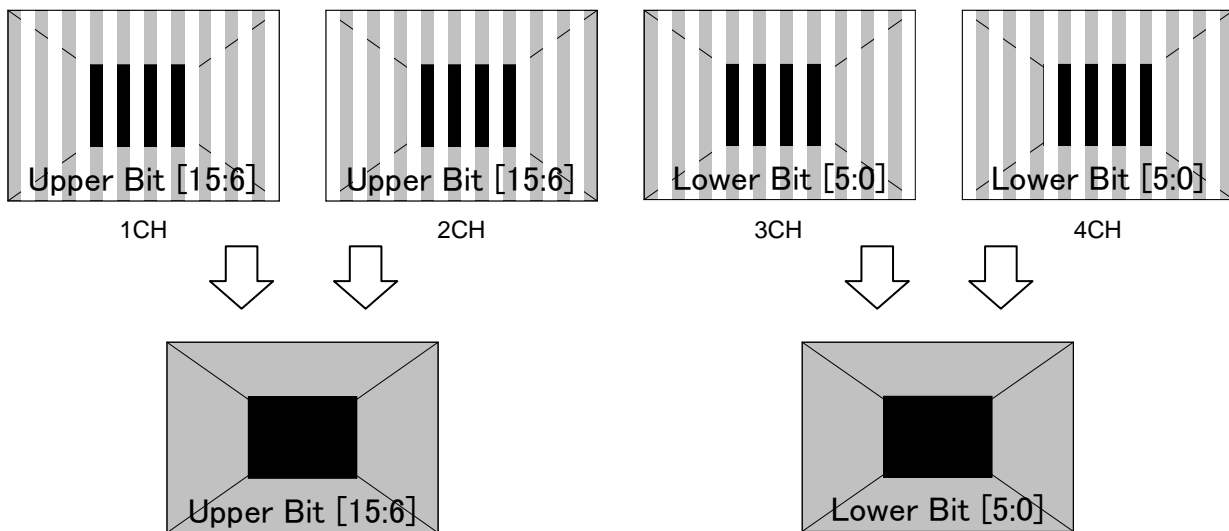
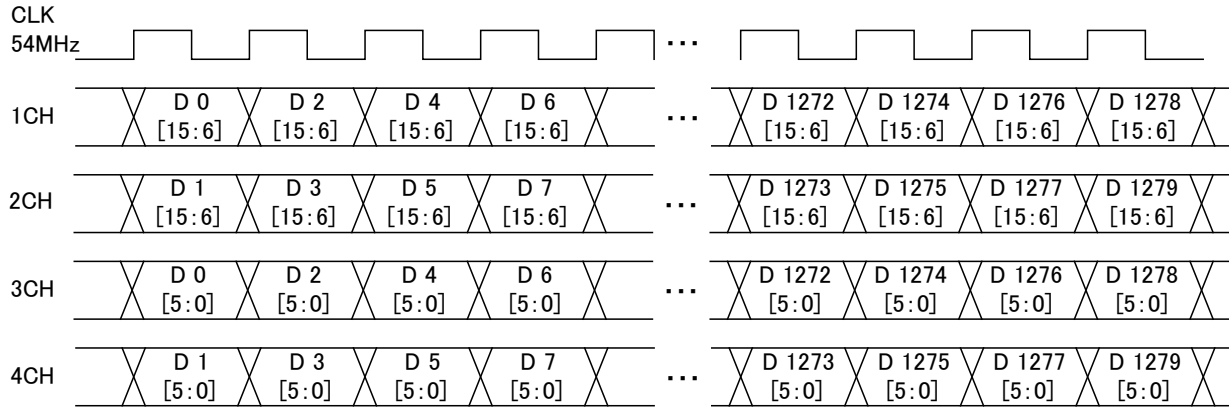

Setting (3) [Dual (16 bits)], [2 split], configuration [10 + 6 bits]

With channels 1 and 3 forming one set and channels 2 and 4 forming another set, the left half of the image is output using one set and the right half of the image is output using the other set.

The 10 upper bits are output to channels 1 and 2, and the remaining 6 lower bits are output to channels 3 and 4.

The example is that the resolution is 1280×1024 , the dot clock frequency is 108 MHz with 16 bits level, 10 bits are output to channel 1 and 6 bits are output to channel 2.

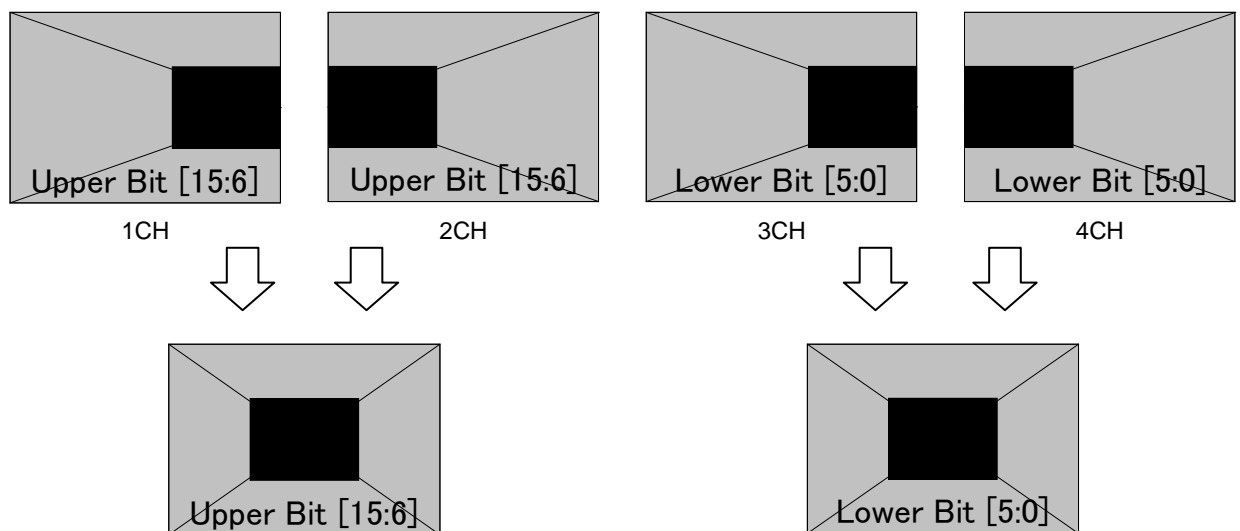
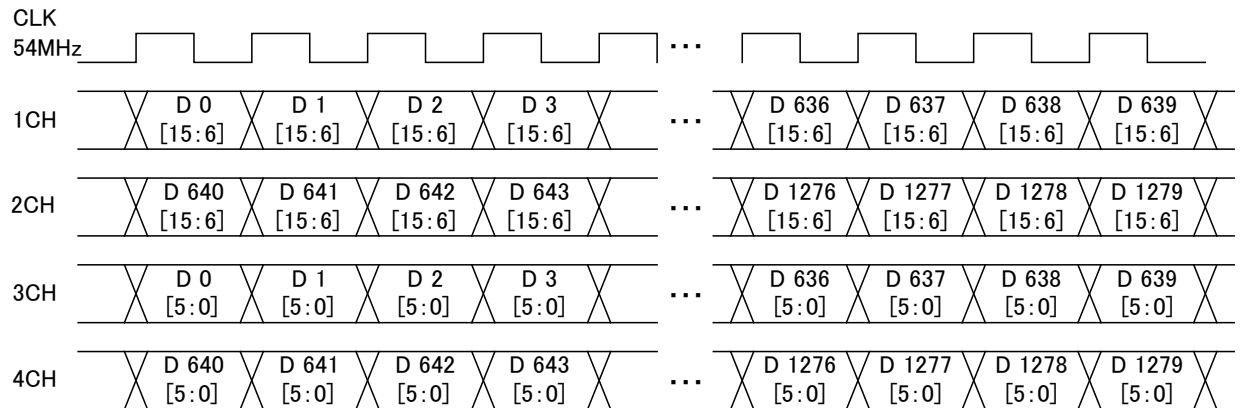

Setting (4) [Single (16 bits)], [Normal], configuration [8 + 8 bits]

The 16-bit images are output with channels 1 and 3 forming one set and channels 2 and 4 forming another set.

The 8 upper bits are output to channels 1 and 2, and the 8 lower bits are output to channels 3 and 4.

The example is that the resolution is 1280 × 1024, the dot clock frequency is 108 MHz with 16 bits level, 8 bits are output to channel 1 and 8 bits are output to channel 2.

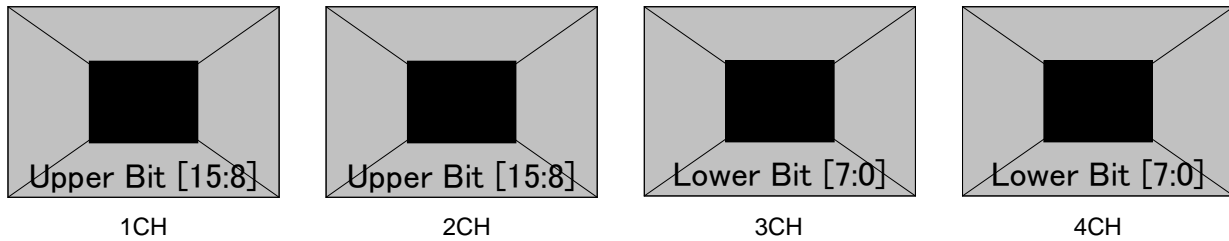
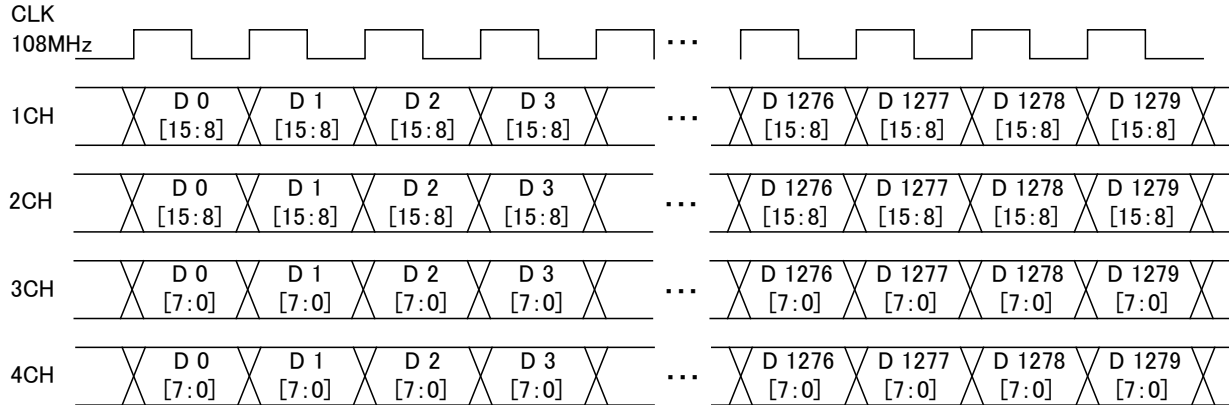

Setting (5) [Dual (16 bits)], [Normal], configuration [8 + 8 bits]

With channels 1 and 3 forming one set and channels 2 and 4 forming another set, odd-numbered fields are output using one set and even-numbered fields are output using the other set.

The 8 upper bits are output to channels 1 and 2, and the 8 lower bits are output to channels 3 and 4.

The example is that the resolution is 1280×1024 , the dot clock frequency is 108 MHz with 16 bits level, 8 bits are output to channel 1 and 8 bits are output to channel 2.

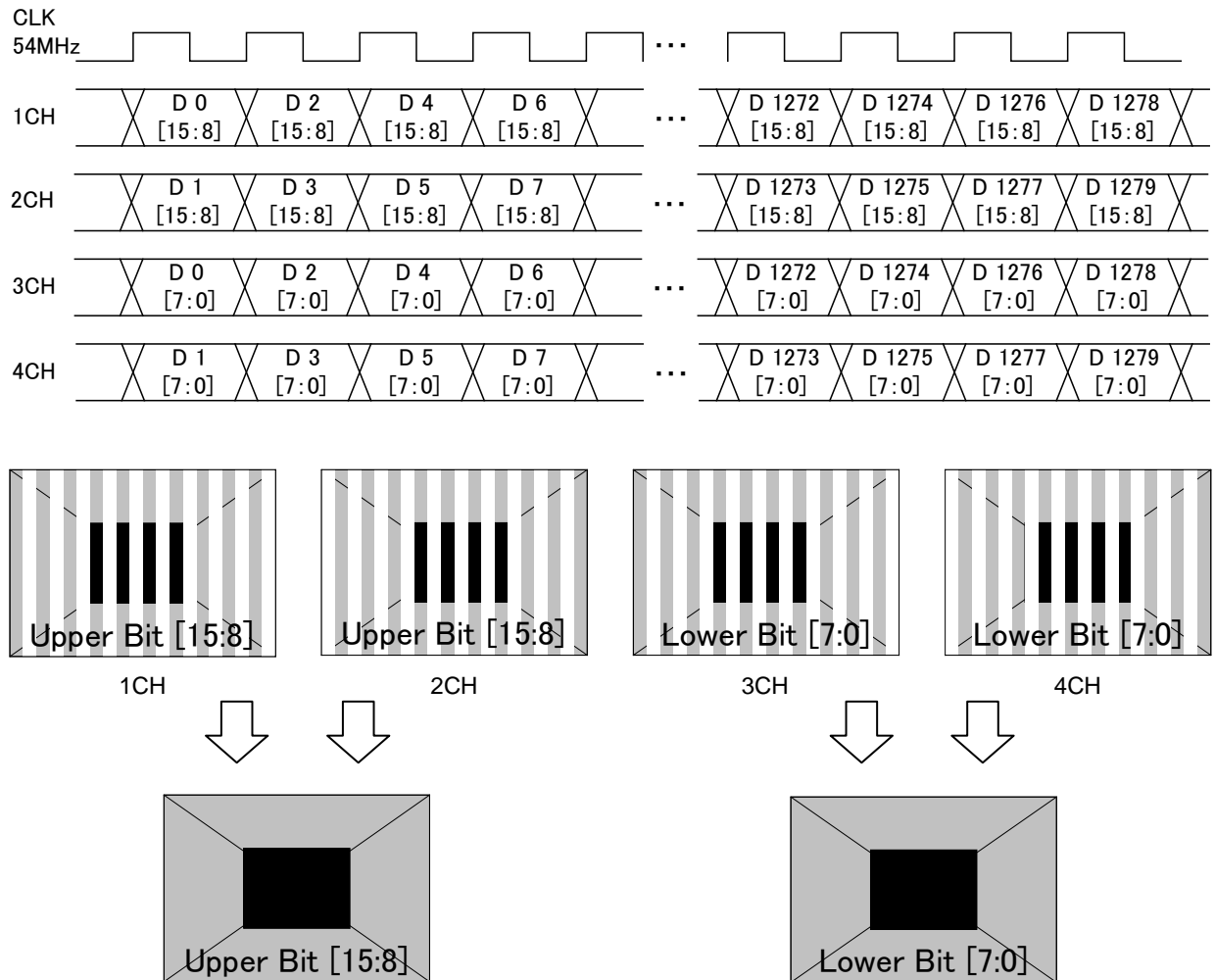

Setting (6) [Dual (16 bits)], [2 split], configuration [8 + 8 bits]

With channels 1 and 3 forming one set and channels 2 and 4 forming another set, the left half of the image is output using one set and the right half of the image is output using the other set.

The 8 upper bits are output to channels 1 and 2, and the remaining 8 lower bits are output to channels 3 and 4.

The example is that the resolution is 1280 × 1024, the dot clock frequency is 108 MHz with 16 bits level, 8 bits are output to channel 1 and 8 bits are output to channel 2.

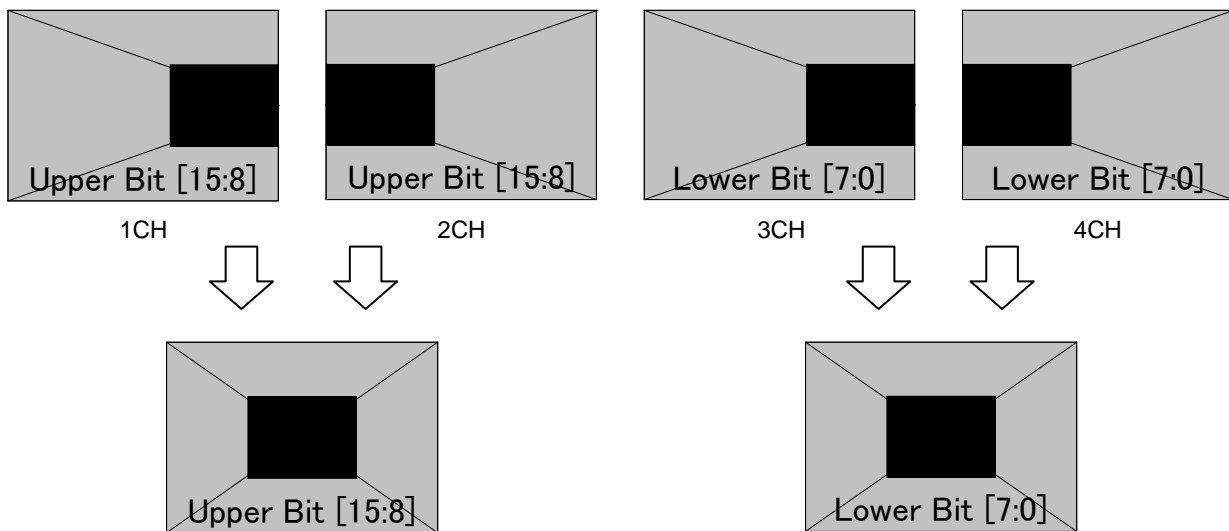
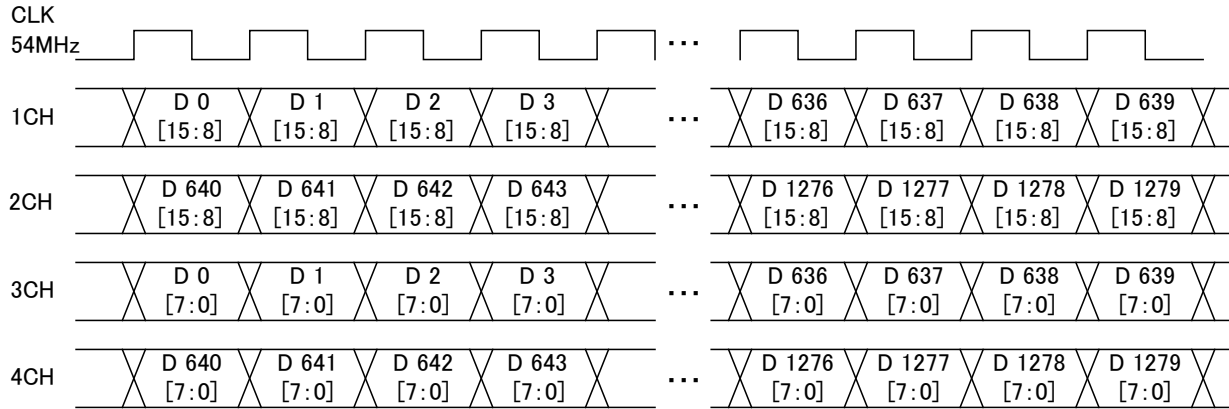

4.5.4 Bit arrays

Bit arrays has the following kinds; SAMPLE1 (DISM standard), SAMPLE2 (OpenLDI standard) and USER (1 to 3) which can be set by users.

For the setting procedure, refer to “4.5.2 LVDS setting procedure.”

● Bit arrays for 8 to 10 bits for using one output connector

Operation signal	Data No.	8-bit mode			10-bit mode		
		SAMPLE1 (DISM)	SAMPLE2 (OpenLDI)	USER	SAMPLE1 (DISM)	SAMPLE2 (OpenLDI)	USER
TA	TA0	R2	R0	R (X)	R4	R0	R (X)
	TA1	R3	R1	R (X)	R5	R1	R (X)
	TA2	R4	R2	R (X)	R6	R2	R (X)
	TA3	R5	R3	R (X)	R7	R3	R (X)
	TA4	R6	R4	R (X)	R8	R4	R (X)
	TA5	R7	R5	R (X)	R9	R5	R (X)
	TA6	G2	G0	G (X)	G4	G0	G (X)
TB	TB0	G3	G1	G (X)	G5	G1	G (X)
	TB1	G4	G2	G (X)	G6	G2	G (X)
	TB2	G5	G3	G (X)	G7	G3	G (X)
	TB3	G6	G4	G (X)	G8	G4	G (X)
	TB4	G7	G5	G (X)	G9	G5	G (X)
	TB5	B2	B0	B (X)	B4	B0	B (X)
	TB6	B3	B1	B (X)	B5	B1	B (X)
TC	TC0	B4	B2	B (X)	B6	B2	B (X)
	TC1	B5	B3	B (X)	B7	B3	B (X)
	TC2	B6	B4	B (X)	B8	B4	B (X)
	TC3	B7	B5	B (X)	B9	B5	B (X)
	TC4	HS	HS	HS	HS	HS	HS
	TC5	VS	VS	VS	VS	VS	VS
	TC6	DE	DE	DE	DE	DE	DE
TD	TD0	R0	R6	R (X)	R2	R6	R (X)
	TD1	R1	R7	R (X)	R3	R7	R (X)
	TD2	G0	G6	G (X)	G2	G6	G (X)
	TD3	G1	G7	G (X)	G3	G7	G (X)
	TD4	B0	B6	B (X)	B2	B6	B (X)
	TD5	B1	B7	B (X)	B3	B7	B (X)
	TD6	L	L	L	L	L	L
TE	TE0	L	L	L	R0	R8	R (X)
	TE1	L	L	L	R1	R9	R (X)
	TE2	L	L	L	G0	G8	G (X)
	TE3	L	L	L	G1	G9	G (X)
	TE4	L	L	L	B0	B8	B (X)
	TE5	L	L	L	B1	B9	B (X)
	TE6	L	L	L	L	L	L

* In the 9-bit mode, the lowest bit of 10-bit mode is discarded and placed to upward.

● Bit arrays for 8 to 16 bits for using two output connectors

Config setting: MultiBitMode/8+8 Bit

Operation signal	Data No.	8- to 16-bit mode					
		SAMPLE1 (DISM)		SAMPLE2 (OpenLDI)		USER	
		CH1,CH2	CH3,CH4	CH1,CH2	CH3,CH4	CH1,CH2	CH3,CH4
TA	TA0	R10	R2	R8	R0	R (X)	R (X)
	TA1	R11	R3	R9	R1	R (X)	R (X)
	TA2	R12	R4	R10	R2	R (X)	R (X)
	TA3	R13	R5	R11	R3	R (X)	R (X)
	TA4	R14	R6	R12	R4	R (X)	R (X)
	TA5	R15	R7	R13	R5	R (X)	R (X)
	TA6	G10	G2	G8	G0	G (X)	G (X)
TB	TB0	G11	G3	G9	G1	G (X)	G (X)
	TB1	G12	G4	G10	G2	G (X)	G (X)
	TB2	G13	G5	G11	G3	G (X)	G (X)
	TB3	G14	G6	G12	G4	G (X)	G (X)
	TB4	G15	G7	G13	G5	G (X)	G (X)
	TB5	B10	B2	B8	B0	B (X)	B (X)
	TB6	B11	B3	B9	B1	B (X)	B (X)
TC	TC0	B12	B4	B10	B2	B (X)	B (X)
	TC1	B13	B5	B11	B3	B (X)	B (X)
	TC2	B14	B6	B12	B4	B (X)	B (X)
	TC3	B15	B7	B13	B5	B (X)	B (X)
	TC4	HS	HS	HS	HS	HS	HS
	TC5	VS	VS	VS	VS	VS	VS
	TC6	DE	DE	DE	DE	DE	DE
TD	TD0	R8	R0	R14	R6	R (X)	R (X)
	TD1	R9	R1	R15	R7	R (X)	R (X)
	TD2	G8	G0	G14	G6	G (X)	G (X)
	TD3	G9	G1	G15	G7	G (X)	G (X)
	TD4	B8	B0	B14	B6	B (X)	B (X)
	TD5	B9	B1	B15	B7	B (X)	B (X)
	TD6	L	L	L	L	L	L
TE	TE0	L	L	L	L	L	L
	TE1	L	L	L	L	L	L
	TE2	L	L	L	L	L	L
	TE3	L	L	L	L	L	L
	TE4	L	L	L	L	L	L
	TE5	L	L	L	L	L	L
	TE6	L	L	L	L	L	L

* If bit width smaller than 16-bit, the lower bits are discarded and the placed upward.

● Bit arrays for 8 to 16 bits for using two output connector

Config setting: MultiBitMode/10+6 Bit

Operation signal	Data No.	8- to 16-bit mode					
		SAMPLE1 (DISM)		SAMPLE1 (OpenLDI)		USER	
		CH1,CH2	CH3,CH4	CH1,CH2	CH3,CH4	CH1,CH2	CH3,CH4
TA	TA0	R10	R0	R6	R0	R (X)	R (X)
	TA1	R11	R1	R7	R1	R (X)	R (X)
	TA2	R12	R2	R8	R2	R (X)	R (X)
	TA3	R13	R3	R9	R3	R (X)	R (X)
	TA4	R14	R4	R10	R4	R (X)	R (X)
	TA5	R15	R5	R11	R5	R (X)	R (X)
	TA6	G10	G0	G6	G0	G (X)	G (X)
TB	TB0	G11	G1	G7	G1	G (X)	G (X)
	TB1	G12	G2	G8	G2	G (X)	G (X)
	TB2	G13	G3	G9	G3	G (X)	G (X)
	TB3	G14	G4	G10	G4	G (X)	G (X)
	TB4	G15	G5	G11	G5	G (X)	G (X)
	TB5	B10	B0	B6	B0	B (X)	B (X)
	TB6	B11	B1	B7	B1	B (X)	B (X)
TC	TC0	B12	B2	B8	B2	B (X)	B (X)
	TC1	B13	B3	B9	B3	B (X)	B (X)
	TC2	B14	B4	B10	B4	B (X)	B (X)
	TC3	B15	B5	B11	B5	B (X)	B (X)
	TC4	HS	HS	HS	HS	HS	HS
	TC5	VS	VS	VS	VS	VS	VS
	TC6	DE	DE	DE	DE	DE	DE
TD	TD0	R8	L	R12	L	R (X)	L
	TD1	R9	L	R13	L	R (X)	L
	TD2	G8	L	G12	L	G (X)	L
	TD3	G9	L	G13	L	G (X)	L
	TD4	B8	L	B12	L	B (X)	L
	TD5	B9	L	B13	L	B (X)	L
	TD6	L	L	L	L	L	L
TE	TE0	R6	L	R14	L	R (X)	L
	TE1	R7	L	R15	L	R (X)	L
	TE2	G6	L	G14	L	G (X)	L
	TE3	G7	L	G15	L	G (X)	L
	TE4	B6	L	B14	L	B (X)	L
	TE5	B7	L	B15	L	B (X)	L
	TE6	L	L	L	L	L	L

* If bit width smaller than 16-bit, the lower bits are discarded and the placed upward.

4.6 Parallel

4.6.1 Connectors and pin assignments



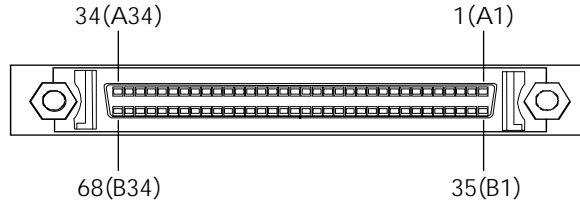



















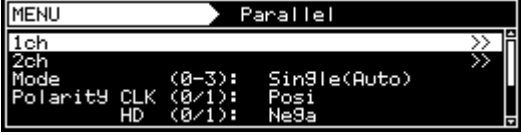

- Connector: 68-pin MINI D (half-pitch pin type)



CH1								CH2							
No.	Signal	No.	Signal	No.	Signal	No.	Signal	No.	Signal	No.	Signal	No.	Signal	No.	Signal
1	(GND)	18	VCC	35	RA0	52	VCC	1	(GND)	18	VCC	35	RB0	52	VCC
2	(GND)	19	GND	36	RA1	53	GND	2	(GND)	19	GND	36	RB1	53	GND
3	(GND)	20	GND	37	RA2	54	GND	3	(GND)	20	GND	37	RB2	54	GND
4	(GND)	21	(GND)	38	RA3	55	HS0	4	(GND)	21	(GND)	38	RB3	55	SW2
5	(GND)	22	(GND)	39	RA4	56	VS0	5	(GND)	22	(GND)	39	RB4	56	SW3
6	(GND)	23	(GND)	40	RA5	57	DISP0	6	(GND)	23	(GND)	40	RB5	57	DISP1
7	(GND)	24	(GND)	41	RA6	58	SW0	7	(GND)	24	(GND)	41	RB6	58	SW1
8	(GND)	25	(GND)	42	RA7	59	BA0	8	(GND)	25	(GND)	42	RB7	59	BB0
9	(GND)	26	(GND)	43	GA0	60	BA1	9	(GND)	26	(GND)	43	GB0	60	BB1
10	(GND)	27	(GND)	44	GA1	61	BA2	10	(GND)	27	(GND)	44	GB1	61	BB2
11	(GND)	28	(GND)	45	GA2	62	BA3	11	(GND)	28	(GND)	45	GB2	62	BB3
12	(GND)	29	(GND)	46	GA3	63	BA4	12	(GND)	29	(GND)	46	GB3	63	BB4
13	(GND)	30	(GND)	47	GA4	64	BA5	13	(GND)	30	(GND)	47	GB4	64	BB5
14	(GND)	31	(GND)	48	GA5	65	BA6	14	(GND)	31	(GND)	48	GB5	65	BB6
15	(GND)	32	(GND)	49	GA6	66	BA7	15	(GND)	32	(GND)	49	GB6	66	BB7
16	(GND)	33	GND	50	GA7	67	GND	16	(GND)	33	GND	50	GB7	67	GND
17	VCC	34	(GND)	51	VCC	68	CLK	17	VCC	34	(GND)	51	VCC	68	CLK

4.6.2 Parallel data setting procedure

Parallel data setting procedure

<p>(1) Select Program Edit using  or , and then press .</p>	
<p>(2) Select Output (TIM) using  or , and then press .</p>	
<p>(3) Select Digital Output using  or , and then press .</p>	
<p>(4) Select Parallel using  or , and then press .</p>	
<p>(5) Select the items using  or , and then press .</p> <p><Inputting the parameters></p> <p>Select the parameters using  or , and then press .</p> <p>Alternatively: Select the parameters using the number keys ( to ), and then press .</p>	<p>For further details on the parameters, refer to the table below.</p>

* The output voltage level can be changed by the switch on the video unit (located on the rear panel of the generator).

For further details on setting procedure, refer to "11.1.7 PARALLEL unit."

Parallel data setting parameters

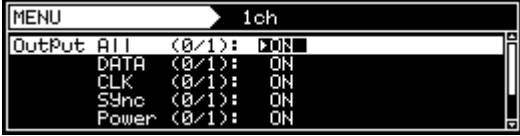
(1)	1ch	 <p>The screenshot shows a menu for channel 1ch with the following settings: Output All (0/1): ON, DATA (0/1): ON, CLK (0/1): ON, Sync (0/1): ON, Power (0/1): ON.</p> <table border="1"> <thead> <tr> <th colspan="3">Output All</th> </tr> </thead> <tbody> <tr> <td>0</td> <td>OFF</td> <td></td> </tr> <tr> <td>1</td> <td>ON</td> <td></td> </tr> <tr> <th colspan="3">DATA</th> </tr> <tr> <td>0</td> <td>Hiz</td> <td>This sets the parallel data to the high-impedance (HiZ) state.</td> </tr> <tr> <td>1</td> <td>ON</td> <td>This outputs the parallel data.</td> </tr> <tr> <th colspan="3">CLK</th> </tr> <tr> <td>0</td> <td>Hiz</td> <td>This sets the CLK signal to the high-impedance (HiZ) state.</td> </tr> <tr> <td>1</td> <td>ON</td> <td>This outputs the parallel clock signal.</td> </tr> <tr> <th colspan="3">Sync</th> </tr> <tr> <td>0</td> <td>Hiz</td> <td>This sets the parallel clock signal to the high-impedance (HiZ) state.</td> </tr> <tr> <td>1</td> <td>ON</td> <td>This outputs the parallel clock signal.</td> </tr> <tr> <th colspan="3">Power</th> </tr> <tr> <td>0</td> <td>Hiz</td> <td>This sets the parallel power supply to the high-impedance (HiZ) state.</td> </tr> <tr> <td>1</td> <td>ON</td> <td>This outputs the parallel power. For further details on the settings, refer to "1.5.6 Parallel unit"</td> </tr> <tr> <th colspan="3">SW</th> </tr> <tr> <td>0</td> <td>CS</td> <td>CS output from SW</td> </tr> <tr> <td>1</td> <td>VD</td> <td>VD output from SW</td> </tr> <tr> <td>2</td> <td>HD</td> <td>HD output from SW</td> </tr> <tr> <td>3</td> <td>Low</td> <td>Fix SW to Low</td> </tr> <tr> <td>4</td> <td>High</td> <td>Fix SW to High</td> </tr> </tbody> </table>	Output All			0	OFF		1	ON		DATA			0	Hiz	This sets the parallel data to the high-impedance (HiZ) state.	1	ON	This outputs the parallel data.	CLK			0	Hiz	This sets the CLK signal to the high-impedance (HiZ) state.	1	ON	This outputs the parallel clock signal.	Sync			0	Hiz	This sets the parallel clock signal to the high-impedance (HiZ) state.	1	ON	This outputs the parallel clock signal.	Power			0	Hiz	This sets the parallel power supply to the high-impedance (HiZ) state.	1	ON	This outputs the parallel power. For further details on the settings, refer to "1.5.6 Parallel unit"	SW			0	CS	CS output from SW	1	VD	VD output from SW	2	HD	HD output from SW	3	Low	Fix SW to Low	4	High	Fix SW to High
Output All																																																																	
0	OFF																																																																
1	ON																																																																
DATA																																																																	
0	Hiz	This sets the parallel data to the high-impedance (HiZ) state.																																																															
1	ON	This outputs the parallel data.																																																															
CLK																																																																	
0	Hiz	This sets the CLK signal to the high-impedance (HiZ) state.																																																															
1	ON	This outputs the parallel clock signal.																																																															
Sync																																																																	
0	Hiz	This sets the parallel clock signal to the high-impedance (HiZ) state.																																																															
1	ON	This outputs the parallel clock signal.																																																															
Power																																																																	
0	Hiz	This sets the parallel power supply to the high-impedance (HiZ) state.																																																															
1	ON	This outputs the parallel power. For further details on the settings, refer to "1.5.6 Parallel unit"																																																															
SW																																																																	
0	CS	CS output from SW																																																															
1	VD	VD output from SW																																																															
2	HD	HD output from SW																																																															
3	Low	Fix SW to Low																																																															
4	High	Fix SW to High																																																															
(2)	2ch	<p>The settings from Output to Power are the same as for channel 1.</p> <table border="1"> <thead> <tr> <th colspan="3">SW1</th> </tr> </thead> <tbody> <tr> <td>0</td> <td>CS</td> <td>CS output from SW1</td> </tr> <tr> <td>1</td> <td>VD</td> <td>VD output from SW1</td> </tr> <tr> <td>2</td> <td>HD</td> <td>HD output from SW1</td> </tr> <tr> <td>3</td> <td>Low</td> <td>Fix SW1 to Low</td> </tr> <tr> <td>4</td> <td>High</td> <td>Fix SW1 to High</td> </tr> <tr> <th colspan="3">SW2</th> </tr> <tr> <td>0</td> <td>HS</td> <td>HS output from SW2</td> </tr> <tr> <td>1</td> <td>VD</td> <td>VD output from SW2</td> </tr> <tr> <td>2</td> <td>HD</td> <td>HD output from SW2</td> </tr> <tr> <td>3</td> <td>Low</td> <td>Fix SW2 to Low</td> </tr> <tr> <td>4</td> <td>High</td> <td>Fix SW2 to High</td> </tr> <tr> <th colspan="3">SW3</th> </tr> <tr> <td>0</td> <td>VS</td> <td>VS output from SW3</td> </tr> <tr> <td>1</td> <td>VD</td> <td>VD output from SW3</td> </tr> <tr> <td>2</td> <td>HD</td> <td>HD output from SW3</td> </tr> <tr> <td>3</td> <td>Low</td> <td>Fix SW3 to Low</td> </tr> <tr> <td>4</td> <td>High</td> <td>Fix SW3 to High</td> </tr> </tbody> </table>	SW1			0	CS	CS output from SW1	1	VD	VD output from SW1	2	HD	HD output from SW1	3	Low	Fix SW1 to Low	4	High	Fix SW1 to High	SW2			0	HS	HS output from SW2	1	VD	VD output from SW2	2	HD	HD output from SW2	3	Low	Fix SW2 to Low	4	High	Fix SW2 to High	SW3			0	VS	VS output from SW3	1	VD	VD output from SW3	2	HD	HD output from SW3	3	Low	Fix SW3 to Low	4	High	Fix SW3 to High									
SW1																																																																	
0	CS	CS output from SW1																																																															
1	VD	VD output from SW1																																																															
2	HD	HD output from SW1																																																															
3	Low	Fix SW1 to Low																																																															
4	High	Fix SW1 to High																																																															
SW2																																																																	
0	HS	HS output from SW2																																																															
1	VD	VD output from SW2																																																															
2	HD	HD output from SW2																																																															
3	Low	Fix SW2 to Low																																																															
4	High	Fix SW2 to High																																																															
SW3																																																																	
0	VS	VS output from SW3																																																															
1	VD	VD output from SW3																																																															
2	HD	HD output from SW3																																																															
3	Low	Fix SW3 to Low																																																															
4	High	Fix SW3 to High																																																															

(3)	Mode (0/1)	This sets the bit length and link format of the images to be output from the parallel connector. A setting which is independent of the bit length for pattern drawing can be selected. It is also possible to select the bit length automatically. The portion by which the bit length for pattern drawing exceeds the bit length which has been set here is discarded. A deficient portion is filled with zeros. “Single” can be selected when the dot clock frequency ranges from 0.1 MHz to 100 MHz, and the data can be output. “Dual” can be selected when the dot clock frequency ranges from 0.2 MHz to 200 MHz, and the data can be output. “4.1.5 Setting the bit length (gray scale) for pattern drawing”		
		0	Single (8 bits)	The data is output by Single Link from output channel 1. The portion by which the bit length for pattern drawing exceeds 8 bits is discarded. The same data as for output channel 1 is output for channel 2.
		1	Dual (8 bits)	The data is output by Dual Link from output channels 1 and 2. The portion by which the bit length for pattern drawing exceeds 8 bits is discarded.
		2	Single (16 bits)	The data is output by Single Link from output channels 1 and 2. The portion by which the bit length for pattern drawing is deficient from 16 bits is discarded.
		3	Single (Auto)	The data is output by Single Link. Single (10 bits) or Single (16 bits) is automatically selected depending on the bit length for pattern drawing.
(4)	Polarity CLK (0/1)	This selects whether to reverse the polarity of the parallel clock signal.		
		0	Nega	This outputs the clock signal with a reversed polarity.
		1	Posi	This outputs the clock signal with a non-reversed polarity.
(5)	HD (0/1)	This selects whether to reverse the polarity of the parallel HD. For further details of the setting procedure, refer to “3.2 Vertical timing data editing.”		
		0	Nega	This outputs the clock signal with a reversed polarity.
		1	Posi	This outputs the clock signal with a non-reversed polarity.
(6)	VD (0/1)	This selects whether to reverse the polarity of the parallel VD. For further details of the setting procedure, refer to “3.2 Vertical timing data editing.”		
		0	Nega	This outputs the clock signal with a reversed polarity.
		1	Posi	This outputs the clock signal with a non-reversed polarity.
(7)	CS (0/1)	This selects whether to reverse the polarity of the parallel CS.		
		0	Nega	This outputs the clock signal with a reversed polarity.
		1	Posi	This outputs the clock signal with a non-reversed polarity.
(8)	DISP (0/1)	This selects whether to reverse the polarity of the parallel DISP.		
		0	Nega	This outputs the clock signal with a reversed polarity.
		1	Posi	This outputs the clock signal with a non-reversed polarity.

4.7 Analog component signals

4.7.1 Connectors and output signals

■ TV encoder board component outputs (BNC)

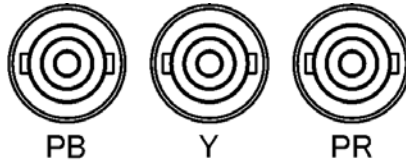

Connector	Signal
PB	Pb
Y	Y
PR	Pr

■ PC unit board component outputs (BNC)

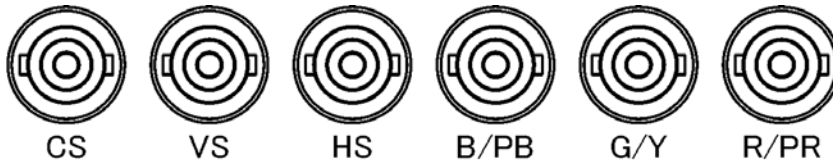



















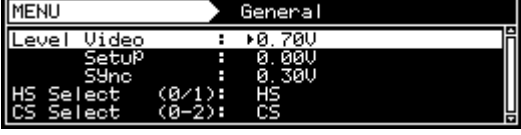



Connector	Signal
CS	CS
VS	VS
HS	HS
B/PB	B or Pb
G/Y	G or Y
R/PR	R or Pr

4.7.2 Setting the analog output connectors

The analog component signals and output signals from the HS and CS connectors can be set for each program.

<p>(1) Select Program Edit using or , and then press .</p>	
<p>(2) Select Output (TIM) using or , and then press .</p>	

<p>(3) Select Analog Output using  or   , and then press   .</p>																													
<p>(4) Select General using  or   , and then press  .</p>																													
<p>(5) Select the items using  or   , and then press  .</p> <p>Set the numerical values using  or   , and then press  .</p> <p>Alternatively: Make the selections using the number keys ( to ), and then press  .</p>	<p>The parameters are set here.</p> <table border="1"> <tr> <td rowspan="2">Video</td> <td colspan="2">The video level is set here.</td> </tr> <tr> <td>0.05-1.20 V</td> <td>Video-On-Sync is in the off state.</td> </tr> <tr> <td></td> <td>0.30-1.20 V</td> <td>Video-On-Sync is in the on state.</td> </tr> <tr> <td>Setup</td> <td>0.00-0.25 V</td> <td>The setup level is set here.</td> </tr> <tr> <td>Sync</td> <td>0.00 to 0.60 V</td> <td>The sync signal (Video-On-Sync) level is set here.</td> </tr> <tr> <td rowspan="2">HS Select</td> <td>0</td> <td>HS</td> <td rowspan="2">The signal to be output from the HS connector is selected here.</td> </tr> <tr> <td>1</td> <td>CS</td> </tr> <tr> <td rowspan="3">CS Select</td> <td>0</td> <td>CS</td> <td rowspan="3">The signal to be output from the CS connector is selected here.</td> </tr> <tr> <td>1</td> <td>HS</td> </tr> <tr> <td>2</td> <td>VS</td> </tr> </table>	Video	The video level is set here.		0.05-1.20 V	Video-On-Sync is in the off state.		0.30-1.20 V	Video-On-Sync is in the on state.	Setup	0.00-0.25 V	The setup level is set here.	Sync	0.00 to 0.60 V	The sync signal (Video-On-Sync) level is set here.	HS Select	0	HS	The signal to be output from the HS connector is selected here.	1	CS	CS Select	0	CS	The signal to be output from the CS connector is selected here.	1	HS	2	VS
Video	The video level is set here.																												
	0.05-1.20 V	Video-On-Sync is in the off state.																											
	0.30-1.20 V	Video-On-Sync is in the on state.																											
Setup	0.00-0.25 V	The setup level is set here.																											
Sync	0.00 to 0.60 V	The sync signal (Video-On-Sync) level is set here.																											
HS Select	0	HS	The signal to be output from the HS connector is selected here.																										
	1	CS																											
CS Select	0	CS	The signal to be output from the CS connector is selected here.																										
	1	HS																											
	2	VS																											
<p></p>	<p>Display returns to the initial screen.</p>																												



Set within the range of [Video ≥ Setup] and [Video ≥ Sync] and [Video ≥ (Setup + Sync)].

4.7.3 Setting the analog video level

For details on changing the analog video level, refer to “4.1.7 Setting the analog level.”

4.7.4 Sync signal settings

For further details on the sync signal ON/OFF settings and polarity settings, refer to “4.1.2 Setting the sync signals to ON or OFF and setting the sync signal polarities.”

4.8 Composite connector and Y/C connector (S connector)

4.8.1 Connectors and output signals

■ Composite connector



Connector	Signal
COMPOSITE	Composite video

■ Y/C connector (S connector)

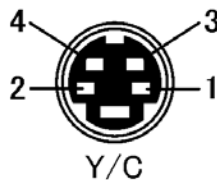

Pin no.	Signal
1	GND
2	GND
3	Y
4	C

■ Concerning the output signals

The following video signals can be output from the composite connector and Y/C connector of the TV encoder unit.

- NTSC-M, NTSC-J, NTSC-443
- PAL-60, PAL, PAL-M, PAL-N, PAL-Nc
- SECAM

CAUTION

- If the timing of the composite and Y/C signals (such as the period and sync width data) has been changed from that in the internal program, it may no longer be possible to draw the patterns on the monitor correctly.

■ Difference between VM-1812 and VM-1812-B (VM-1812-B is not released yet.)

VM-1812-B has the following restriction.

- PAL-N, PAL-60 and SECAM are not supported.
- Option Pattern No. 77 (SMPTE Color SVBS) is not supported.







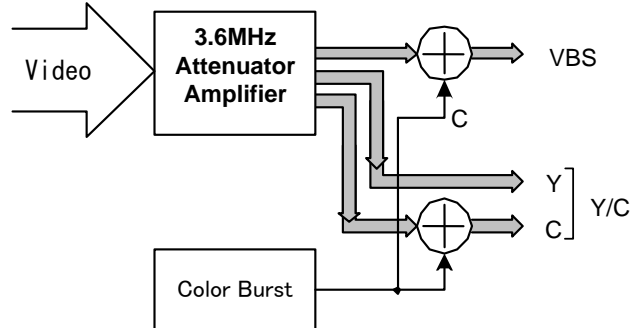







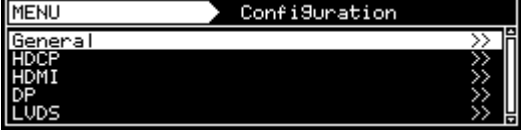



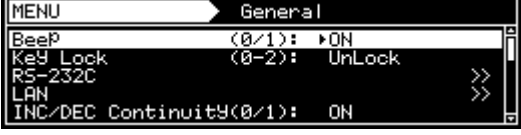

4.8.2 Composite signal filter settings

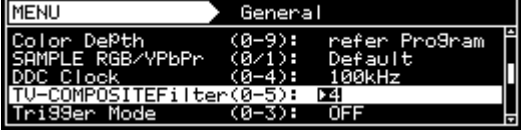
The amount of attenuation (or gain) in the 3.6 MHz frequency of the composite and Y/C signals can be set.

This setting is processed before the chrominance is added to the video signals so that the color burst is not affected.



Setting procedure











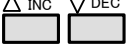





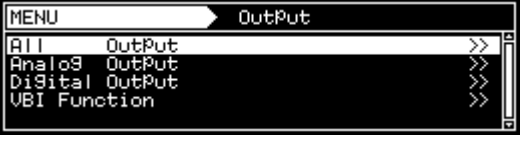







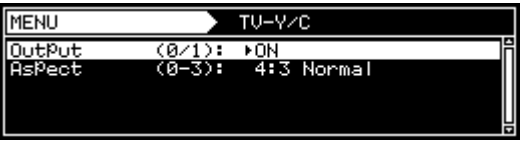

<p>(1) Select Configuration using  or  , and then press .</p>																			
<p>(2) Select General using  or  , and then press .</p>																			
<p>(3) Select TV-COMPOSITE Filter using  or  , and then press .</p>																			
<p>(4) <Inputting the parameters> Select the parameters using  or  , and then press .</p> <p>Alternatively: Select the parameters using the number keys <small>0/STATUS</small>  to <small>9/F</small> , and then press .</p>	<p>The edges are enhanced or smoothed by the TV-COMPOSITE Filter setting.</p> <table border="1"> <tbody> <tr> <td>0</td> <td>3.5 dB gain</td> <td>The edges are enhanced.</td> </tr> <tr> <td>1</td> <td>1.0 dB gain</td> <td>See above.</td> </tr> <tr> <td>2</td> <td>-1.0 dB</td> <td>The edges are smoothed.</td> </tr> <tr> <td>3</td> <td>-3.0 dB</td> <td>-ditto-</td> </tr> <tr> <td>4</td> <td>-7.0 dB</td> <td>-ditto- (Factory setting)</td> </tr> <tr> <td>5</td> <td>-4.0 dB^{*1}</td> <td>3 pixels are smoothed in addition to the setting of 4.</td> </tr> </tbody> </table>	0	3.5 dB gain	The edges are enhanced.	1	1.0 dB gain	See above.	2	-1.0 dB	The edges are smoothed.	3	-3.0 dB	-ditto-	4	-7.0 dB	-ditto- (Factory setting)	5	-4.0 dB ^{*1}	3 pixels are smoothed in addition to the setting of 4.
0	3.5 dB gain	The edges are enhanced.																	
1	1.0 dB gain	See above.																	
2	-1.0 dB	The edges are smoothed.																	
3	-3.0 dB	-ditto-																	
4	-7.0 dB	-ditto- (Factory setting)																	
5	-4.0 dB ^{*1}	3 pixels are smoothed in addition to the setting of 4.																	

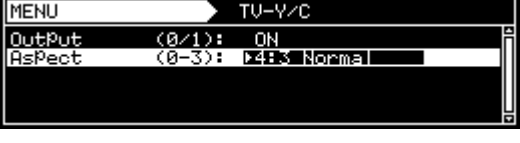
*1 The filter settings are common with the Y/C and SCART outputs.

4.8.3 Setting the ID signals (Y/C)

With the Y/C signals, identification of the aspect ratio is enabled by superimposing the ID DC signal onto the C signal.

Setting procedure

<p>(1) Select Program Edit using  or , and then press .</p>													
<p>(2) Select Output (TIM) using  or , and then press .</p>													
<p>(3) Select Analog Output using  or , and then press .</p>													
<p>(4) Select TV Y/C using  or , and then press .</p>													
<p>(5) Select Aspect using  or , and then press .</p>													
<p>(6) Select the setting using  or , and then press .</p> <p>Alternatively: Select the setting using the number keys ( to ) , and then press .</p>	<p>Set the DC voltage of the C signal.</p> <table border="1" data-bbox="746 1326 1375 1550"> <tbody> <tr> <td>0</td> <td>4:3 Normal</td> <td>4.3 (0 V)</td> </tr> <tr> <td>1</td> <td>4:3 Letter Box</td> <td>4:3 letter box (2.2 V)</td> </tr> <tr> <td>2</td> <td>16:9 Squeeze</td> <td>16:9 squeeze (5.0 V)</td> </tr> <tr> <td>3</td> <td>Auto</td> <td>The setting accords with the aspect ratio setting in the program.</td> </tr> </tbody> </table>	0	4:3 Normal	4.3 (0 V)	1	4:3 Letter Box	4:3 letter box (2.2 V)	2	16:9 Squeeze	16:9 squeeze (5.0 V)	3	Auto	The setting accords with the aspect ratio setting in the program.
0	4:3 Normal	4.3 (0 V)											
1	4:3 Letter Box	4:3 letter box (2.2 V)											
2	16:9 Squeeze	16:9 squeeze (5.0 V)											
3	Auto	The setting accords with the aspect ratio setting in the program.											
<p>Upon completion of the settings: Press .</p>	<p>Display returns to the initial screen.</p>												

4.8.4 Functions available with TV standard signals

Macrovision, closed caption, V-Chip, Teletext, WSS and CGMS-A/ID-1 can be multiplexed with the composite signals and Y signal.

For details on the setting procedure, refer to "5. FUNCTIONS AVAILABLE WITH TV STANDARD SIGNALS."

4.9 D5 (D connector)

4.9.1 Connectors and pin assignments

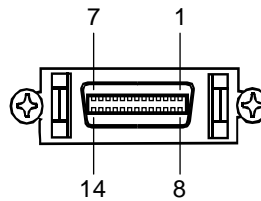













Pin no.	Signal	Pin no.	Signal
1	Y	8	Line 1
2	GND (Y)	9	Line 2
3	Pb	10	NC
4	GND (Pb)	11	Line 3
5	Pr	12	NC
6	GND (Pr)	13	NC
7	NC	14	NC

4.9.2 ID signals

ID signals indicating the resolution, scanning system and aspect ratio can be output from the D connector. The ID signals are DC signals, and they identify the formats using three lines. These lines are referred to as line 1, line 2 and line 3.

Setting procedure

(1)	<p>Select Program Edit using or , and then press .</p>	
(2)	<p>Select Output (TIM) using or , and then press .</p>	
(3)	<p>Select Analog Output using or , and then press .</p>	
(4)	<p>Select TV D5 using or , and then press .</p>	

(5)	<p><Selecting the items></p> <p>Select the items using  or  ,</p> <p>and then press .</p>	For further details on the setting items and parameters, refer to <Table of D5 setting items> below.
	<p><Setting the parameters></p> <p>Select the parameters using  or ,</p> <p>, and then press .</p> <p>Alternatively: Select the parameters using the number keys  , and then press .</p>	
	<p>Upon completion of the settings:</p> <p>Press .</p>	Display returns to the initial screen.

<Table of D5 setting items>

(1)	Line1 (0-2)	Line1: This sets the resolution.	
		0	480 720 × 480
		1	720 1280 × 720
		2	1080 1920 × 1080
		3	Auto The setting accords with the program setting.
(2)	Line2 (0/1)	Line2: This sets the scanning system.	
		0	Interlace Interlaced
		1	Progressive Progressive
		2	Auto The setting accords with the program setting.
(3)	Line3 (0-2)	Line3: This sets the aspect ratio.	
		0	4:3 4:3
		1	4:3 Letter Box 4:3 letter box
		2	16:9 16:9
		3	Auto The setting accords with the program setting.

4.10 VGA (D-Sub)

4.10.1 Connectors and pin assignments

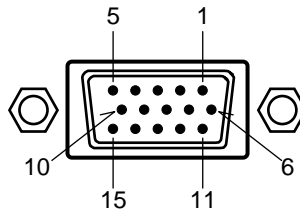

Pin no.	Signal	Pin no.	Signal
1	R	9	+5 V (DDC power supply *1)
2	G	10	GND
3	B	11	GND
4	NC	12	DDC DATA
5	NC	13	HS
6	GND (R)	14	VS
7	GND (G)	15	DDC CLK
8	GND (B)		

*1: Restrictions apply to the supply current of the DDC power supply. Refer to “12.3 Concerning the maximum current consumption of the DDC (DP_PWR) power supply.”

4.10.2 Video level settings

The setting procedure is the same as for the analog component signals.

Refer to “4.1.7 Setting the analog level” and “4.7.2 Setting the analog output connectors.”

4.10.3 Sync signal settings

The setting procedure is the same as for the analog component signals. Refer to “4.1.2 Setting the sync signals to ON or OFF and setting the sync signal polarities”

4.10.4 EDID

The operation procedure is the same as for HDMI. Refer to “6.13.3 EDID.”

4.10.5 DDC/CI

The operation procedure is the same as for DVI. Refer to “6.13.4 DDC/CI.”

4.11 SCART



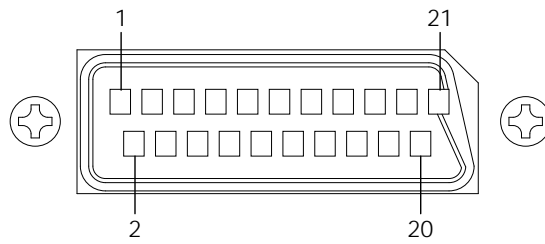



























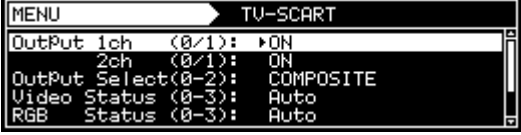

4.11.1 Connectors and pin assignments



Pin no.	Signal	Pin no.	Signal
1	Audio right channel output	11	Component G output
2	N.C.	12	N.C.
3	Audio left channel output	13	GND
4	GND	14	GND
5	GND	15	Component R output/C output
6	GND	16	RGB status
7	Component B output	17	GND
8	Video Status	18	GND
9	GND	19	Composite/Y output/CS
10	N.C.	20	N.C
		21	GND

4.11.2 SCART setting procedure

<SCART setting procedure>

<p>(1) Select Program Edit using  →  or  INC  DEC, and then press .</p>	 <pre> MENU Program Edit Program Name : ▶EIA1920x1080P60 Timing (TIM) Output (TIM) Audio (TIM) Pattern (PAT) </pre>
<p>(2) Select Output (TIM) using  or  INC  DEC, and then press .</p>	 <pre> MENU OutPut All OutPut Analog OutPut Digital OutPut VBI Function </pre>
<p>(3) Select Analog Output using  or  INC  DEC, and then press .</p>	 <pre> MENU Analog OutPut General PC: RGB (BNC) PC: UGA (D-Sub) PC: DVI TV: COMPOSITE </pre>
<p>(4) Select SCART using  or  INC  DEC, and then press .</p>	 <pre> MENU TV-SCART Output 1ch (0/1): ▶ON 2ch (0/1): ON Output Select(0-2): COMPOSITE Video Status (0-3): Auto RGB Status (0-3): Auto </pre>
<p>(5) Select the items using  or  INC  DEC, and then press .</p> <p><Inputting the parameters></p> <p>Select the parameters using  or  INC  DEC, and then press .</p> <p>Alternatively: Select the parameters using the number keys ( to ), and then press .</p>	<p>For further details on the parameters, refer to <SCART setting parameters>.</p>

<SCART setting parameters>

(1)	Output 1ch (0/1) Output 2ch (0/1)	This sets On or Off for each channel. The same settings as the ones described in "4.1.1 Setting the output interfaces to ON or OFF" can also be established.	
		0	Off No output.
		1	On Output.
(2)	Output Select (0-2)	This sets the format of the video signals which are output from the SCART connector.	
		0	COMPOSITE Composite signals are output.
		1	Y/C Y/C signals are output.
		2	RGB RGB signals are output.
(3)	Video Status (0-3)	This sets the video status signal which is output from the SCART connector.	
		0	Auto The setting accords with the program setting.
		1	4:3 4:3 (identified voltage: 12 V (9.5 to 12.0 V))
		2	16:9 16:9 (identified voltage: 5 V (4.5 to 7.0 V))
		3	No Signal No output. (identified voltage: 0 V (0.0 to 2.0 V))
(4)	RGB Status (0-3)	This sets the RGB status signal which is output from the SCART connector.	
		0	Auto The signal is set automatically by Output Select .
		1	VBS Composite or Y/C signals (identified voltage: 0 V)
		2	RGB RGB (identified voltage: 5 V)
		3	Fast Blanking The fast blanking signal is output.
(5)	Fast Blanking Area	This sets the output range of the fast blanking signal.	
		H	The horizontal output range is set as a percentage of H-Disp. Setting range: 0% to 100%
		V	The vertical output range is set as a percentage of V-Disp. Setting range: 0% to 100%
(6)	Audio Out1ch (0/1)	This sets on or off for each channel.	
		0	OFF No output.
		1	ON Output.
(7)	Audio Out2ch (0/1)	This setting is the same as for the Audio Out1ch setting.	

4.11.3 Functions available with TV standard signals

Macrovision, closed caption, V-Chip, Teletext, WSS and CGMS-A/ID-1 can be multiplexed with the composite signals and Y signal.

For details on the setting procedure, refer to "5. FUNCTIONS AVAILABLE WITH TV STANDARD SIGNALS."

4.11.4 Filter settings

For further details on the setting procedure, refer to "4.8.2 Composite signal filter settings."

4.11.5 Concerning the fast blanking signal

The fast blanking signal is a control signal for selecting the composite output and RGB output video signals which are output from the 16-pin SCART connector, and displaying them. By using it, displays can be shown as with on-screen displays. When the fast blanking signal level is low (0 V), the CVBS video signals are displayed on the monitor; when it is high (5 V), the RGB video signals are displayed.

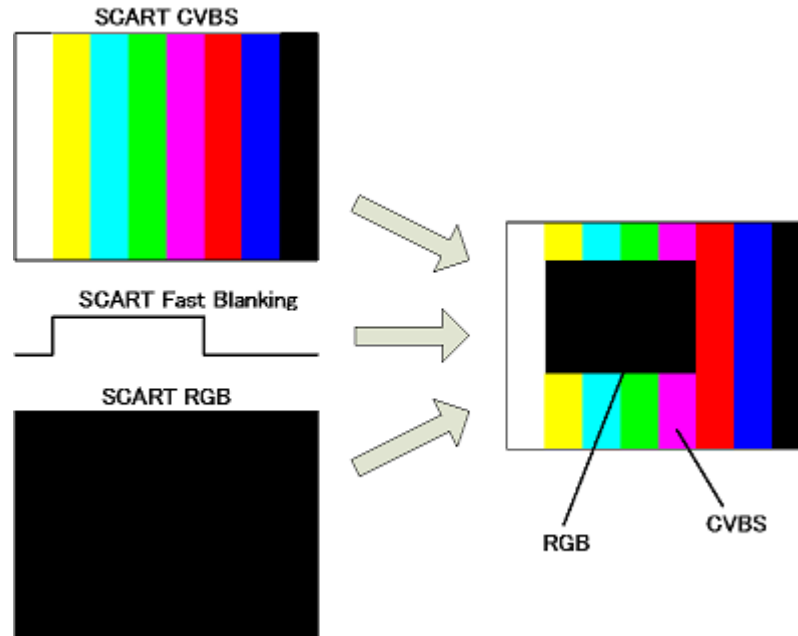

- With the VG-870B/871B/873/874 can not output different images from the composite and RGB output pins of the SCART connector. If COMPOSITE or Y/C has been set for "Output Select" in the SCART setting, a black-filled image is output to the RGB output, if RGB has been set, the same image as the composite pin is output.

4.11.6 Audio settings

For details on the setting procedure, refer to "4.15 Analog audio settings."

4.12 DisplayPort / eDP

4.12.1 Connectors and pin assignments

■ DisplayPort

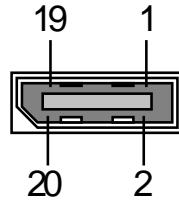

Pin No.	Signal
1	MainLink Lane0 (p)
2	GND
3	MainLink Lane0 (n)
4	MainLink Lane1 (p)
5	GND
6	MainLink Lane1 (n)
7	MainLink Lane2 (p)
8	GND
9	MainLink Lane2 (n)
10	MainLink Lane3 (p)
11	GND
12	MainLink Lane3 (n)
13	GND
14	GND
15	AUX CH (p)
16	GND
17	AUX CH (n)
18	Hot Plug Detect
19	PWR_Return (not used)
20	DP_PWR (+3.3 V)

* The DDC power supply current is limited. Refer to “**12.3 Concerning the maximum current consumption of the DDC (DP_PWR) power supply.**”

■ eDP Control Signal + Power OUT (Connector : HIROSE Electric DX10G1M-50SE)

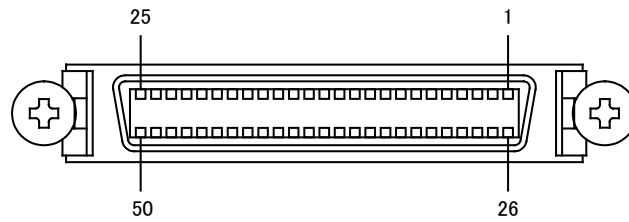





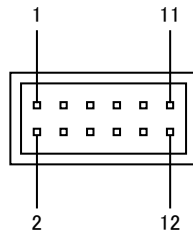



















Pin No.	Signal	Pin No.	Signal
1	GND	26	GND
2	GPIO OUT7	27	GPIO OUT6
3	GPIO OUT5	28	GPIO OUT4
4	GPIO OUT3	29	GPIO OUT2
5	GPIO OUT1	30	GPIO OUT0
6	3.3V OUT	31	GND
7	3.3V OUT	32	GND
8	3.3V OUT	33	GND
9	5V OUT	34	GND
10	5V OUT	35	GND
11	5V OUT	36	GND
12	GND	37	GND
13	GND	38	GND
14	GND	39	GND
15	External Power OUT2	40	External Power OUT2
16	External Power OUT2	41	External Power OUT2
17	External Power OUT2	42	External Power OUT2
18	GND	43	GND
19	GND	44	GND
20	GND	45	GND
21	External Power OUT1	46	External Power OUT1
22	External Power OUT1	47	External Power OUT1
23	External Power OUT1	48	External Power OUT1
24	GND(RS-232C)	49	GND(RS-232C)
25	RXD(RS-232C)	50	TXD(RS-232C)

■ eDP External Power IN (Connector: HIROSE Electric DF1BZ-12DP-2.5DS)



Pin No.	Signal
1	External Power IN2
2	GND
3	External Power IN2
4	GND
5	External Power IN2
6	GND
7	External Power IN1
8	GND
9	External Power IN1
10	GND
11	External Power IN1
12	GND

4.12.2 DisplayPort setting procedure

(1)	<p>Select Program Edit using  or , and then press .</p>	
(2)	<p>Select Output (TIM) using  or , and then press .</p>	
(3)	<p>Select Digital Output using  or , and then press .</p>	
(4)	<p>Select DP using  or , and then press .</p>	
(5)	<p>Select the items using  or , and then press .</p> <p><Inputting the parameters></p> <p>Select the parameters using  or , and then press .</p> <p>Alternatively: Select the parameters using the number keys ( to ) , and then press .</p>	<p>For further details on the parameters, refer to <DP unit setting parameters>.</p>

<DP unit setting parameters>

(1)	Output 1ch (0/1) Output 2ch (0/1)	This sets On or Off for each channel. The same settings as the ones described in “4.1.1 Setting the output interfaces to ON or OFF” can also be established.	
		0	OFF No output.
		1	ON Output.
(2)	Audio Output (0/1)	Set Embedded Audio output. * Refer to “4.12.5 Embedded Audio” about its setting.	
		0	OFF Embedded audio is not output.
		1	ON Embedded audio is output.
(3)	Mode (0-2)	This sets the drawing mode. For further details, refer to “b) Concerning the drawing mode” in this section.	
		0	Single Output in Single mode.
		1	Dual Output in Dual mode.
		2	Split Output in Split mode. Note) the function is different between VM-1820(A) and VM-1826. Refer to “(b) Concerning drawing mode” in this section for details.
(4)	Split (0/1)	This selects screen split mode for 4Kx2K timing. This item is available only for VM-1826.	
		0	Horizontally Horizontally split into 2.
		1	Vertically Vertically split into 2.
(5)	Video Format (0-2)	This sets the color space of the video output from DisplayPort. * When the YCbCr4:2:2 format has been selected, it is not possible to display the gray scale which has been set. Use this parameter to check the Main Stream Attribute parameters only.	
		0	RGB The video is output using RGB signals.
		1	YCbCr4:4:4 The video is output using YCbCr4:4:4 signals.
		2	YCbCr4:2:2 The video is output using YCbCr4:2:2 signals.
(6)	Width (0-4)	This sets the bit length of the output video. A setting independent of the bit length for pattern drawing can be selected, or the same bit length can be selected automatically. * The portion of the bit length for pattern drawing exceeds the bit length set here is discarded. Any deficient portion is filled with zeros. Refer to “4.1.5 Setting the bit length (gray scale) for pattern drawing” * The bit length setting differs according to the video format. For further details, refer to “(c) Concerning the bit length setting” in this section. * For further details on the bit length to be output, refer to “(c) Concerning the bit length setting” in this section.	
		0	Auto 6, 8, 10 or 12 bits are selected here automatically depending on the bit length for pattern drawing.
		1	6bit 6-bit output
		2	8bit 8-bit output
		3	10bit 10-bit output
		4	12bit 12-bit output Note: this item can be selected in case of Video Format = 2 (YCbCr4:2:2). Refer to “(c) About bit length” for details.
(7)	Colorimetry (0/1)	This selects the Main Stream Attribute “YCbCr Colorimetry”. * This sets only the Main Stream Attribute. To change the color difference coefficient setting, refer to “4.1.6 Selecting RGB or YPbPr and setting the color difference coefficients”.	
		0	ITU601 This sets ITU-R BT601.
		1	ITU709 This sets ITU-R BT709.
(8)	Link Set Mode (0/1)	This selects the Link Rate and Number of Lane setting method.	
		0	Auto Output accords with the DPCD of the sink component.

		1	Manual	Output accords with the settings of items (7) and (8).
(9)	Link Rate (0/1)	* This parameter can be set when Link Set Mode is “Manual”. This sets the link rate.		
		0	HBR(2.7Gbps)	Output at the link rate “HBR (2.7 Gbps)”
		1	RBR(1.62Gbps)	Output at the link rate “RBR (1.62 Gbps)”
(10)	Number of Lane (0-2)	* This parameter can be set when the Link Set Mode is “Manual”. This sets the number of output lanes.		
		0	1lane	Output on 1 lane
		1	2lanes	Output on 2 lanes
		2	4lanes	Output on 4 lanes
(11)	SSC (0/1)	This sets SSC (Spread Spectrum Clock). Note) This item is displayed only for the unit with VM-1820A or VM-1826. Default setting is Enable.		
		0	Disable	SSC is not valid
		1	Enable	SSC is Valid (Default)
(12)	Nvid	1-1667216		This sets the Nvid value. * The Mvid value is automatically calculated from the dot clock and the Nvid value.
(13)	HPD Mode (0/1)	This sets the Hotplug detection status.		
		0	OFF	Hotplug is ignored.
		1	ON	Hotplug is judged according to the status of the connected component.
(14)	InfoFrame			













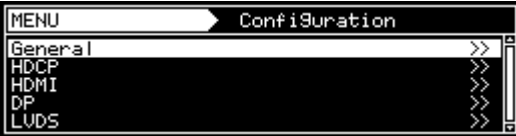

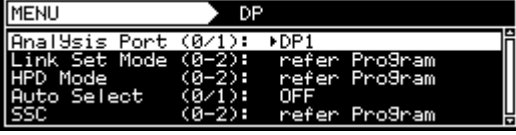

a) Concerning the all program fixed setting

The “program setting” for the following setting items can be ignored and output can be performed with the entire program fixed according to the “device config setting”. For example, this is used to set an entire sample program to HPD mode OFF, or to change the output video bit length but leave other settings unchanged, etc.

Parameters which can be set to program fixed

Item	Remarks
Width	Refer to “4.1.5 Setting the bit length (gray scale) for pattern drawing.”
Link Set Mode	See below.
HPD Mode	
InfoFrame	
SSC	

Follow the procedure below to set Link Set Mode and HPD Mode.

<p>(1) Select Configuration using  or , and then press .</p>	
<p>(2) Select DP using  or , and then select .</p>	
<p>(3) Select the items using  or , and then press .</p> <p><Inputting the parameters></p> <p>Select the parameters using  or , , and then press .</p> <p>Alternatively: Select the parameters using the number keys ( to ) , and then press .</p>	<p>For further details on the parameters, refer to <Program fixed setting parameters>.</p>

<Program fixed setting parameters>

(1)	Link Set Mode (0-2)	This selects the Link Set Mode setting method. For further details, refer to "<DP unit setting parameters> 'Link Set Mode'" in this section.		
		0	refer Program	The setting accords with the program setting.
		1	Auto	Output always accords with the DPCD of the sink component.
		2	Manual	Output always accords with the Link Rate and Number of Lane set by the program.
(2)	HPD Mode (0-2)	This selects the Hotplug detection method. For further details, refer to "<DP unit setting parameters> 'HPD Mode'" in this section.		
		0	refer Program	The setting accords with the program setting.
		1	OFF	Hotplug is always ignored.
		2	ON	Hotplug is always judged according to the status of the connected component.
(3)	Auto Select (0/1)	This selects InfoFrame sending method. Refer to 4.12.9 InfoFrame.		
(4)	SSC (0-2)	This selects SSC (Spread Spectrum Clock) setting.		
		0	Refer Program	Follow program setting
		1	Disable	SSC is always not valid.
		2	Enable	SSC is always valid.

b) Concerning the drawing mode

The following video output modes are possible using the two DisplayPort output ports.

The examples below describe the case for 1280 × 1024 resolution, a 108 MHz dot clock, with 10-bit output level.

(1) Single mode

This is the normal output mode. The same video is output from both Port1 and Port2.

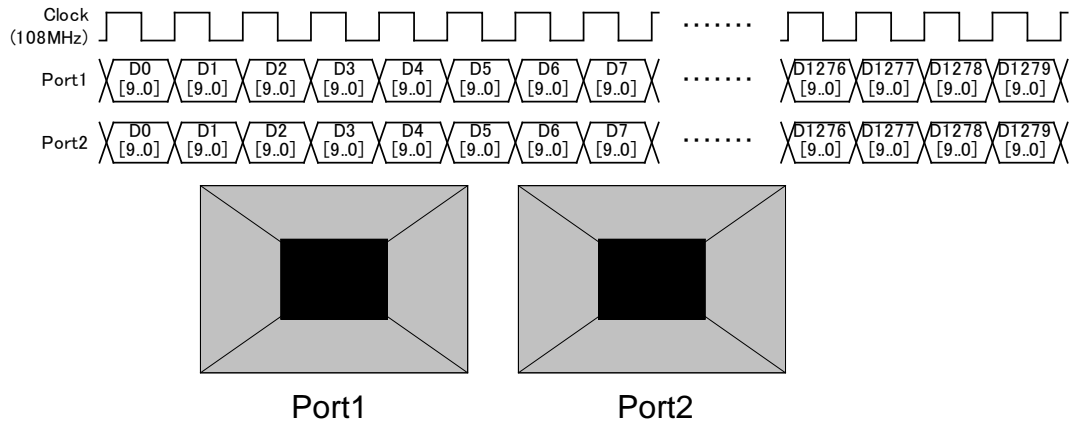

(2) Dual mode

The video data is output alternately from Port1 and Port2.

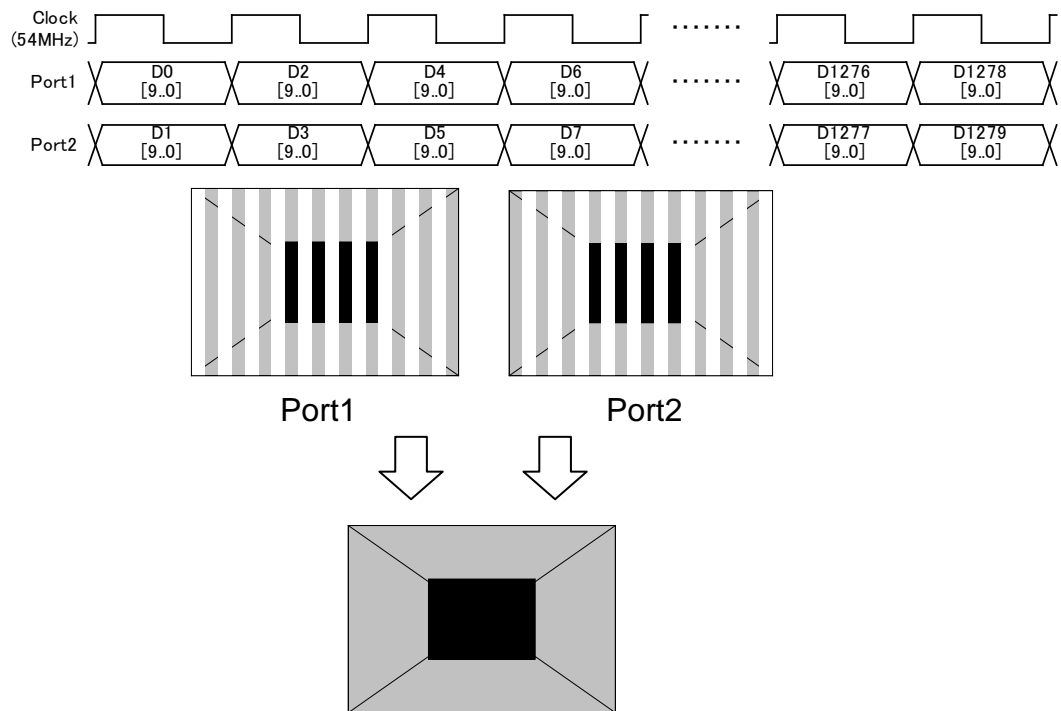

(3) Split mode

The left half of the video data is output from Port1, and the right half of the video data from Port2.

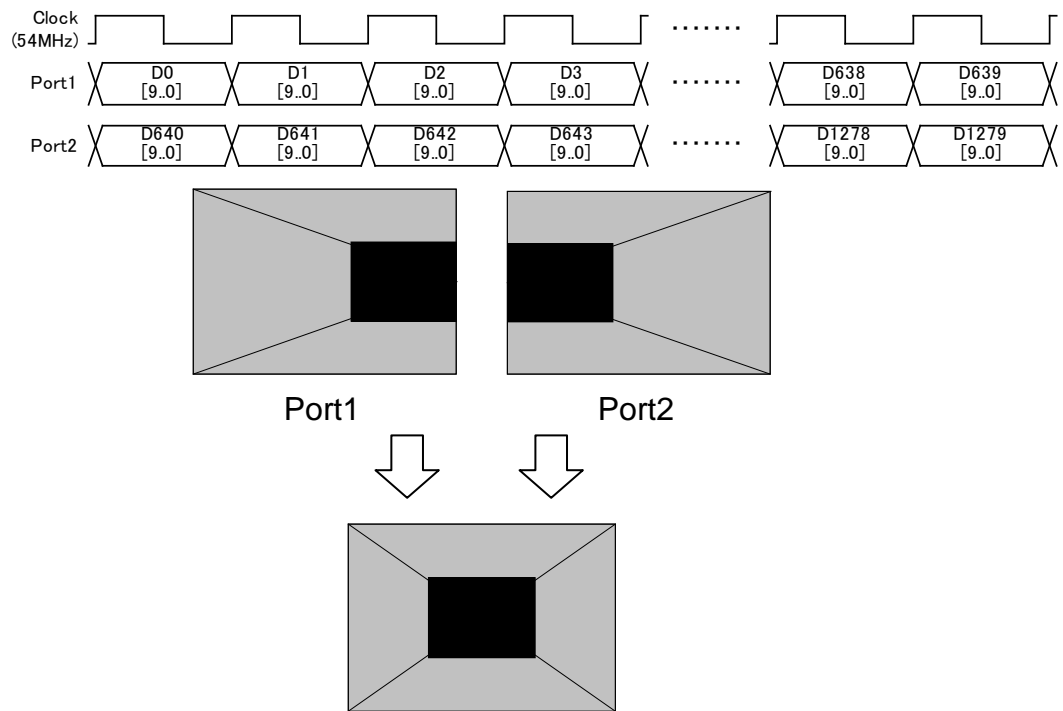
**(4) Split Mode (VM-1826) - Horizontally***

Port1 outputs upper half, and Port2 outputs bottom half.

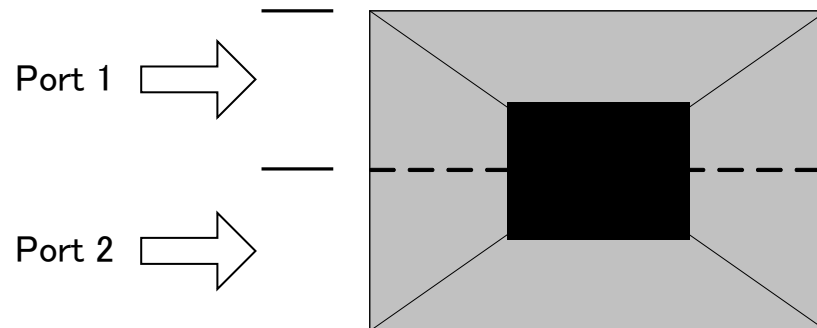

(5) Split Mode (VM-1826) - Vertically *

Port1 outputs left half. Ports 2 outputs right half.

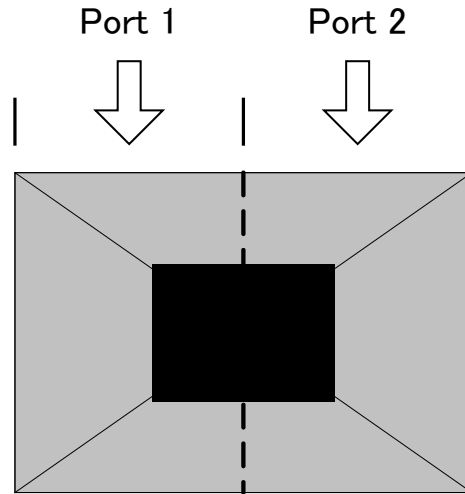

*** Note) Split mode (4Kx2K support) of VM-1826 is option.**

c) Concerning the bit length setting

The valid bit length settings differ according to the video format as follows.

Video Format	bit Width			
	6bit	8bit	10bit	12bit
RGB	○	((X
YCbCr4:2:2	((((
YCbCr4:4:4	(((X

Caution: When the YCbCr4:2:2 format has been selected, up to 12 bits can be set as the bit length. However, it is not possible to display the gray scale which is set in the “bit length (step)”. Use this parameter to check the Main Stream Attribute parameters rather than using it to check the image quality.

d) Concerning the Main Stream Attribute settings











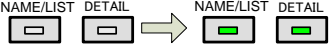

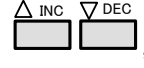

The Main Stream Attributes used for DisplayPort transfer are reflected by the following settings.

Item		Setting location
M and N for stream clock recovery	Mvid	This is automatically calculated from the Nvid setting value and the dot clock. (The VG-870B/871B/873/874 is fixed to asynchronous mode, so the Mvid value varies.)
	Nvid	The setting is followed by the DisplayPort setting "Nvid". Refer to "<DP unit setting parameters>" in this section.
Horizontal/Vertical Timing	Total Active start Active video width Sync width	This is calculated from the value set by the Timing setting. For further details, refer to "Timing setting".
	polarity	The setting is followed by the sync signal polarity set by the Output setting. For further details, refer to "4.1.2 Setting the sync signals to ON or OFF and setting the sync signal polarities"
Miscellaneous0	Synchronous Clock	The VG-870B/871B/873/874 are fixed to asynchronous mode.
	Component format	The setting is followed by the DisplayPort setting "Video Format". Refer to "<DP unit setting parameters>" in this section. Full: VESA range Limited: CEA range
	Dynamic range	The setting is followed by the Output setting "Level Mode". For further details, refer to "4.1.3 Setting the level mode".
	YCbCr Colorimetry	The setting is followed by the DisplayPort setting "Colorimetry". Refer to "<DP unit setting parameters>" in this section.
	Bit depth per color component	The setting is followed by the DisplayPort setting "Width". Refer to "<DP unit setting parameters>" in this section.
Other	Settings except above are not supported by the VG-870B/871B/873/874.	

4.12.3 Displaying the DisplayPort setting information

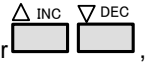







The DisplayPort setting information (Link Rate, Number of Lane, Link training results, DPCD) can be displayed.

a) DisplayPort setting display procedure

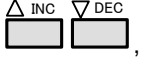
<p>(1) </p>	
<p>(2) < Displaying DP > Select DP or DP(HEX) on the second page using  or , and then press .</p> <p>Alternatively: Select  for the GUI display format, or  for the HEX display format.</p>	<p>DP is displayed as shown in the figure below.</p>  <p>DP: Setting display information, DPCD (GUI display format) DP(HEX): DPCD (HEX display format) For further details, refer to “c) Display contents.”</p>
<p>(3) <Switching the pages> Select  (previous page) or  (next page) using  or , and then press .</p> <p>Alternatively: Select the page using  (previous page) or  (next page).</p>	<p>When the display extends over multiple pages, it is divided up and shown on the fluorescent display tube. (Switch the page to display all the information.)</p>

b) Selecting the port whose result is displayed

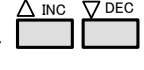
Select the port for which the setting information is to be displayed.

<p>(1) </p> <p>Select either DP or DP(HEX).</p>							
<p>(2) Select EDIT using  or , and then press .</p> <p>Alternatively: Select EDIT using .</p>							
<p>(3) <Selecting the port> Select the port using  or , and then press .</p>	<p>This selects the port for which the DisplayPort setting information is to be displayed.</p> <table border="1" data-bbox="742 1915 1399 2011"> <tr> <td>0</td> <td>DP1</td> <td>This selects DisplayPort1.</td> </tr> <tr> <td>1</td> <td>DP2</td> <td>This selects DisplayPort2.</td> </tr> </table>	0	DP1	This selects DisplayPort1.	1	DP2	This selects DisplayPort2.
0	DP1	This selects DisplayPort1.					
1	DP2	This selects DisplayPort2.					

c) Setting contents

Displayed information

(1) Setting display information (GUI page 1)

This page displays the DisplayPort interface settings (Link Rate, Number of Lane, Main Stream Attribute) and the link training results.

(1) → DisplayPort Infomation (DP1)

(2) → LinkRate : 2.7Gbps

(3) → Lane Count : 4 lanes

(4) → -----MainStreamAttribute-----

M(at a certain time) : 3054
N : 32768

	H(dot)	V(line)
Total	800	525
Active Start	144	35
Active	640	480
Sync	96	2
Pol	NEGA	NEGA

SynchronousClock : Asynchronous
Component Format : RGB
Dynamic Range : VESARange
YCbCr Colorimetry : ITU601
Bit Depth per Color/Component : 8 bits
Interlaced vertical total : ODD

	LANE0	LANE1	LANE2	LANE3
Clock Recovery	PASS	PASS	PASS	PASS
Channel EQ	PASS	PASS	PASS	PASS
Voltage Swing	0.4V	0.4V	0.4V	0.4V
Pre-emphasis	6.0dB	6.0dB	6.0dB	6.0dB

(5) → [Link training results for LANE0-3]

(6) → [Voltage Swing and Pre-emphasis for each lane]

Details of the displayed information are as follows.

(1)	This is the port for which the setting status is displayed.
(2)	Link Rate setting value
(3)	Number of lane setting value
(4)	Main Stream Attribute (Only supported values are displayed.) * The Mvid value actually varies, but the value at the time of this display setting is displayed.
(5)	Link training results (clock recovery, channel equalizer) for each lane
(6)	Voltage swing and pre-emphasis for each lane

(2) DPCD display (GUI page 2 and onward, HEX is DPCD display only)

These pages display the DPCD (DisplayPort Configuration Data). The data for different addresses can be displayed by switching the page.

```

(1)
===DPCD:ReceiverCapabilityField[Port=DP1]
00000 | DPCD_REV:11h
      | DPCD_REV=1.1
00001 | MAX_LINK_RATE:0Ah
      | MAX_LINK_RATE=2.7Gbps
00002 | MAX_LANE_COUNT:84h
      | MAX_LANE_COUNT=4,ENHANCED_FRAME_GAP=1
00003 | MAX_DOWNSPREAD:00h
      | MAX_DOWNSPREAD=0,NO_AUX_HANDSHAKE_LINK_TRAINING=0
00004 | NORP:00h
      | NORP = 0
00005 | DWN_STREAM_PORT_PRESENT:00h
      | DWN_STREAM_PORT_PRESENT=0,DWN_STREAM_PORT_TYPE=DisplayPort
      | FORMAT_CONVERSION=0
00006 | MAIN_LINK_CHANNEL_CODING:00h
      | MAIN_LINK_CHANNEL_CODING=---
00007 | DWN_STREAM_PORT_COUNT:00h
      | DWN_STREAM_PORT_COUNT=0,OUISupport=notsupported
00008 | RECEIVE_PORT0_CAP0:00h
      | LOCAL_EDID_PRESENT=0,ASSOCIATED_TO_PRECEDING_PORT=0
00009 | RECEIVE_PORT0_CAP1:00h
      | BUFFER_SIZE=32byte/lane
0000A | RECEIVE_PORT1_CAP0:00h
      | LOCAL_EDID_PRESENT=0,ASSOCIATED_TO_PRECEDING_PORT=0
0000B | RECEIVE_PORT1_CAP1:00h
      | BUFFER_SIZE=32byte/lane
(2) (3)

```

DPCD display (GUI)

```

(1)
===DPCD:ReceiverCapabilityField[Port=DP1]
00 01 02 03 04 05 06 07 08 09 0A 0B 0C 0D 0E 0F
00 11 0A 84 00 00 00 00 00 00 00 00 00 00 00 00
10 00 00 00 00 00 00 00 00 00 00 00 00 00 00 00
20 00 00 00 00 00 00 00 00 00 00 00 00 00 00 00
30 00 00 00 00 00 00 00 00 00 00 00 00 00 00 00
40 00 00 00 00 00 00 00 00 00 00 00 00 00 00 00
50 00 00 00 00 00 00 00 00 00 00 00 00 00 00 00
60 00 00 00 00 00 00 00 00 00 00 00 00 00 00 00
70 00 00 00 00 00 00 00 00 00 00 00 00 00 00 00
80 00 00 00 00 00 00 00 00 00 00 00 00 00 00 00
90 00 00 00 00 00 00 00 00 00 00 00 00 00 00 00
A0 00 00 00 00 00 00 00 00 00 00 00 00 00 00 00
B0 00 00 00 00 00 00 00 00 00 00 00 00 00 00 00
C0 00 00 00 00 00 00 00 00 00 00 00 00 00 00 00
D0 00 00 00 00 00 00 00 00 00 00 00 00 00 00 00
E0 00 00 00 00 00 00 00 00 00 00 00 00 00 00 00
F0 00 00 00 00 00 00 00 00 00 00 00 00 00 00 00
(4)

```

DPCD display (HEX)

Details of the displayed information are as follows.

















(1)	Port and DPCD field for which the setting status is displayed.
(2)	DPCD address
(3)	Setting values for each parameter
(4)	HEX display

4.12.4 DisplayPort Analysis

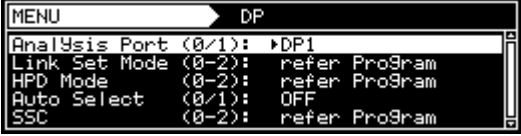
The DisplayPort Analysis mode is used to perform the link check evaluation and otherwise evaluate the DisplayPort interface.

















a) Setting the port to be used

Select the port to be used by DisplayPort Analysis with the device settings.

<p>(1) Select Configuration using    or  , and then press .</p>							
<p>(2) Select DP using  or  , and then press .</p>							
<p>(3) Select the Analysis Port using  or  , and then press   .</p>	<p>This selects the port to be used by DisplayPort Analysis.</p> <table border="1" data-bbox="863 862 1495 949"> <tr> <td>0</td> <td>DP1</td> <td>DP1 is used.</td> </tr> <tr> <td>1</td> <td>DP2</td> <td>DP2 is used.</td> </tr> </table>	0	DP1	DP1 is used.	1	DP2	DP2 is used.
0	DP1	DP1 is used.					
1	DP2	DP2 is used.					

b) I/F Check mode

This mode performs a simple check on the DisplayPort interface. This makes it possible to check link training, Hotplug detection (cable connection/disconnection) and other behavior without creating a program.

<p>(1) Select DP Analysis using    or  , and then press .</p>	
<p>(2) Select I/F Check, and then press .</p>	
<p>(3) <Selecting each function> Select the functions using , and then press .</p> <p>Alternatively: Select the functions using the number keys (  to  ), and then press .</p>	<p>For further details on each function, refer to <I/F Check mode setting parameters> in this section.</p>

</F Check mode setting parameters>

The following functions are available in I/F Check mode.

Page	Number key	Item	Description
1/2	7	LT	Link training is performed each time this key is pressed.
	8	Hotplug	This switches the Hotplug status.
			Detect The current connected status is judged.
			Negate The Hotplug status is forcibly set to the Negate status. (*1).
	9	PW SAVE	This makes the power save mode setting for the connected component.
	4	VID_MUTE	This sets Video MUTE to On or Off. (*2)
5	AUD_MUTE	This sets Audio MUTE to On or Off. (*2)	
	0	EDIT	This enters the DisplayPort output setting menu.
2/2	7	DEFAULT	This returns to the currently selected program pattern.
	8	LIST	This displays the DisplayPort display screen GUI (refer to "4.12.3 Displaying the DisplayPort setting information").
	9	EDID	This reads the EDID of the connected component. This is the same operation as the normal EDID Read operation.
	0	EDIT	This enters the DisplayPort output setting menu.

When Page 1 is displayed, the following Hotplug statuses are shown.

Item	Description
Port	This displays the port to be used by the "DisplayPort Analysis" set by the device settings.
HPD Mode	This displays the HPD mode set by the DisplayPort output settings.
Status	This displays the Hotplug status.
	ASSERT Hotplug is asserted.
	NEGATE Hotplug is negated.
	- - HPD mode is OFF. (The Hotplug status is not judged.)

*1 Concerning the Hotplug Negate setting

The Hotplug signal is used by the sink component to notify its status to the source component. This function performs processing to forcibly set the Negate status (cable disconnected status) on the VG-870B/871B/873/874 side.

This function can be used to check sink component operation with respect to the initial operation of the source component (the VG-870B/871B/873/874), without disconnecting and connecting the cable.

*2 Concerning the VID_MUTE and AUD_MUTE settings

The VID_MUTE setting is active only for the "Port" which was selected as the Configuration setting.











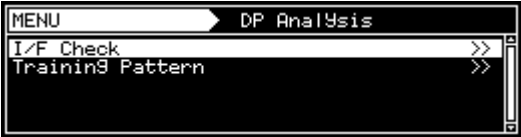

The AUD_MUTE setting is set for both Port 1 and Port 2.

*3 The first page of the DisplayPort display screen GUI (refer to "4.12.3 Displaying the DisplayPort setting information") is shown when link training is restarted, such as when the LT key is pressed, the Hotplug detection is performed again, or operation recovers from power save mode, etc.

c) Training Pattern mode

This mode optionally outputs the “D10.2 pattern”, “PRBS-7 pattern” and other training patterns used to check DisplayPort interface conformance during link training, etc.

- * These patterns are not video patterns, and are instead patterns used for evaluation on the DisplayPort interface. Therefore, non-DisplayPort output and DisplayPort output that is not selected by “a) Setting the port to be used” remain as the video output displayed thus far.

(1)	<p>Select DP Analysis using  or  or  , and then press .</p>	
(2)	<p>Select Training Pattern, and then press .</p>	
(3)	<p><Selecting each function></p> <p>Select the functions using , and then press .</p> <p>Alternatively: Select the functions using the number keys ( to ) , and then press .</p>	<p>For further details on each function, refer to <Training Pattern mode setting parameters> in this section.</p>

<Training Pattern mode setting parameters>

The following settings can be made in Training Pattern mode.

(1)	Pattern Select (0-3)	<p>This sets the pattern.</p> <table border="1"> <tr> <td data-bbox="663 1167 695 1211">0</td> <td data-bbox="695 1167 967 1211">D10.2 (TP1)</td> <td data-bbox="967 1167 1497 1211">The D10.2 test pattern (Link Training Pattern1) is output.</td> </tr> <tr> <td data-bbox="663 1211 695 1256">1</td> <td data-bbox="695 1211 967 1256">EQ (TP2)</td> <td data-bbox="967 1211 1497 1256">The Link Training Pattern2 (Channel Equalization Sequence) is output.</td> </tr> <tr> <td data-bbox="663 1256 695 1402">2</td> <td data-bbox="695 1256 967 1402">Symbol Error Rate</td> <td data-bbox="967 1256 1497 1402">The Symbol Error Rate Measurement Pattern is output. (This pattern is output only, and the error rate is not measured.)</td> </tr> <tr> <td data-bbox="663 1402 695 1442">3</td> <td data-bbox="695 1402 967 1442">PRBS7</td> <td data-bbox="967 1402 1497 1442">The PRBS7 pattern is output.</td> </tr> </table>	0	D10.2 (TP1)	The D10.2 test pattern (Link Training Pattern1) is output.	1	EQ (TP2)	The Link Training Pattern2 (Channel Equalization Sequence) is output.	2	Symbol Error Rate	The Symbol Error Rate Measurement Pattern is output. (This pattern is output only, and the error rate is not measured.)	3	PRBS7	The PRBS7 pattern is output.
0	D10.2 (TP1)	The D10.2 test pattern (Link Training Pattern1) is output.												
1	EQ (TP2)	The Link Training Pattern2 (Channel Equalization Sequence) is output.												
2	Symbol Error Rate	The Symbol Error Rate Measurement Pattern is output. (This pattern is output only, and the error rate is not measured.)												
3	PRBS7	The PRBS7 pattern is output.												
(2)	Link Rate (0/1)	<p>This sets the link rate.</p> <table border="1"> <tr> <td data-bbox="663 1476 695 1520">0</td> <td data-bbox="695 1476 967 1520">HBR (2.7Gbps)</td> <td data-bbox="967 1476 1497 1520">Output at the link rate “HBR (2.7 Gbps)”.</td> </tr> <tr> <td data-bbox="663 1520 695 1543">1</td> <td data-bbox="695 1520 967 1543">RBR (1.62Gbps)</td> <td data-bbox="967 1520 1497 1543">Output at the link rate “RBR (1.62 Gbps)”.</td> </tr> </table>	0	HBR (2.7Gbps)	Output at the link rate “HBR (2.7 Gbps)”.	1	RBR (1.62Gbps)	Output at the link rate “RBR (1.62 Gbps)”.						
0	HBR (2.7Gbps)	Output at the link rate “HBR (2.7 Gbps)”.												
1	RBR (1.62Gbps)	Output at the link rate “RBR (1.62 Gbps)”.												
(3)	Number of Lane (0-2)	<p>This sets the number of output lanes.</p> <table border="1"> <tr> <td data-bbox="663 1576 695 1621">0</td> <td data-bbox="695 1576 967 1621">1lane</td> <td data-bbox="967 1576 1497 1621">Output on 1 lane.</td> </tr> <tr> <td data-bbox="663 1621 695 1666">1</td> <td data-bbox="695 1621 967 1666">2lanes</td> <td data-bbox="967 1621 1497 1666">Output on 2 lanes.</td> </tr> <tr> <td data-bbox="663 1666 695 1680">2</td> <td data-bbox="695 1666 967 1680">4lanes</td> <td data-bbox="967 1666 1497 1680">Output on 4 lanes.</td> </tr> </table>	0	1lane	Output on 1 lane.	1	2lanes	Output on 2 lanes.	2	4lanes	Output on 4 lanes.			
0	1lane	Output on 1 lane.												
1	2lanes	Output on 2 lanes.												
2	4lanes	Output on 4 lanes.												

(4)	Voltage Swing (0-3)	This sets the voltage swing level (differential level).		
		0	0.4 V	Output at 0.4 V
		1	0.6 V	Output at 0.6 V
		2	0.8 V	Output at 0.8 V
		3	1.2 V	Output at 1.2 V
(5)	Pre-emphasis (0-3)	This sets the pre-emphasis level.		
		0	0 dB	Output at 0 dB
		1	3.5 dB	Output at 3.5 dB
		2	6.0 dB	Output at 6.0 dB
		3	9.5 dB	Output at 9.5 dB

- * The Training Pattern mode settings can be made only for the Main Link output. DPCD and other settings in accordance with each pattern and level are not made.
- * When returning from Training Pattern mode to normal output, the settings return to the program settings selected thus far.
- * The valid voltage swing level setting and pre-emphasis setting combinations are as follows.















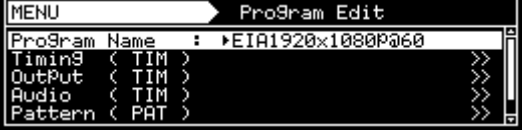









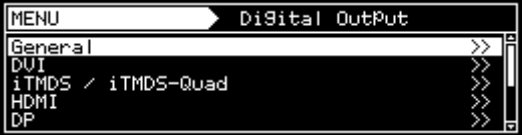

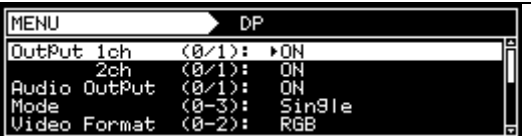

Voltage Swing	Pre-emphasis			
	0 dB	3.5 dB	6 dB	9.5 dB
0.4 V	○	○	○	○
0.6 V	○	○	○	×
0.8 V	○	○	×	×
1.2 V	○	×	×	×

4.12.5 Embedded audio

Embedded audio signals can be output from the DisplayPort.

- Set embedded audio to be imposed on DisplayPort enable.
- Set audio source, frequency and level.

a) Set embedded audio to be imposed on DisplayPort enable.

<p>① By using  →  or   , Select Program Edit → </p>	 <pre> MENU Program Edit Program Name : ▶EIA1920x1080P@60 Timing < TIM > Output < TIM > Audio < TIM > Pattern < PAT > </pre>						
<p>② By using  or   , Select Output (TIM) → </p>	 <pre> MENU OutPut All OutPut Analog OutPut Digital OutPut VBI Function </pre>						
<p>③ By using  or   , Select Digital Output → </p>	 <pre> MENU Digital OutPut General DUI iTMD5 / iTMD5-Quad HDMI DP </pre>						
<p>④ By using  or   , Select DisplayPort → </p>	 <pre> MENU DP OutPut 1ch (0/1): ▶ON 2ch (0/1): ON Audio OutPut (0/1): ON Mode (0-3): Single Video Format (0-2): RGB </pre>						
<p>⑤ By using  or   , Select Audio Output → </p> <p>By using  or   , Select  or  .</p>	 <pre> MENU DP OutPut 1ch (0/1): ON 2ch (0/1): ON Audio OutPut (0/1): ▶ON Mode (0-3): Single Video Format (0-2): RGB </pre> <table border="1" data-bbox="911 1361 1476 1449"> <tbody> <tr> <td>0</td> <td>OFF</td> <td>Invalid</td> </tr> <tr> <td>1</td> <td>ON</td> <td>Valid</td> </tr> </tbody> </table>	0	OFF	Invalid	1	ON	Valid
0	OFF	Invalid					
1	ON	Valid					

b) Set audio source, frequency and level.

Refer to “4.16 Digital Audio”.

4.12.6 EDID

For further details on the setting procedure, refer to “6.13.3 EDID”.

4.12.7 HDCP

For further details on the setting procedure, refer to “8.1 HDCP settings”.

4.12.8 DDC/CI

















For further details on the setting procedure, refer to “6.13.4 DDC/CI”.

4.12.9 Info Frame

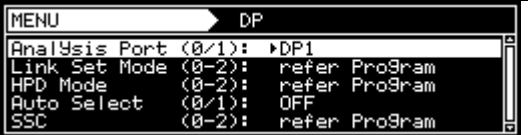
InfoFrame can be set by either method of below items.

- a) Send appropriate InfoFrame automatically.
- b) Set each value of InfoFrame independently.

a) Send appropriate InfoFrame automatically.

<p>①</p> <p>By using  →  or  ,</p> <p>Select Configuration → </p>										
<p>②</p> <p>By using  or  ,</p> <p>Select DP → </p>										
<p>③</p> <p>By using  or  ,</p> <p>Select Auto Select →  → </p>	<table border="1"> <thead> <tr> <th colspan="3">Select automatic transmission</th> </tr> </thead> <tbody> <tr> <td>0</td> <td>OFF</td> <td>Does not send appropriate value automatically.</td> </tr> <tr> <td>1</td> <td>ON</td> <td>Send with the most appropriate signal.</td> </tr> </tbody> </table>	Select automatic transmission			0	OFF	Does not send appropriate value automatically.	1	ON	Send with the most appropriate signal.
Select automatic transmission										
0	OFF	Does not send appropriate value automatically.								
1	ON	Send with the most appropriate signal.								















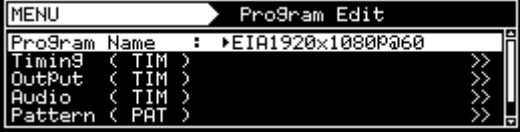













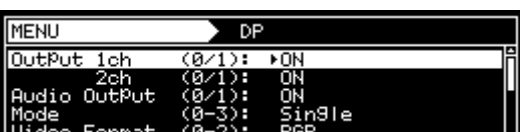

《 Auto Select Item List 》

- When **Auto Select** is ON and program data is saved, the value set by **Auto Select** is reflected.
- The “-” item indicates to use the original setting.

Item	Setting value / Refer source			
AVI InfoFrame				
	AFD pattern (Refer to “6.7 Aspect”) is displayed			Except the left
Active Format Information	Valid			—
Active Format Aspect	Follow the setting of AFD> Type			—
Top Bar	The value calculated from the setting of AFD, Timing			—
Bottom Bar				
Left Bar				
Right Bar				
RGB or YCbCr	Follow the setting of DP> Video Format			
Picture Aspect	Follow the setting of DP> AVI InfoFrame> Video Code (compliant with EIA/CEA-861)			
Repetition	Fixed to '1' in DP			
Audio InfoFrame				
	Follow the setting of Digital Audio> Source			
	Ext.ANALOG L-PCM Int.L-PCM Ext.I2S L-PCM (Option)	to	Ext.ANALOG to DSD Int.DSD)	Except the left
Sampling Frequency	—		44.1kHz	Follow the information of DSD File —
Channel Count	Follow the channel number of 'ON' setting in Digital Audio> Output Channel .			—
	0	1	2 to 8	
	Refer StreamHeader	2ch	2 to 8ch	

b) Set each value of InfoFrame independently

This setting is valid when setting off of a) Send appropriate InfoFrame automatically.

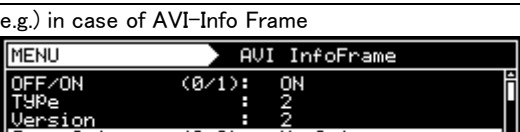
(1)	<p>By using  →  or   , select Program Edit → </p>	 <pre> MENU Program Edit Program Name : ▶EIA1920x1080P@60 Timing (TIM) >>> Output (TIM) >>> Audio (TIM) >>> Pattern (PAT) >>> </pre>
(2)	<p>By using  or   Select Output (TIM) → </p>	 <pre> MENU OutPut All OutPut >>> Analog OutPut >>> Digital OutPut >>> VBI Function >>> </pre>
(3)	<p>By using  or   Select Digital Output → </p>	 <pre> MENU Digital OutPut General >>> DVI >>> iTMD5 / iTMD5-Quad >>> HDMI >>> DP >>> </pre>
(4)	<p>By using  or   Select DP → </p>	 <pre> MENU DP OutPut 1ch (0/1): ▶ON 2ch (0/1): ON Audio OutPut (0/1): ON Mode (0-3): Single Video Format (0-2): RGB </pre>
(5)	<p>Select InfoFrame/Packet to be set. By using  or   Select InfoFrame → </p>	 <pre> MENU InfoFrame AVI InfoFrame >>> Audio InfoFrame >>> </pre>
(6)	<p>《Input Parameter》 By using  or   , →  Or, select by number keys 0/STATUS  to 9/F  → </p>	<p>e.g.) in case of AVI-Info Frame</p>  <pre> MENU AVI InfoFrame OFF/ON (0/1): ON Type : 2 Version : 2 Scan Info (0-2): No Data Bar Info (0-3): Data Not Valid </pre> <p>Refer to 《Setting parameters of InfoFrame /Packet》 about InfoFrame and Packet.</p>

■ AVI InfoFrame

AVI InfoFrame stands for Auxiliary Video Information InfoFrame. It contains information (color space, aspect ratio) of video data.

(1)	OFF/ON	Select to send or not sending of AVI InfoFrame	
		0	OFF Not sending
		1	ON Send
The below items are setting for AVI InfoFrame. It does not affect actual video and audio signal setting.			
(2)	Type	AVI InfoFrame Type	
		2	Display only. This item can not be changed.
(3)	Version	Set version of AVI InfoFrame.	
		1	Version 1
		2	Version 2
(4)	Scan Info	Set Scan Information. This is for setting if Scan process is necessary on video or not.	
		0	No Data No Data
		1	Overscanned Composed for an overscanned display.
		2	Underscanned Composed for an underscanned display.
(5)	Bar Info	Set of Bar Info. This is to set valid/invalid of Bar Information that is described later.	
		0	Data Not Valid Bar Data not valid
		1	Vertical Valid Vert.Bar info valid
		2	Horizontal Valid Horiz.Bar info Valid
		3	Vert. & Horiz. Valid Vert. And Horiz. Bar Info valid
(6)	ActiveF Info	Set Active Format Information Present. This is to set valid/invalid of Active Format Aspect Ratio that is described later.	
		0	No Data No Data
		1	Valid Active Format Information Valid
(7)	RGB or YCbCr	Set RGB or YCbCr(Color Space of video).	
		0	RGB
		1	YCbCr 4:2:2
		2	YCbCr 4:4:4
(8)	ActiveF Aspect	Set Active Format Aspect Ratio (ratio of video part. Except Bar part of Letter Box etc.)	
		0	Same Picture
		1	4:3(center)
		2	16:9(center)
		3	14:9(center)
		4	Box 16:9(top)
		5	Box 14:9(top)
		6	Box > 16:9(center)
		7	4:3(14:9 center)
		8	16:9(14:9 center)
		9	16:9(4:3 center)

(9)	Picture Aspect	Set Picture Aspect Ratio (ratio of video part. Include Bar part of Letter Box etc.)	
		0	No Data No Data
		1	4:3 4:3
		2	16:9 16:9
(10)	Scaling	Set Non-Uniform Picture Scaling (scaled direction of video).	
		0	No Known No Known non-uniform Scaling
		1	Horizontal Picture has been scaled horizontally
		2	Vertical Picture has been scaled vertically
		3	Horiz. & Vert. Picture has been scaled horizontally and vertically
(11)	Colorimetry	Set Colorimetry (which coefficient of standard is used when converting to color difference data.)	
		0	No Data No Data
		1	SMPTE170M ITU601 SMPTE170M/ITU601
		2	ITU709 ITU709
		3	Extended Valid Extended Colorimetry Information Valid
(12)	Video Code	Set Video Format Identification Code.	
		0 - 64	Refer to CEA-861-E about the timing that each Code indicates.
(13)	Repetition	1	Set Pixel Repetition Factor. Note) this item can not be set in DP.
(14)	Top Bar	0 - 65535	Set Line Number of "End of Top Bar". (The size of the top Bar of Letter BOX.)
(15)	Bottom Bar	0 - 65535	Set Line Number of "Start of Bottom Bar". (The size of the bottom Bar of Letter BOX.)
(16)	Left Bar	0 - 65535	Set Pixel Number of "End of Left Bar". (The size of the left Bar of Pillar BOX.)
(17)	Right Bar	0 - 65535	Set Pixel Number of "Start of Right Bar". (The size of the right Bar of Pillar BOX.)
(18)	RGB Quan.Range	Set RGB Quantization Range (the Quantization Range in case the Colorimetry is RGB video.)	
		0	Default
		1	Limited Range
		2	Full Range
(19)	YCC Quan.Range	Set YCC Quantization Range (the Quantization Range in case the Colorimetry is Color Difference video.)	
		0	Limited Range
		1	Full Range
(20)	Extended Colo.	Set Extended Colorimetry. (This item is referred when "Extended Valid" is set in "Colorimetry".)	
		0	XvYCC601
		1	XvYCC709
		2	sYCC601
		3	AdobeYCC601
		4	AdobeRGB

(21)	IT content	Set IT Content. (Set if video is IT content or not.)			
		0	No Data		
		1	IT content		
(22)	IT Content Type	Set the type of IT Content.			
		0	Graphics		
		1	Photo		
		2	Cinema		
		3	Game		
(23)	Checksum	Set Check sum.			
		0	Auto	The value is calculated automatically.	
		1	Manual	Set the designated value.	
			00h - FFh		
(24)	Length		0 - 15 [byte]	Set the length of AVI InfoFrame. (except Packet Header and Checksum) The default value is 13 bytes.	*1
(25)	Data Byte 14, 15		00h - 0FFh	Set the value of Data Byte14 and 15.	

Note)

*1 Setting of Checksum, Length, Data Byte 14,15 are options. It needs license input. Please contact ASTRODESIGN for details.

If the unit does not have license, it is fixed as: Checksum=Auto, Length=13bytes.

■ Audio InfoFrame

Audio InfoFrame is sent containing audio information.

(1)	OFF/ON	Select to send or not sending of Audio InfoFrame.	
		0	OFF Not sending
		1	ON Send
The below items are setting for Audio InfoFrame. <u>It does not affect actual video and audio signal setting.</u>			
(2)	Type	Audio InfoFrame Type	
		4	Display only. This item can not be changed.
(3)	Version	Audio InfoFrame Version	
		1	Display only. This item can not be changed.
(4)	Coding Type	Set Audio Coding Type.	
		0	Refer StreamHeader Refer to Stream Header
		1	IEC60958 PCM
		2	AC-3
		3	MPEG1(Layers 1&2)
		4	MP3(MPEG1 Layer 3)
		5	MPEG2(multi ch.)
		6	AAC
		7	DTS
		8	ATRAC
		9	One Bit Audio
		A	Dolby Digital +
		B	DTS-HD
		C	MLP
		D	DST
E	WMA Pro		
F	Refer Extension		
(5)	Coding Ext Type	Set Audio Coding Ext Type.	
		0	HE-AAC
		1	HE-AACv2
		2	MPEG Surround
(6)	Channel Count	Set Audio Channel Count.	
		0	Refer StreamHeader Refer to Stream Header
		1	2ch
		↓	↓
		7	8ch
(7)	Sampling Freq	Set Sampling Frequency.	
		0	Refer StreamHeader Refer to Stream Header
		1	32kHz
		2	44.1kHz
		3	48kHz
		4	88.2kHz
		5	96kHz
		6	176.4kHz
		7	192kHz

(8)	Sample Size	Set Sample Size.									
		0	Refer StreamHeader	Refer to Stream Header							
		1	16bit								
		2	20bit								
		3	24bit								
(9)	Speaker Placement	Set Channel / Speaker Allocation.									
			8ch	7ch	6ch	5ch	4ch	3ch	2ch	1ch	
		0		-	-	-	-	-	FR	FL	
		1		-	-	-	-	LFE	FR	FL	
		2		-	-	-	FC	-	FR	FL	
		3		-	-	-	FC	LFE	FR	FL	
		4		-	-	RC	-	-	FR	FL	
		5		-	-	RC	-	LFE	FR	FL	
		6		-	-	RC	FC	-	FR	FL	
		7		-	-	RC	FC	LFE	FR	FL	
		8		-	RR	RL	-	-	FR	FL	
		9		-	RR	RL	-	LFE	FR	FL	
		10		-	RR	RL	FC	-	FR	FL	
		11		-	RR	RL	FC	LFE	FR	FL	
		12			RC	RR	RL	-	FR	FL	
		13			RC	RR	RL	-	LFE	FR	FL
		14			RC	RR	RL	FC	-	FR	FL
		15			RC	RR	RL	FC	LFE	FR	FL
		16	RRC	RLC	RR	RL	-	-	FR	FL	
		17	RRC	RLC	RR	RL	-	LFE	FR	FL	
		18	RRC	RLC	RR	RL	FC	-	FR	FL	
		19	RRC	RLC	RR	RL	FC	LFE	FR	FL	
		20	FRC	FLC	-	-	-	-	FR	FL	
		21	FRC	FLC	-	-	-	LFE	FR	FL	
		22	FRC	FLC	-	-	FC	-	FR	FL	
		23	FRC	FLC	-	-	FC	LFE	FR	FL	
		24	FRC	FLC	-	RC	-	-	FR	FL	
		25	FRC	FLC	-	RC	-	LFE	FR	FL	
		26	FRC	FLC	-	RC	FC	-	FR	FL	
		27	FRC	FLC	-	RC	FC	LFE	FR	FL	
		28	FRC	FLC	RR	RL	-	-	FR	FL	
		29	FRC	FLC	RR	RL	-	LFE	FR	FL	
		30	FRC	FLC	RR	RL	FC	-	FR	FL	
31	FRC	FLC	RR	RL	FC	LFE	FR	FL			
(10)	Level Shift Value	Set Level Shift Value.									
		0 -15	Set DB value.								
(11)	Down-mix	Set Down –mix Inhibit Flag.									
		0	Permitted / No Info			Permitted or no information about any assertion of this					
		1	Prohibited			Prohibited					

(12)	LFE PB Level	Set LFE Playback Level.	
		0	Unknown
		1	0dB Playback
		2	+10dB Playback

4.12.10 Setting for eDP (for VM-1826)

<eDP Power Sequence Specification>

VM-1826 can set the below type of Power Sequence.

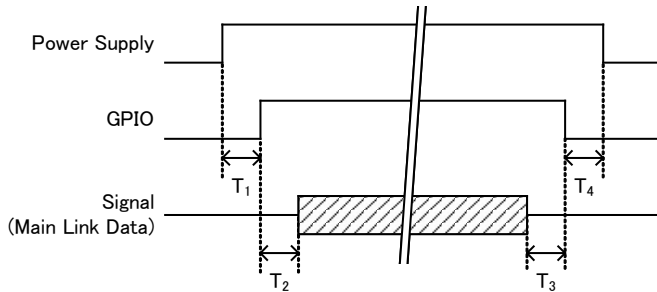

- T₁ : Power Supply ON => GPIO ON
- T₂ : GPIO ON => Signal ON
- T₃ : Signal OFF => GPIO OFF
- T₄ : GPIO OFF => Power Supply OFF















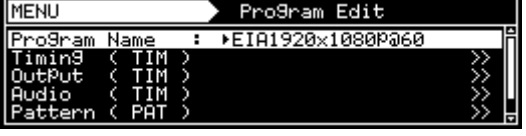



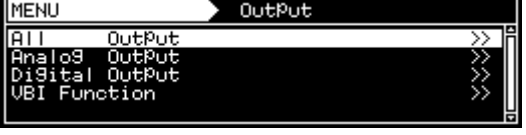











a) Configuration setting

(1)	<p>By using → or .</p> <p>Select Configuration → .</p>							
(2)	<p>《Select eDP Mode》</p> <p>By using or → .</p>	<p>Set DP/eDP Unit(VM-1826) eDP Mode.</p> <table border="1" data-bbox="798 1344 1356 1426"> <tr> <td>0</td> <td>Disable</td> <td>eDP Mode is set to be Disable.</td> </tr> <tr> <td>1</td> <td>Enable</td> <td>eDP Mode is set to be Enable.</td> </tr> </table>	0	Disable	eDP Mode is set to be Disable.	1	Enable	eDP Mode is set to be Enable.
0	Disable	eDP Mode is set to be Disable.						
1	Enable	eDP Mode is set to be Enable.						

Note 1) if eDP Mode is Disable, the setting of Power control and GPIO can not be set in VM-1826 DP, eDP unit.

Note 2) While eDP Mode is Enable, and press "SIG ON" key, Power Sequence is executed by the setting value of power control and GPIO. (If voltage value of power output is less than 1V, it is detected as error, and power sequence is not executed.)

b) Setting of Power Sequence

















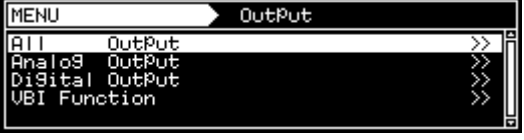







(1)	<p>By using  →  or  ,</p> <p>Select Program Edit → </p>	
(2)	<p>By using  or  ,</p> <p>Select Output (TIM) → </p>	
(3)	<p>By using  or  ,</p> <p>Select Digital Output → </p>	
(4)	<p>Select  or  ,</p> <p>Select eDP → </p>	
(5)	<p>By using  or  ,</p> <p>Select Power Supply Control → </p>	<p>Refer to «Parameter for power control» in the following page about parameter details.</p>
	<p>«Input parameter»</p> <p>By using  or  , → </p> <p>Or select by number keys</p> <p> to  → </p>	

Note) power output and control is done in one line.

《Setting item for power control》

(1)	Power Supply Control (0-2)	Select the control method of output power.		
		0	Off	Do not control power
		1	Manual	Control power manually.
		2	RS-232C	Control external power input through RS-232C.
(2)	Power Supply Select (0-4)	Select power to output.		
		0	None	No power output.
		1	5V	5V(internal power) is output.
		2	3.3V	3.3V(ternal power) is output.
		3	Ext1	External input power 1 is output.
4	Ext2	External input power 2 is output.		
(3)	Time	on PW => GPIO	Set the time (T1) from Output ON until GPIO ON.	(20-2000 ms)
		on GPIO => SIG	Set the time (T2) from GPIO ON until Video Output ON.	(20-2000 ms)
		off SIG => GPIO	Set the time (T3) from Video Output ON until Video Output OFF.	(20-2000 ms)
		off GPIO => PW	Set the time (T3) from GPIO OFF until Power Output OFF.	(20-2000 ms)

c) Setting for GPIO

①	By using  or  , select Program Edit → 	
②	By using  or  , Select Output (TIM) → 	
③	By using  or  , Select Digital Output → 	
④	By using  or  , Select eDP → 	
⑤	By using  or  , Select GPIO → 	Refer to «Parameter for GPIO setting» in next.
	«Input parameter» By using  or  , select it →  Or Select by  to  (number keys) → 	

Note) power output and power control is executed by maximum 2 lines.

«Parameter for GPIO setting»

(1)	Level	Set level in GPIO0 to 7.		
		0	L	Set Level as Low.
		1	H	Set Level as High.
(2)	PullUp	Set PullUP in GPIO0 to 7.		
		0	OFF	Set PullUp OFF.
		1	ON	Set PullUp ON.

4.13 V-by-One HS (VM-1825)

4.13.1 Connectors and pin assignments

- Connector: MDR 10226-1210-PE (made by 3M)

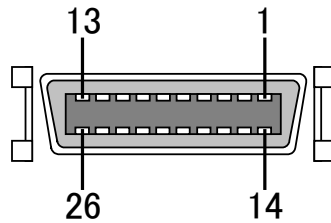





























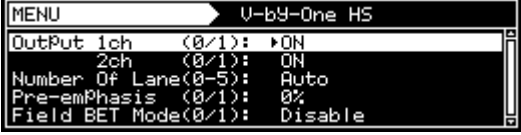



1CH		2CH	
Pin No.	Symbol	Pin No.	Symbol
1	GND	1	GND
2	GND	2	GND
3	NC	3	NC
4	Tx0n	4	Tx4n
5	Tx0p	5	Tx4p
6	Tx1n	6	Tx5n
7	Tx1p	7	Tx5p
8	GND	8	GND
9	SCL	9	SCL
10	GND	10	GND
11	NC	11	NC
12	Tx3n	12	Tx7n
13	Tx3p	13	Tx7p
14	HTPDN1	14	HTPDN2
15	LOCKN1	15	LOCKN2
16	GND	16	GND
17	GND	17	GND
18	SDA	18	SDA
19	GND	19	GND
20	NC	20	NC
21	NC	21	NC
22	Tx2n	22	Tx6n
23	Tx2p	23	Tx6p
24	NC	24	NC
25	GND	25	GND
26	GND	26	GND

*1 No power is supplied.

4.13.2 V-by-One HS setting procedure

<V-by-One HS setting procedure>

<p>(1) Select Program Edit using  →  or  INC  DEC, and then press .</p>	 <pre> MENU Program Edit Program Name : 170MHz 10Bit Timing < TIM > >> Output < TIM > >> Audio < TIM > >> Pattern < PAT > >> </pre>
<p>(2) Select Output using  or  INC  DEC, and then press .</p>	 <pre> MENU OutPut All OutPut >> Analog OutPut >> Digital OutPut >> VBI Function >> </pre>
<p>(3) Select Digital Output using  or  INC  DEC, and then press .</p>	 <pre> MENU Digital OutPut DVI >> iTMD5 >> HDMI >> DP >> U-by-One HS >> </pre>
<p>(4) Select V-by-One HS using  or  INC  DEC, and then press .</p>	 <pre> MENU U-by-One HS Output 1ch (0/1): ON 2ch (0/1): ON Number Of Lane(0-5): Auto Pre-emphasis (0/1): 0% Field BET Mode(0/1): Disable </pre>
<p>(5) Select the items using  or  INC  DEC, and then press .</p> <p><Inputting the parameters></p> <p>Select the parameters using  or  INC  DEC, and then press .</p> <p>Alternatively: Select the parameters using the number keys ( to ), and then press .</p>	<p>For further details on the parameters, refer to the table below.</p>

<V-by-One HS setting parameters>

(1)	Output 1ch (0/1) Output 2ch (0/1)	This sets On or Off for each channel.			
		0	Off No output.		
		1	On Output.		
(2)	Number Of Lane (0/5)	This sets the number of data lanes to be output from V-by-One HS.			
		0	Auto The number of data lanes is changed automatically in line with the dot clock frequency. * Only lanes 1 to 4 are supported.		
				20M - 75 MHz	1 Lane
				75M - 150 MHz	2 Lane
				150M - 300 MHz	4 Lane
		1	1 Lane The image is output using one lane as the number of data lanes. The same image is output from output channels 1 and 2.		
		2	2 Lane The image is output using two lanes as the number of data lanes. The same image is output from output channels 1 and 2.		
		3	4 Lane The image is output using four lanes as the number of data lanes. The same image is output from output channels 1 and 2.		
		4	8 Lane The image is output using eight lanes as the number of data lanes.		
		5	16 Lane The image is output using 16 lanes as the number of data lanes.		
(3)	Split(0/9)	This selects the screen splitting type in the x4 mode or 4Kx2K mode which uses the frame memory on the board.			
		8 Lane			
		0	MODE0 Split-into-4 output in the form of a square divided into 4 equal parts		
		1	MODE1 Vertically split-into-4 output		
		2	MODE2 Horizontally split-into-2 output		
		3	MODE3 Vertically split-into-2 output		
		4	MODE4 No split		
		5	MODE0(x4 mode) Non Dividing Mode		
		6	MODE1(x4 mode) Normal Mode		
		7	MODE2(x4 mode) Cross Mode		
		8	MODE3(x4 mode) Dividing Normal Mode		
		9	MODE4(x4 mode) Dividing Cross Mode		
		0	MODE0 Cross split to 4 + vertically split to 2		
		1	MODE1 Vertically split to 4 + vertically split to 2		
		2	MODE2 Horizontally split to 2 + vertically split to 2		
		3	MODE3 Vertically split to 2 + vertically split to 2		
		4	MODE4 Vertically split to 2 + No split (1) (Non dividing Mode)		
		5	MODE5 Vertically split to 2 + No split (2) (Normal Mode)		
		6	MODE6 Vertically split to 2 + No split (3) (Cross Mode)		
		7	MODE7 Vertically split to 2 + split (1) (Dividing Normal Mode)		
		8	MODE8 Vertically split to 2 + split (2) (Dividing Cross Mode)		
		9	MODE9 No split		
(4)	Pre-Emphasis(0/1)	This sets the pre-emphasis.			
		0	0% The pre-emphasis is set to 0%.		
		1	100% The pre-emphasis is set to 100%.		

(5)	3D Flag (0/1)	This sets 3D flag. It is compliant with "3D flag on DE active period" of the V-by-One HS Standard Ver. 1.3. Our product does not support "3D flag on blanking period."	
		0	Disable 3D Flag is set as Disable.
		1	Enable 3D Flag is set as Enable.
(6)	Field BET Mode(0/1)	This sets the Field BET Mode.	
		0	Disable The Field BET Mode is set to Disable.
		1	Enable The Field BET Mode is set to Enable.

4.13.3 Data transfer systems

<Specifications of mode during 4K×2K mode output>

During the 4K×2K mode output, 8 lanes are combined to output one screen.

[4K×2K 60 Hz 8-lane output]

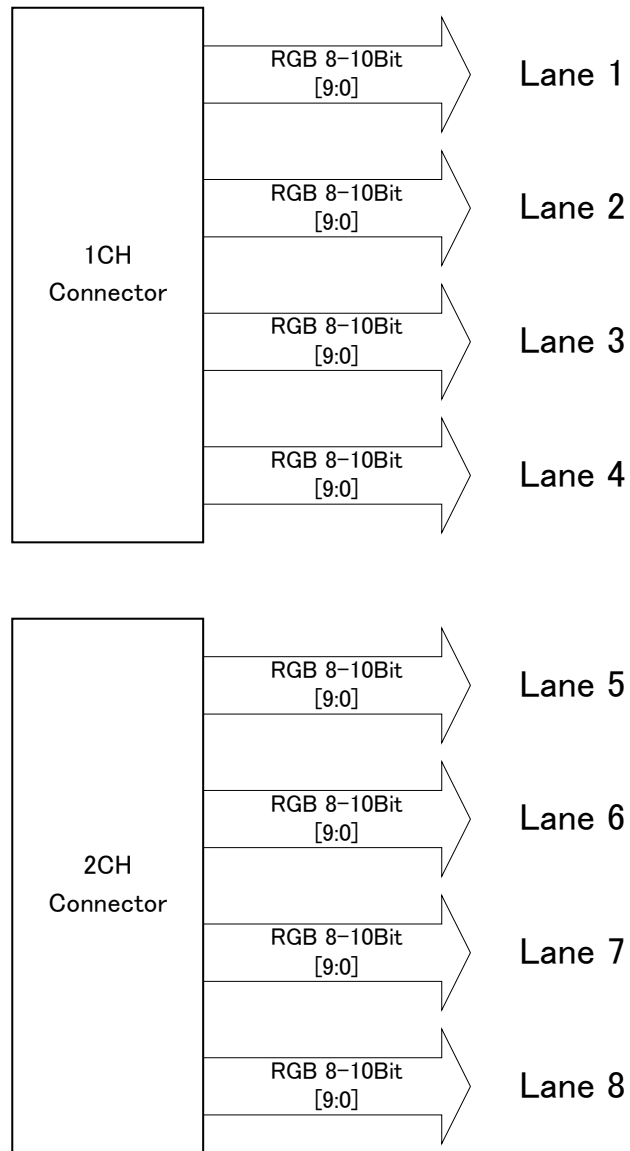

[1] MODE0 (8 Lane) - Normal

The image is split into 4 in the form of a square divided into 4 equal parts and assigned in sequence using lanes 1 and 2 for the top left part, lanes 3 and 4 for the top right part, lanes 5 and 6 for the bottom left part and lanes 7 and 8 for the bottom right part.

Given here as an example where the resolution is 4096×2048 , the dot clock frequency is 592 MHz and the output bit depth is 10 bits.

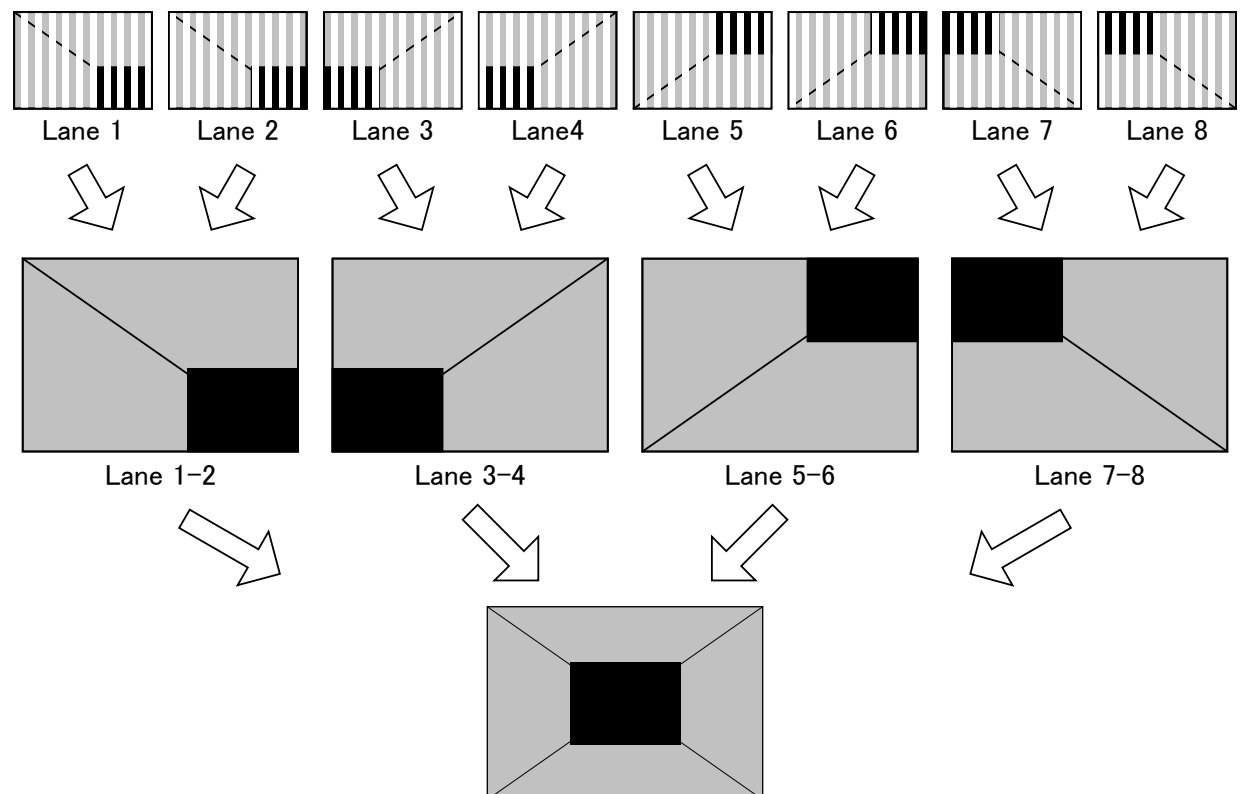
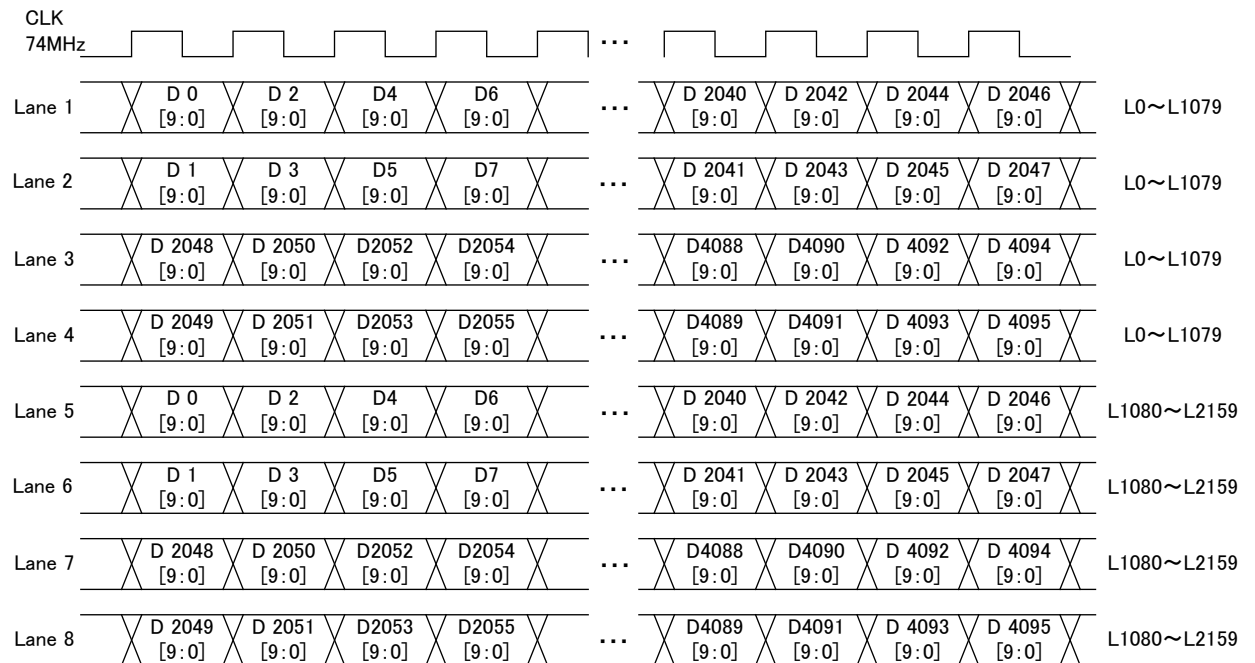

[2] MODE1 (8 Lane) - 4Split

The image is split horizontally into four parts and assigned in sequence from the left using lanes 1 and 2, lanes 3 and 4, lanes 5 and 6 and lanes 7 and 8.

Given here as an example where the resolution is 4096 × 2048, the dot clock frequency is 592 MHz and the output bit depth is 10 bits.

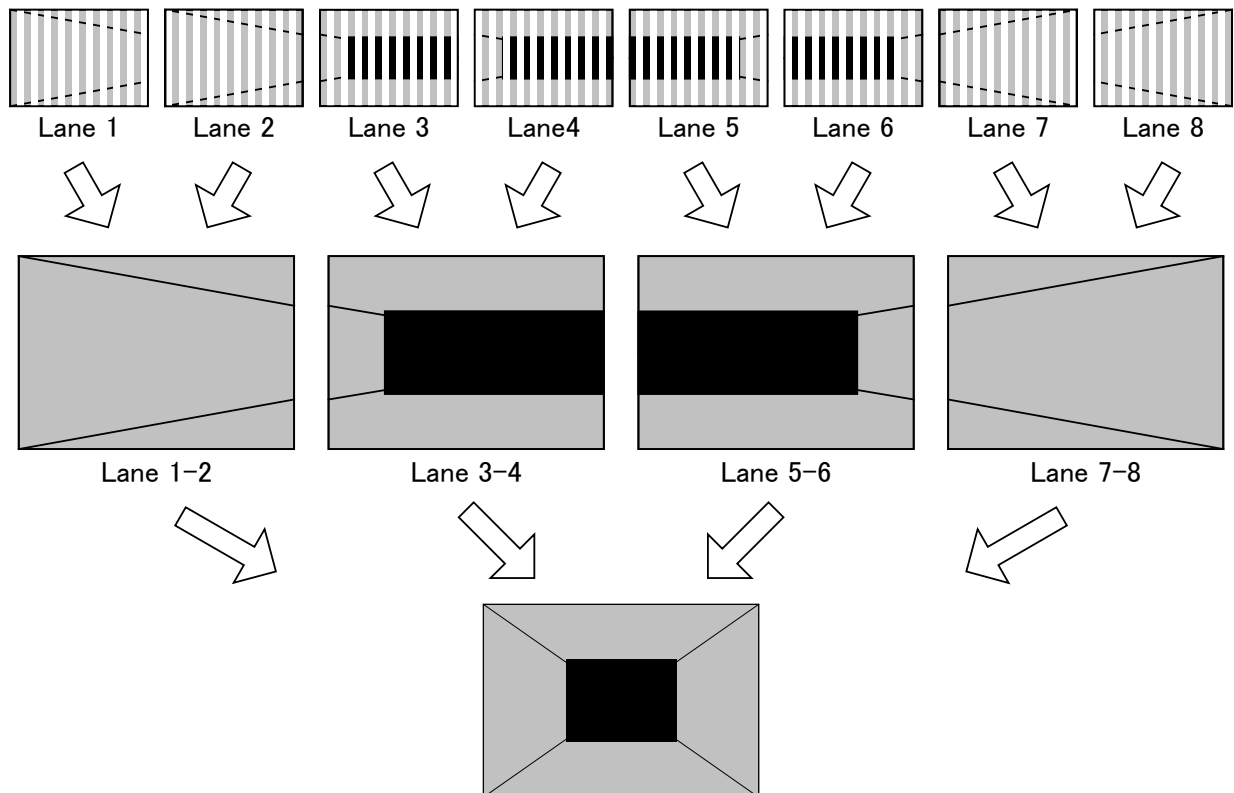
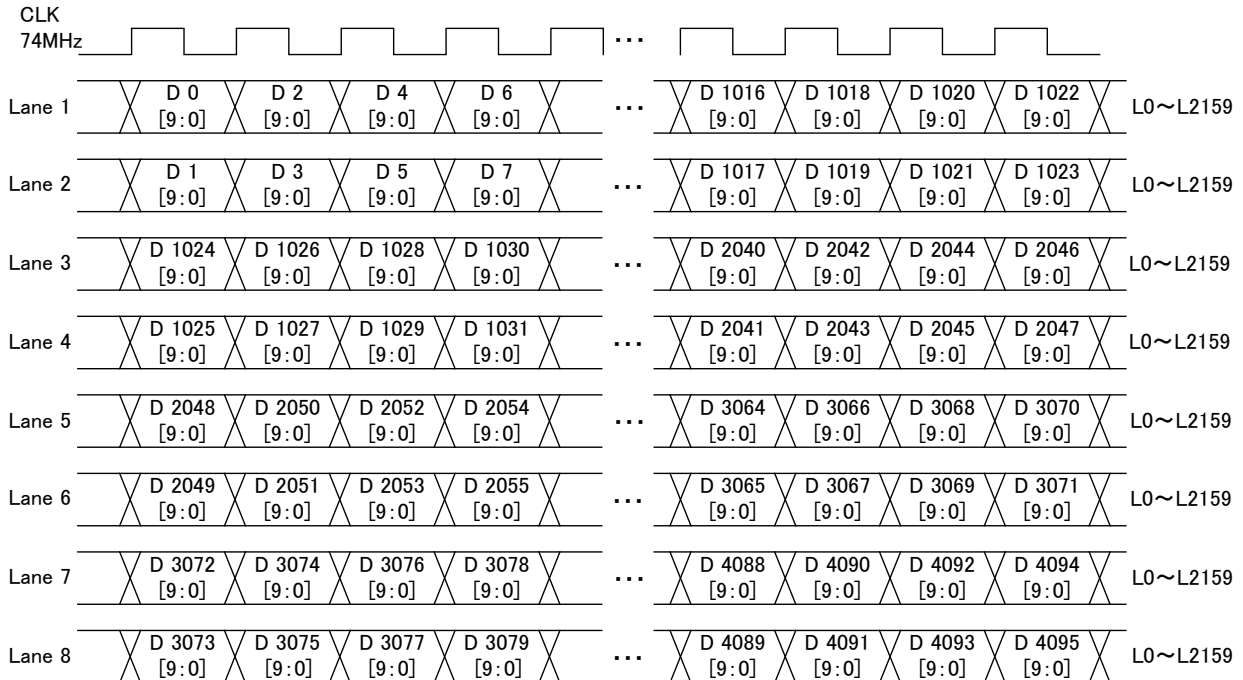

[3] MODE2 (8 Lane) (screen split horizontally into 2)

Using lanes 1 and 2 and lanes 3 and 4, the top half of the image is output in the even and odd numbers; similarly, using lanes 5 and 6 and lanes 7 and 8, the bottom half of the image is output in the even and odd numbers.

Given here as an example where the resolution is 4096 × 2048, the dot clock frequency is 592 MHz and the output bit depth is 10 bits.

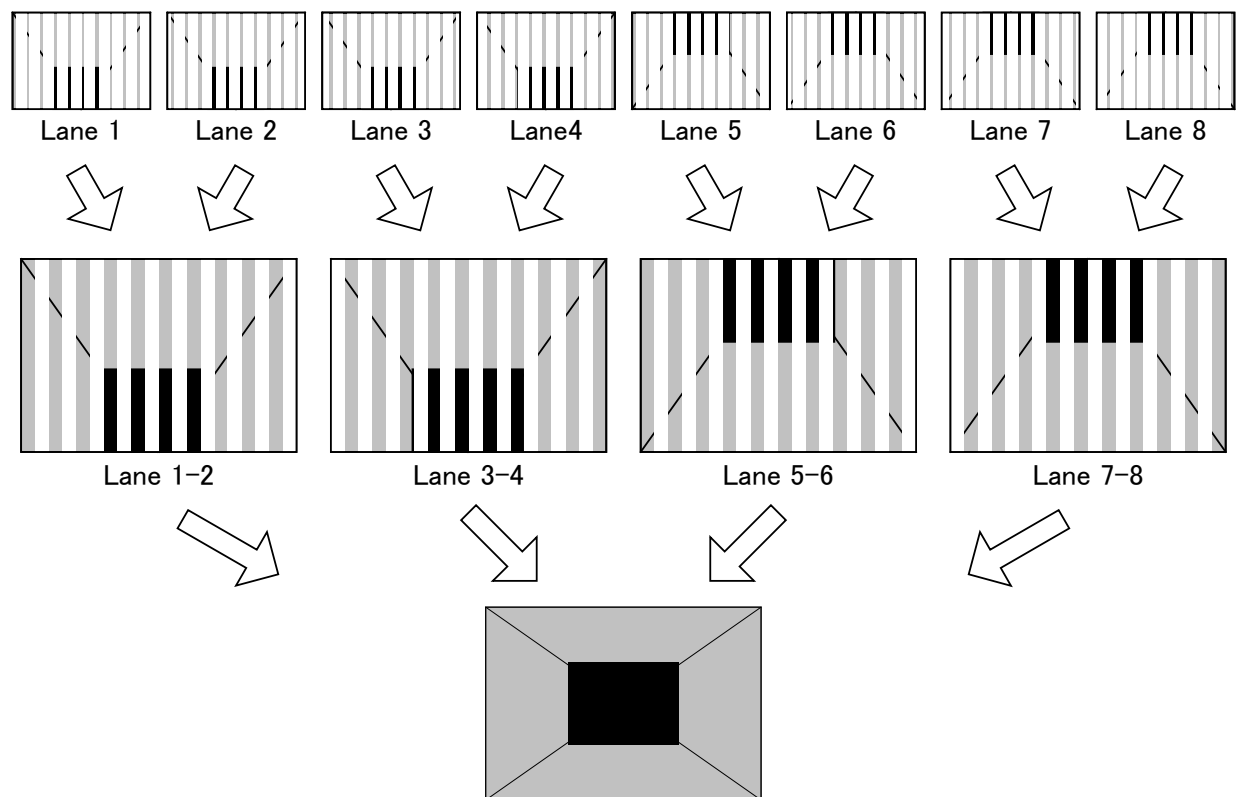
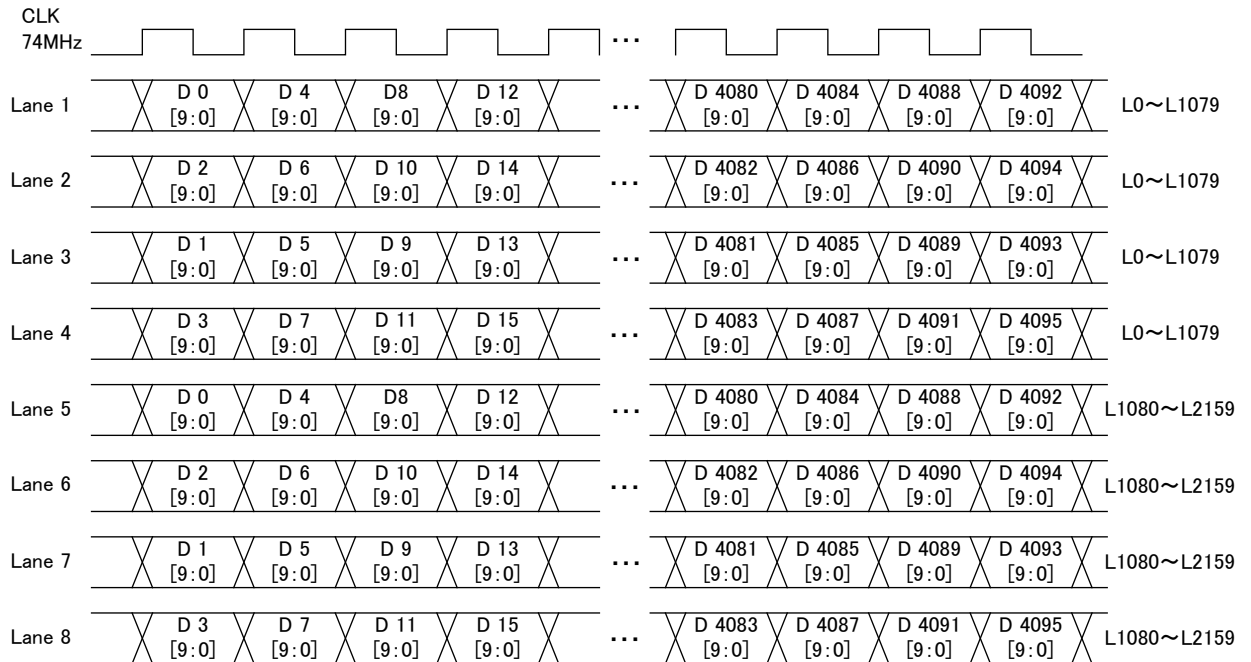

[4] MODE3 (8 Lane) - (screen split vertically into 2)

Using lanes 1 and 2 and lanes 3 and 4, the left half of the image is output in the even and odd numbers; similarly, using lanes 5 and 6 and lanes 7 and 8, the right half of the image is output in the even and odd numbers.

Given here as an example where the resolution is 4096 × 2048, the dot clock frequency is 592 MHz and the output bit depth is 10 bits.

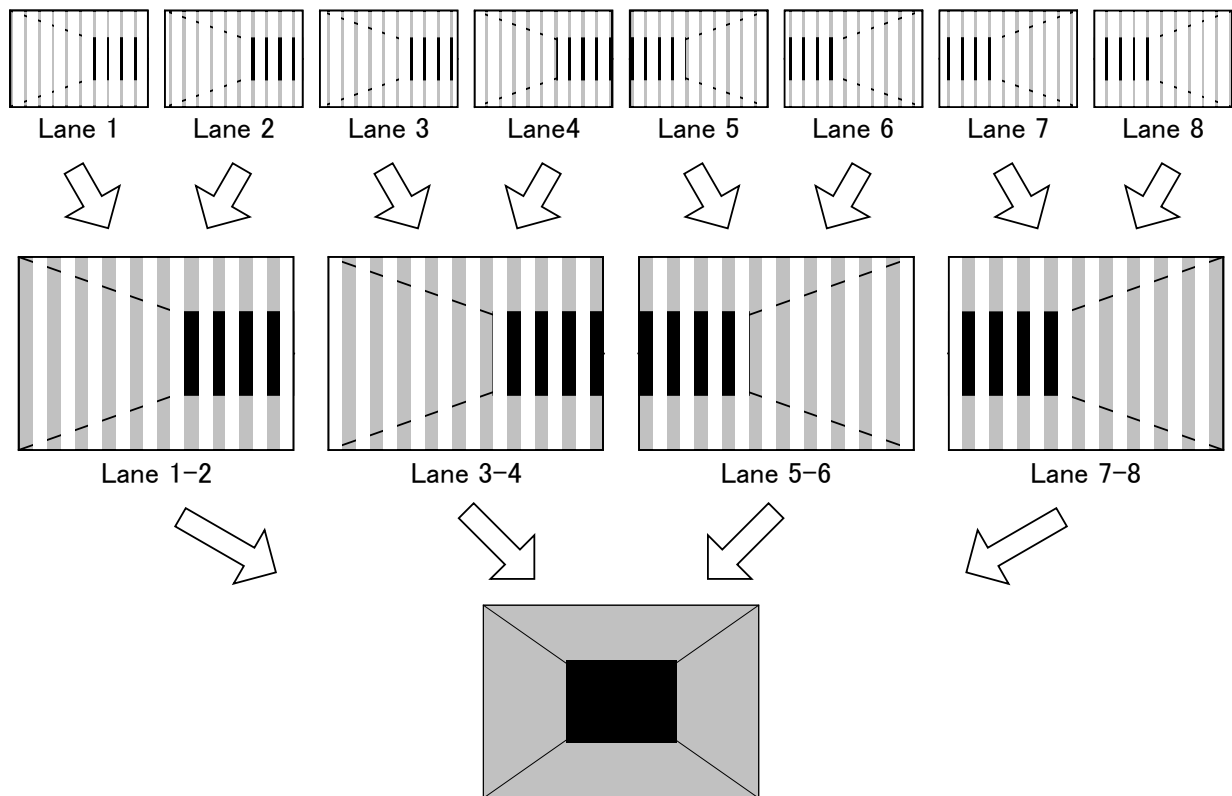
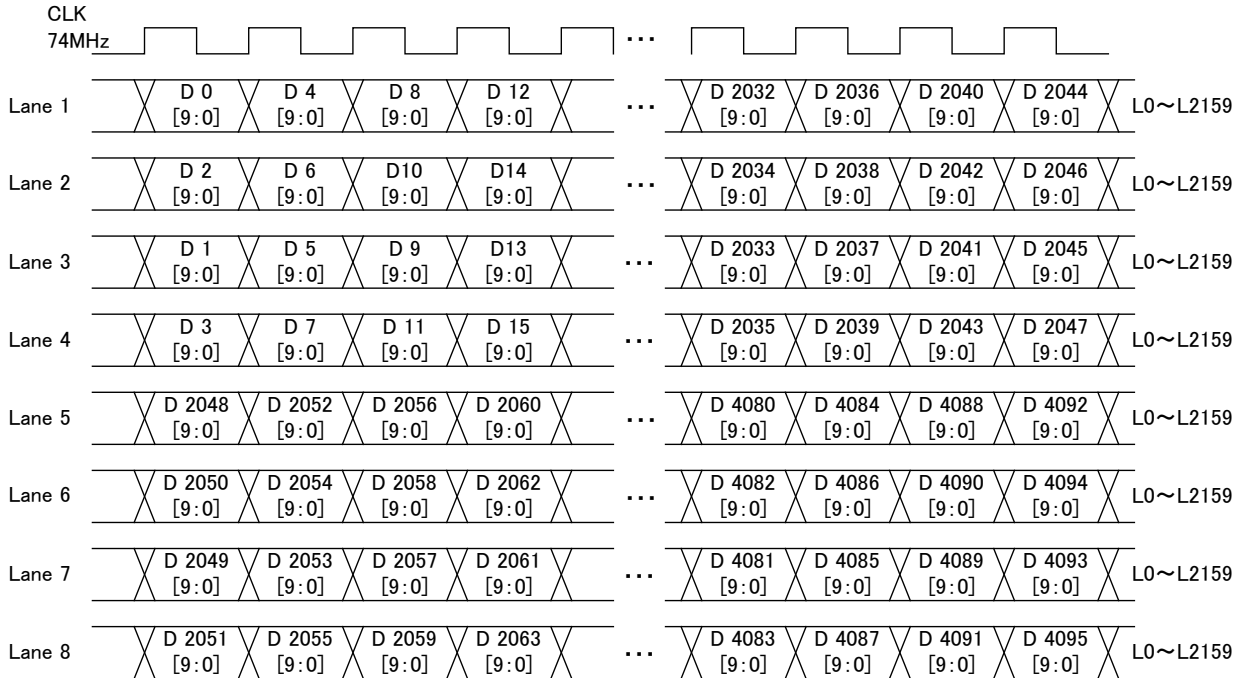

[5] MODE4 (8 Lane) – No Split

Using lanes 1 to 4, the EVEN pixels are output, and using lanes 5 to 8, the ODD pixels are output.

Given here as an example where the resolution is 4096 x 2048, the dot clock frequency is 592 MHz and the output bit depth is 10 bits.

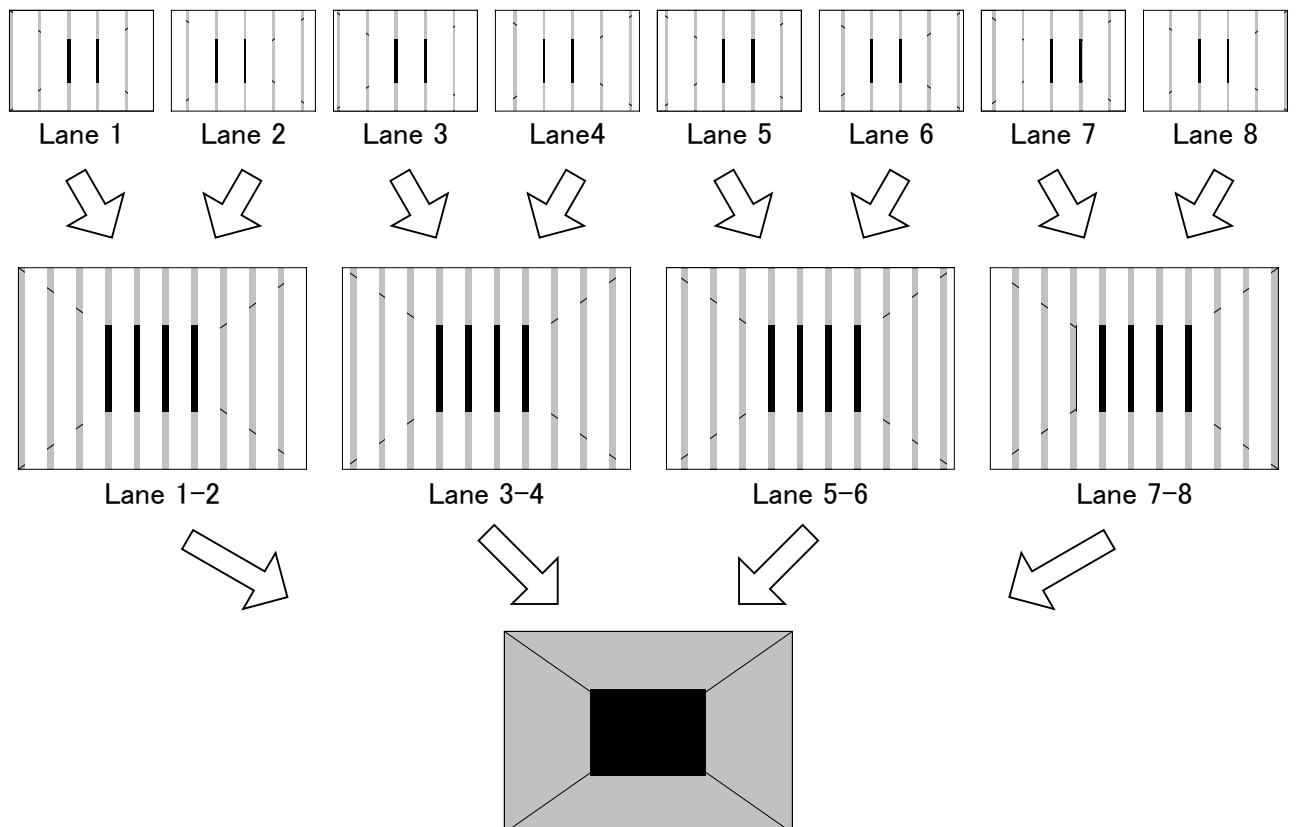
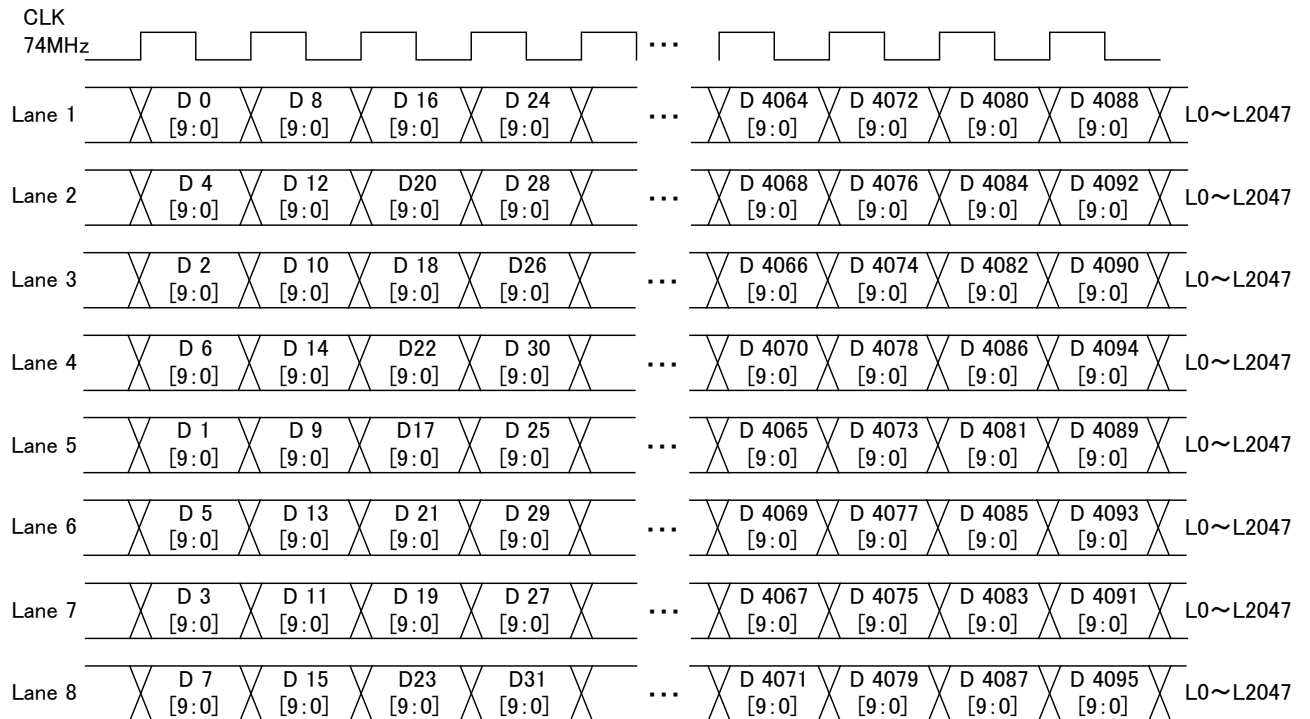

<Specifications of x4 mode output>

For the Full HD 240 Hz output, 8 lanes are combined to output one screen.

[Full HD 240 Hz 8-lane output]

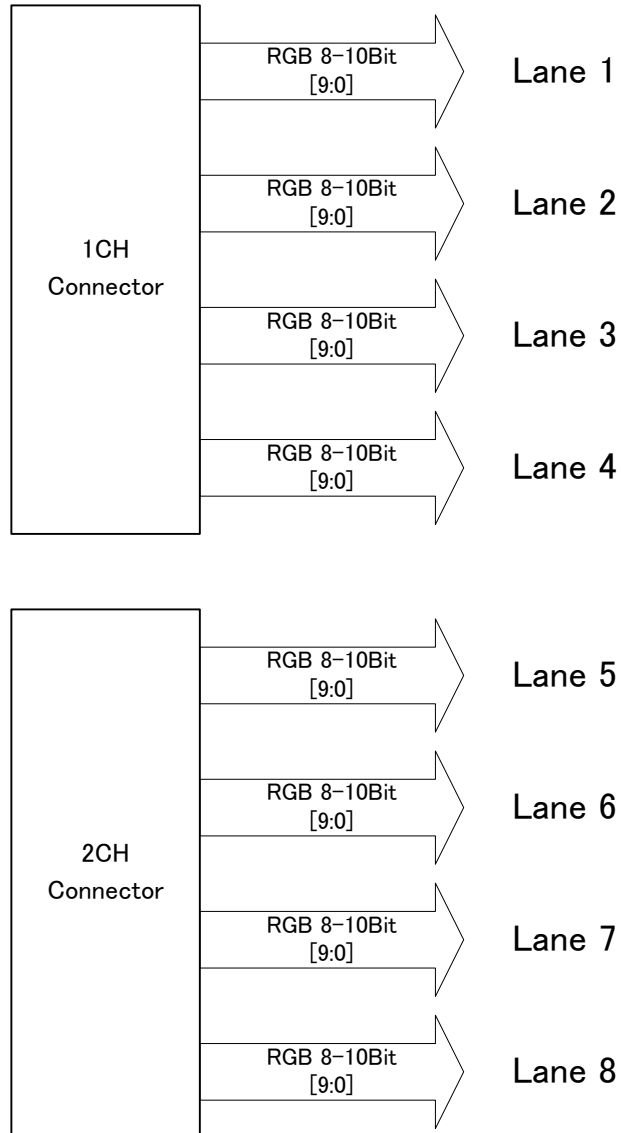

[1] MODE0 (8 Lane) - No screen splitting

Using 1-8 lanes, the image is output with the pixel assignment as below without splitting.

This example is a case where the resolution is 1920 × 1080, the dot clock frequency is 592 MHz and the output bit depth is 10 bits.

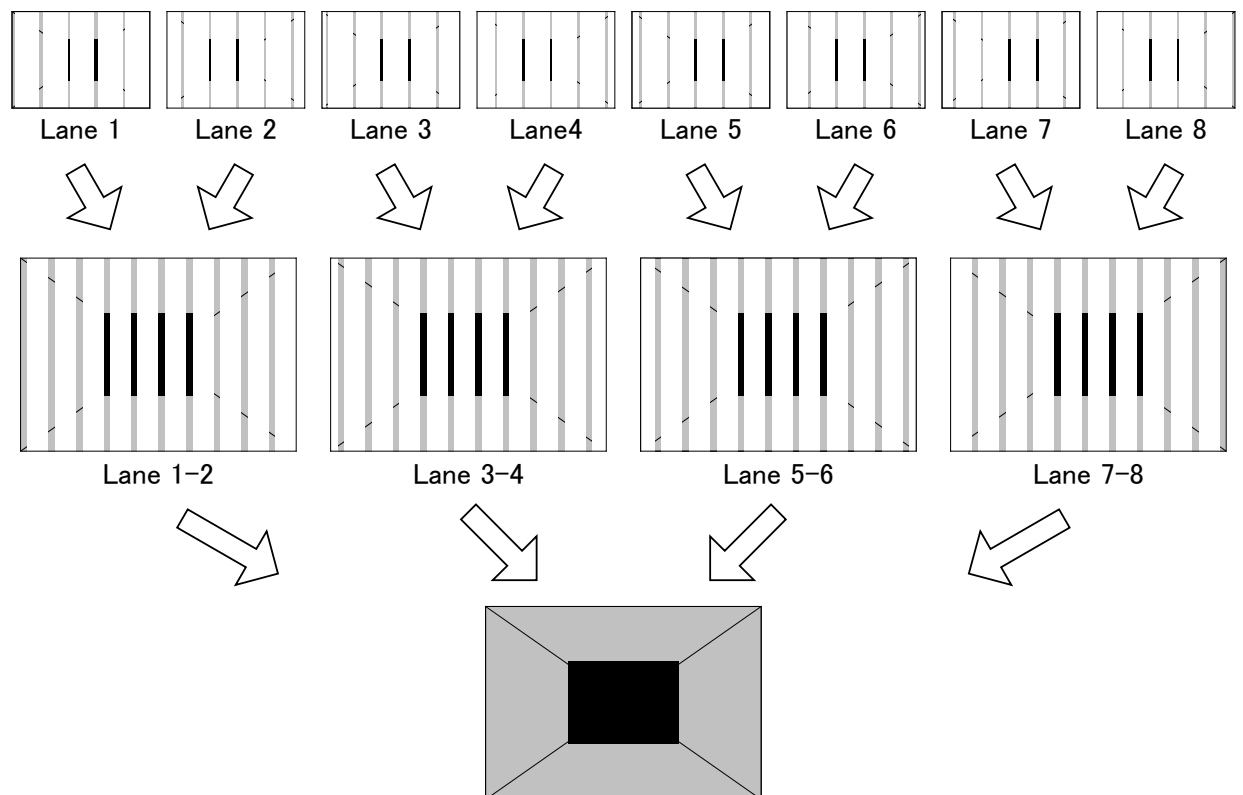
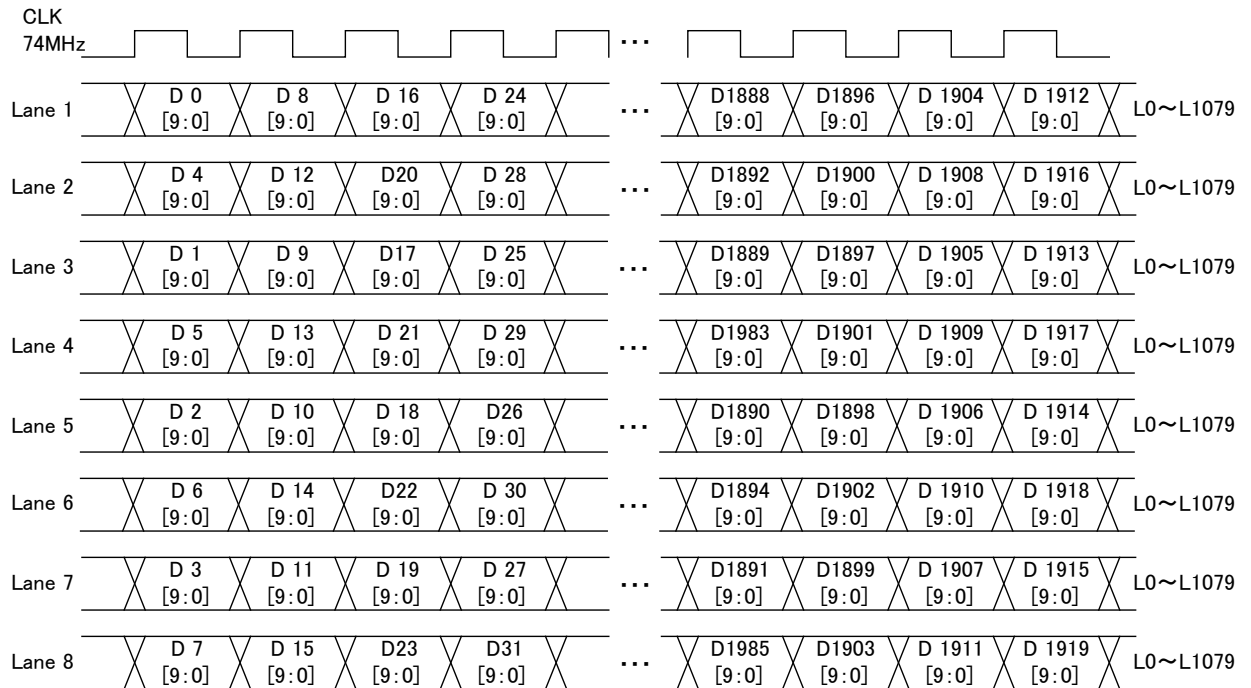

[2] MODE1 (8 Lane) - Normal Mode

Using 1-8 lanes, the image is output with the pixel assignment as below without splitting the screen.

This example is a case where the resolution is 1920 x 1080, the dot clock frequency is 592 MHz and the output bit depth is 10 bits.

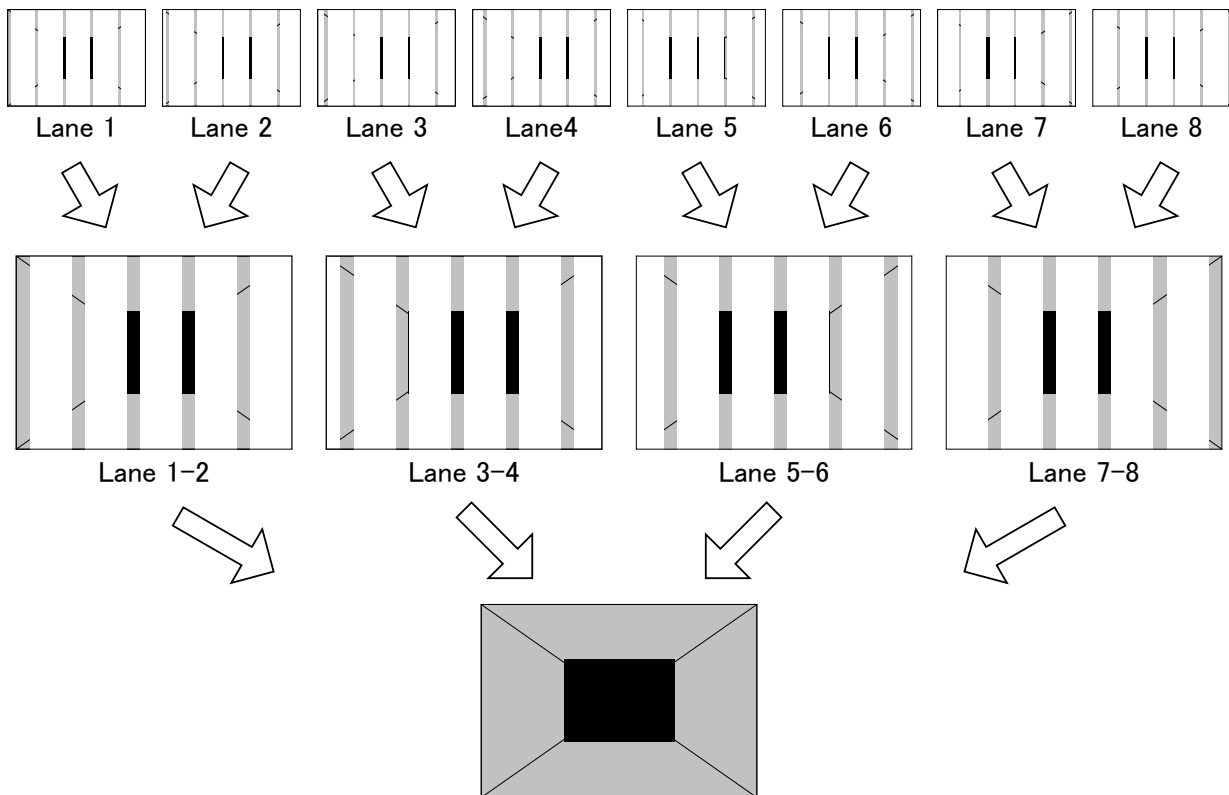
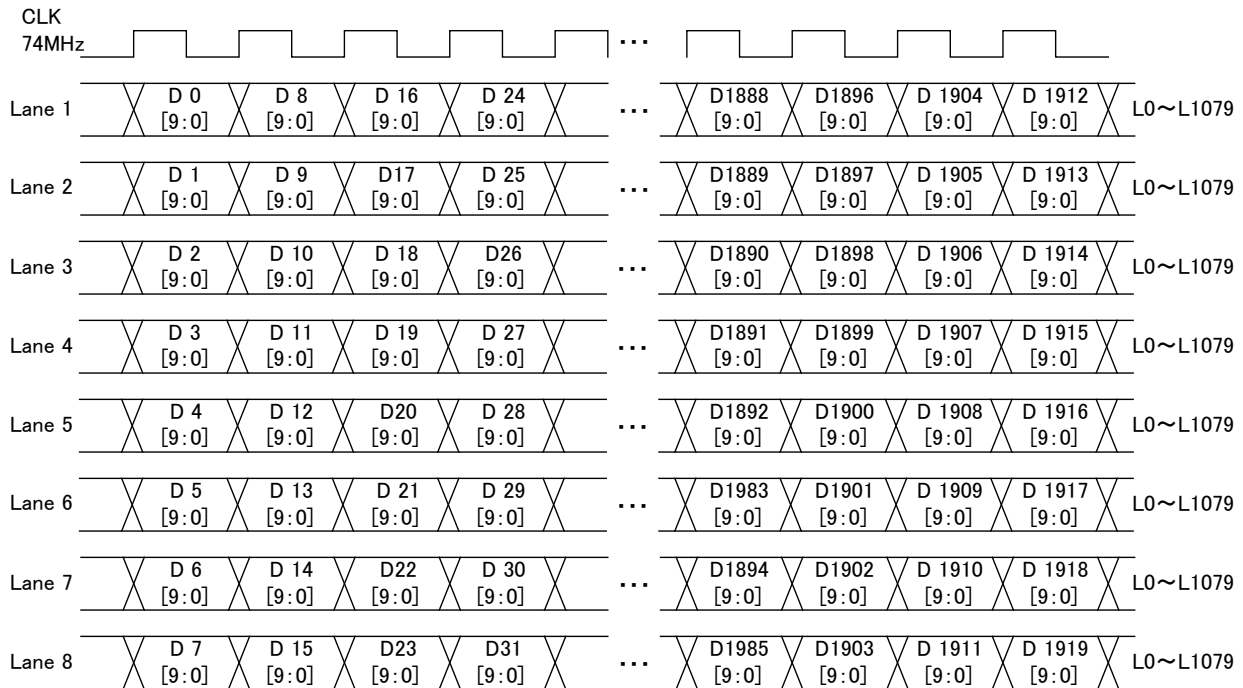

[3] MODE2 (8 Lane) - Cross Mode

Using 1-8 lanes, the image is output with the pixel assignment as below without splitting the screen.

This example is a case where the resolution is 1920 × 1080, the dot clock frequency is 592 MHz and the output bit depth is 10 bits.

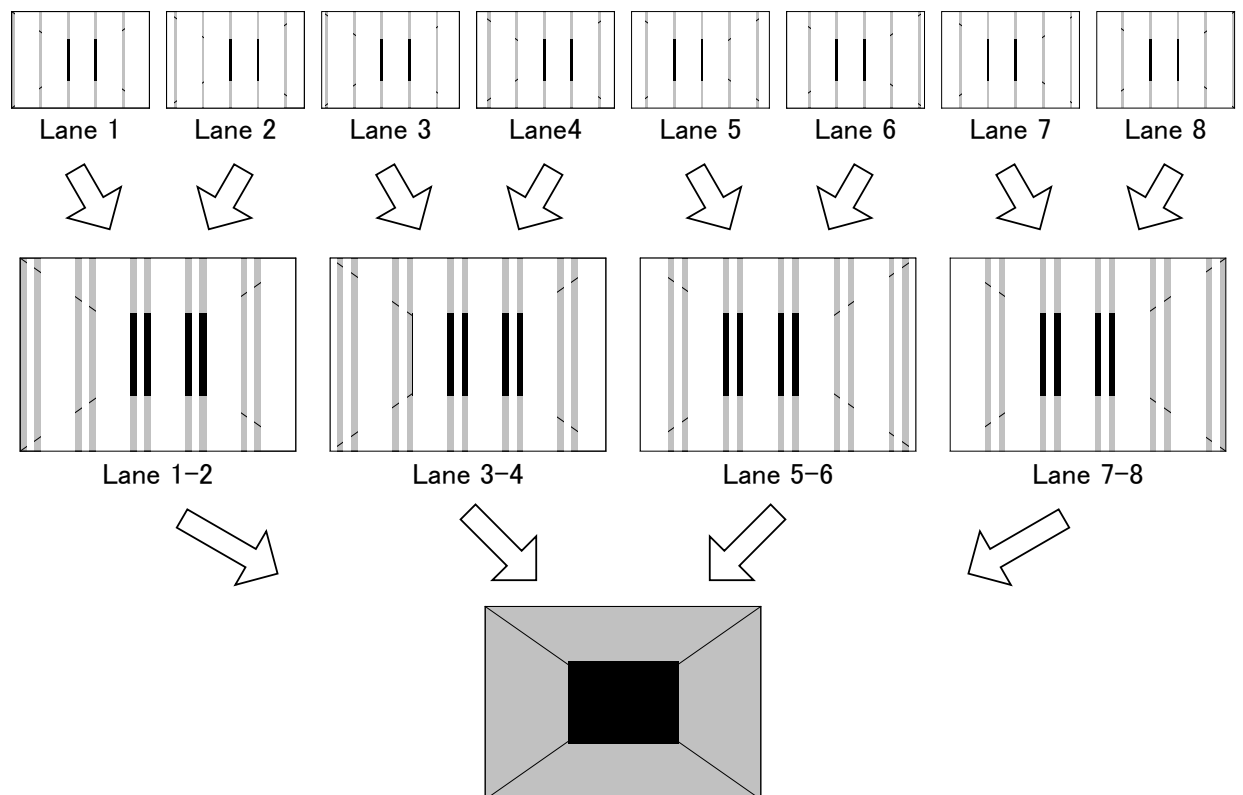
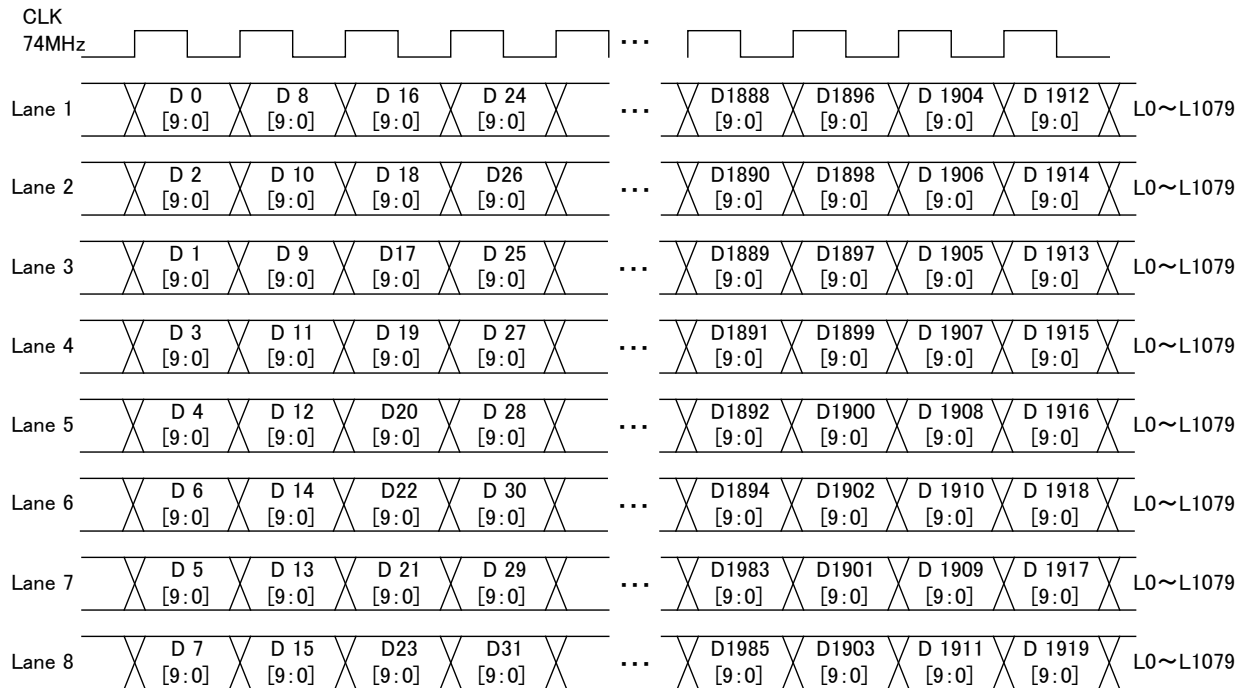

[4] MODE3 (8 Lane) - Dividing Normal Mode

Using lanes 1 - 2 lanes and 3- 4 lanes, the left half of the image is output in the even and odd numbers; similarly, using 5-6 lanes and 7- 8 lanes, the right half of the image is output in the even and odd numbers.

This example is a case where the resolution is 1920 × 1080, the dot clock frequency is 592 MHz and the output bit depth is 10 bits.

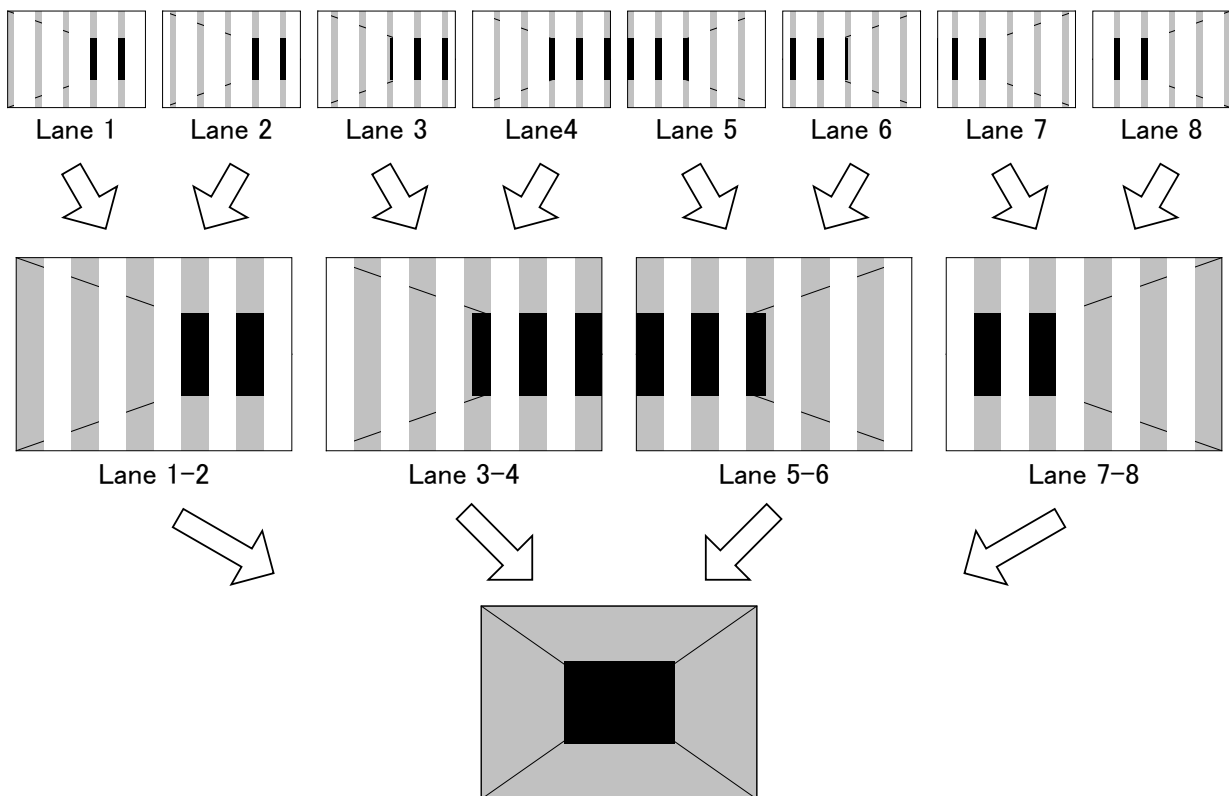
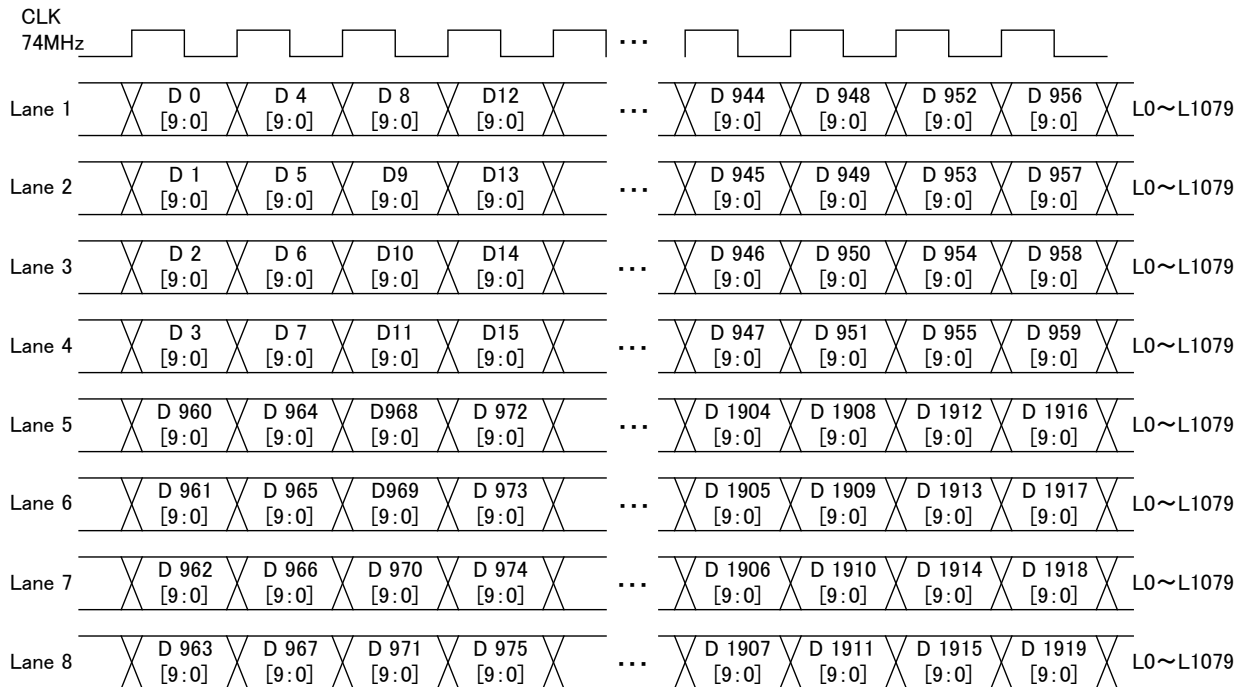

[5] MODE4 (8 Lane) - Dividing Cross Mode (same as 4Kx2K MODE3)

Using lanes 1 -3 lanes and 2- 4 lanes, the left half of the image is output in the even and odd numbers; similarly, using 5-7 lanes and 6-8 lanes, the right half of the image is output in the even and odd numbers.

This example is a case where the resolution is 1920 × 1080, the dot clock frequency is 592 MHz and the output bit depth is 10 bits.

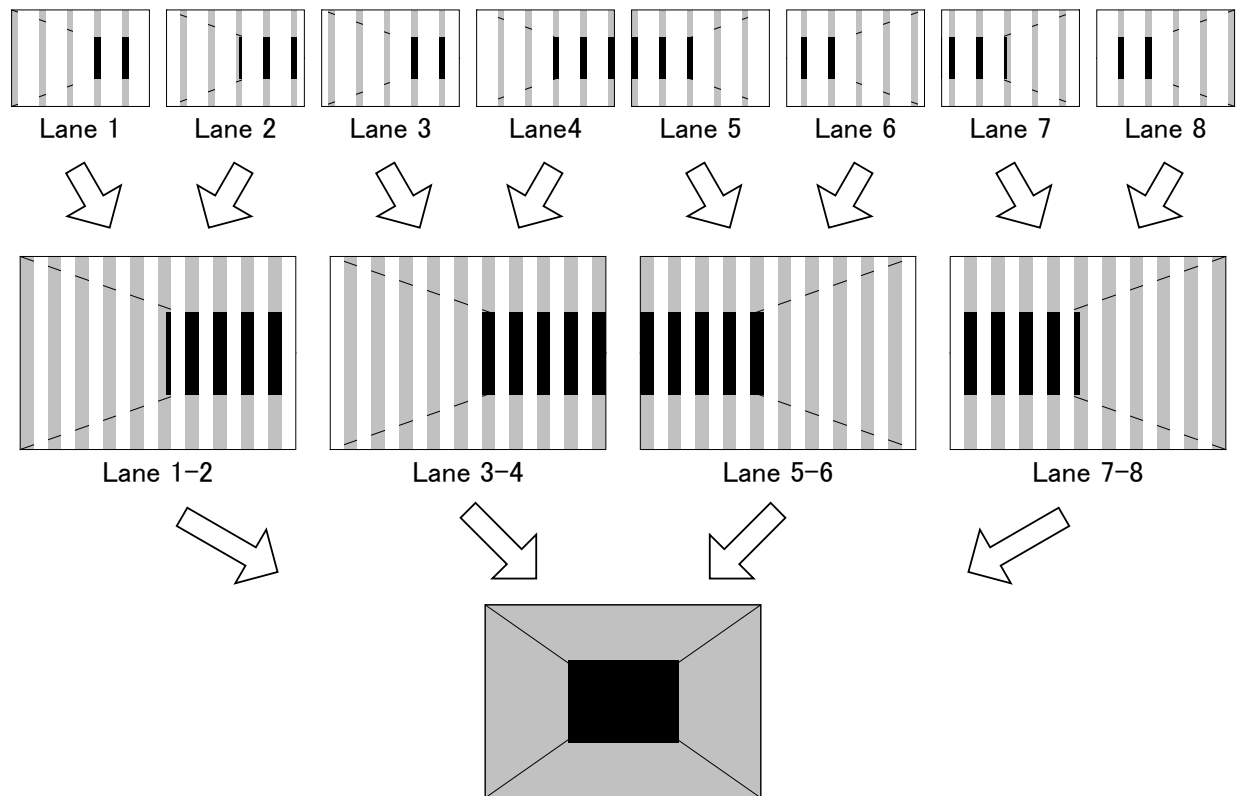
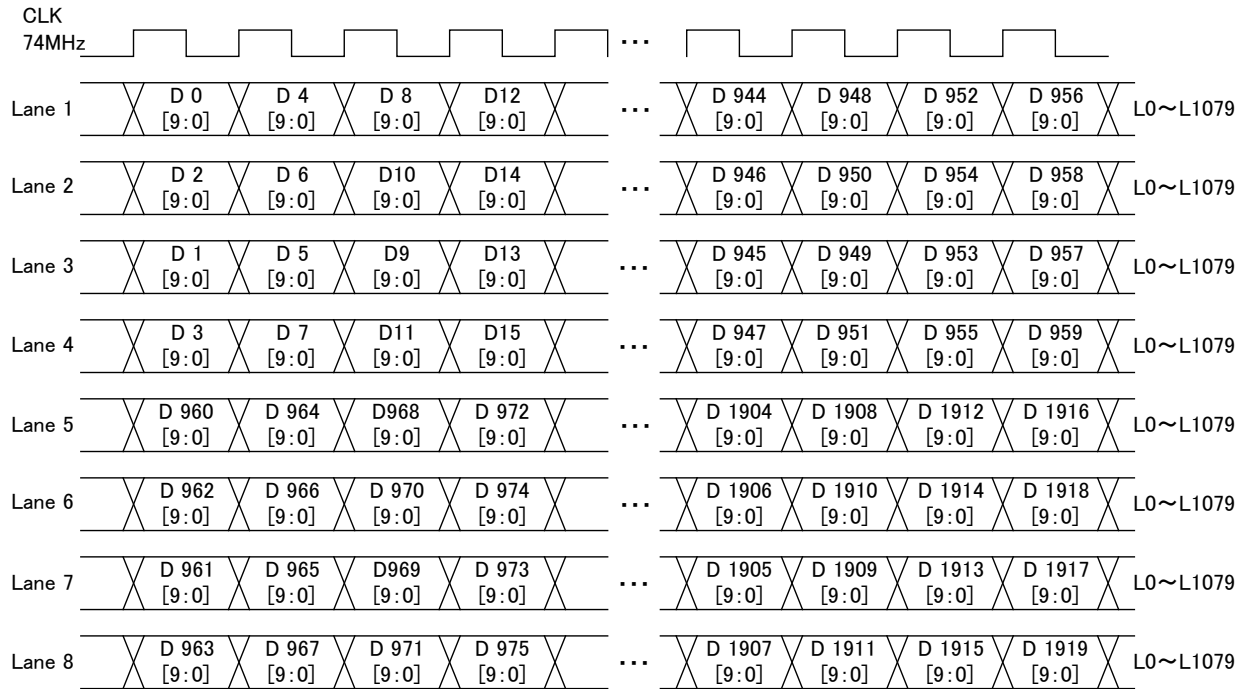

Specifications of 16-lane modes of using VM-1825 x 2 boards mode (4Kx2K 120 Hz mode) output

This mode is an output mode for 4Kx2K 120 Hz testing.

In the 4Kx2K 2-board mode output, 16 lanes are combined using two output boards to output one screen.

- * 1 to 8 lanes are assigned to the lower position of VM-1825 board.
- * 9 to 16 lanes are assigned to the upper position of VM-1825 board..

[4Kx2K 120 Hz - 16-lane output]

[1st board output (lower position)]

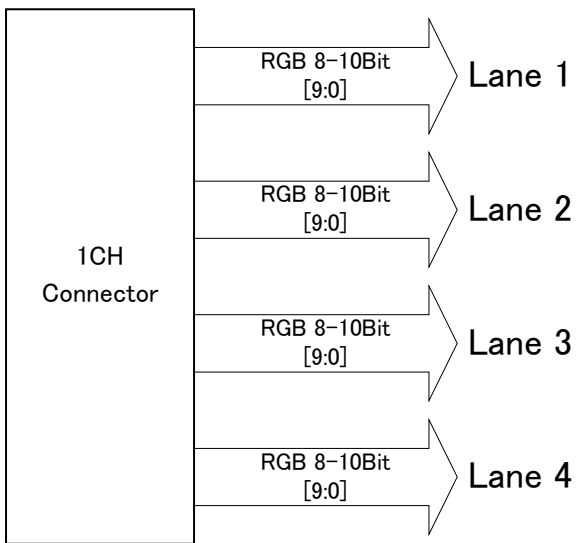

[2nd board output (upper position)]

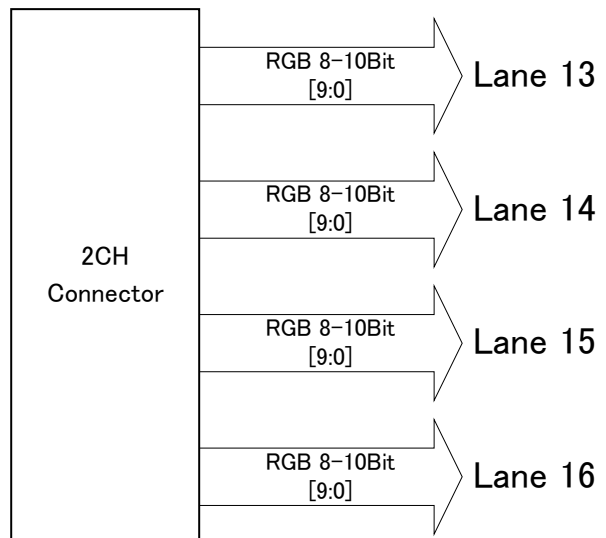
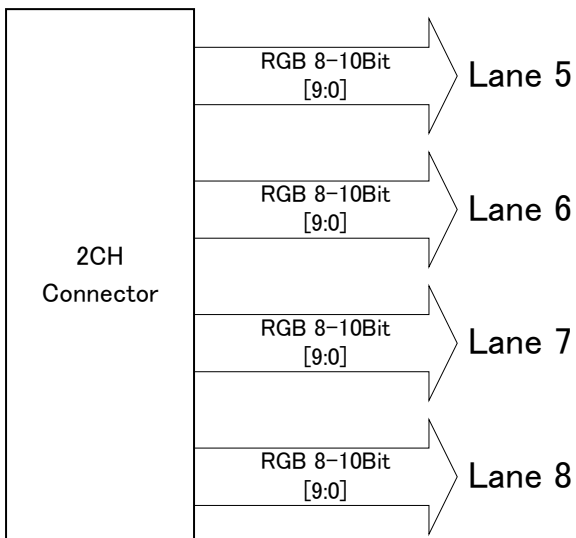
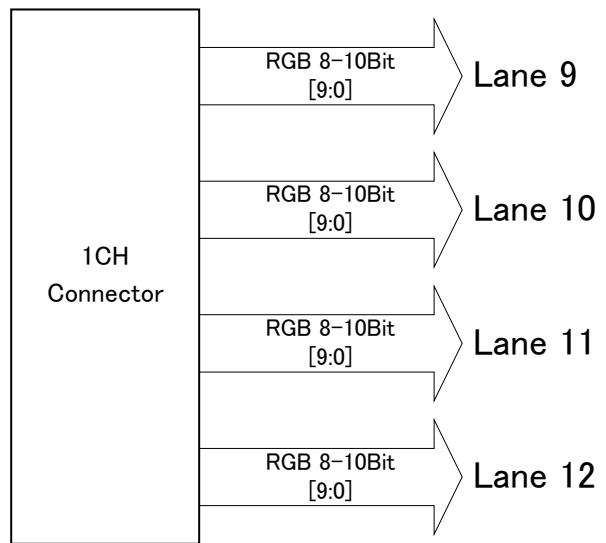

[1] MODE0 (16Lane) (Checker split into 4 + vertically split into 2)

The screen is split it into 4 by checker from each output board , and split vertically into 2 by 2 boards.

This example is a case where the resolution is 4096 × 2048, the dot clock frequency is 1184 MHz and the output bit depth is 10 bits.

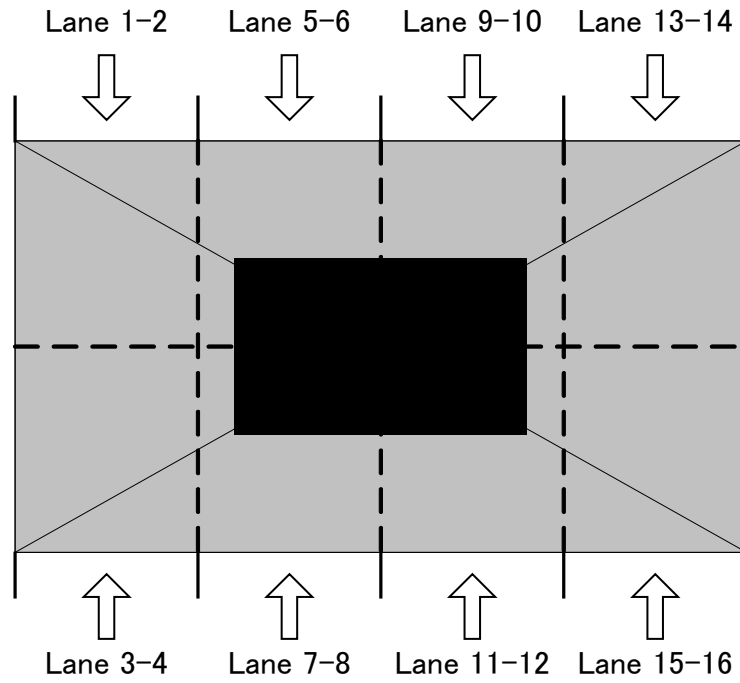
[Assignment of each Lane]

[Pixel Assignment of each Lane]

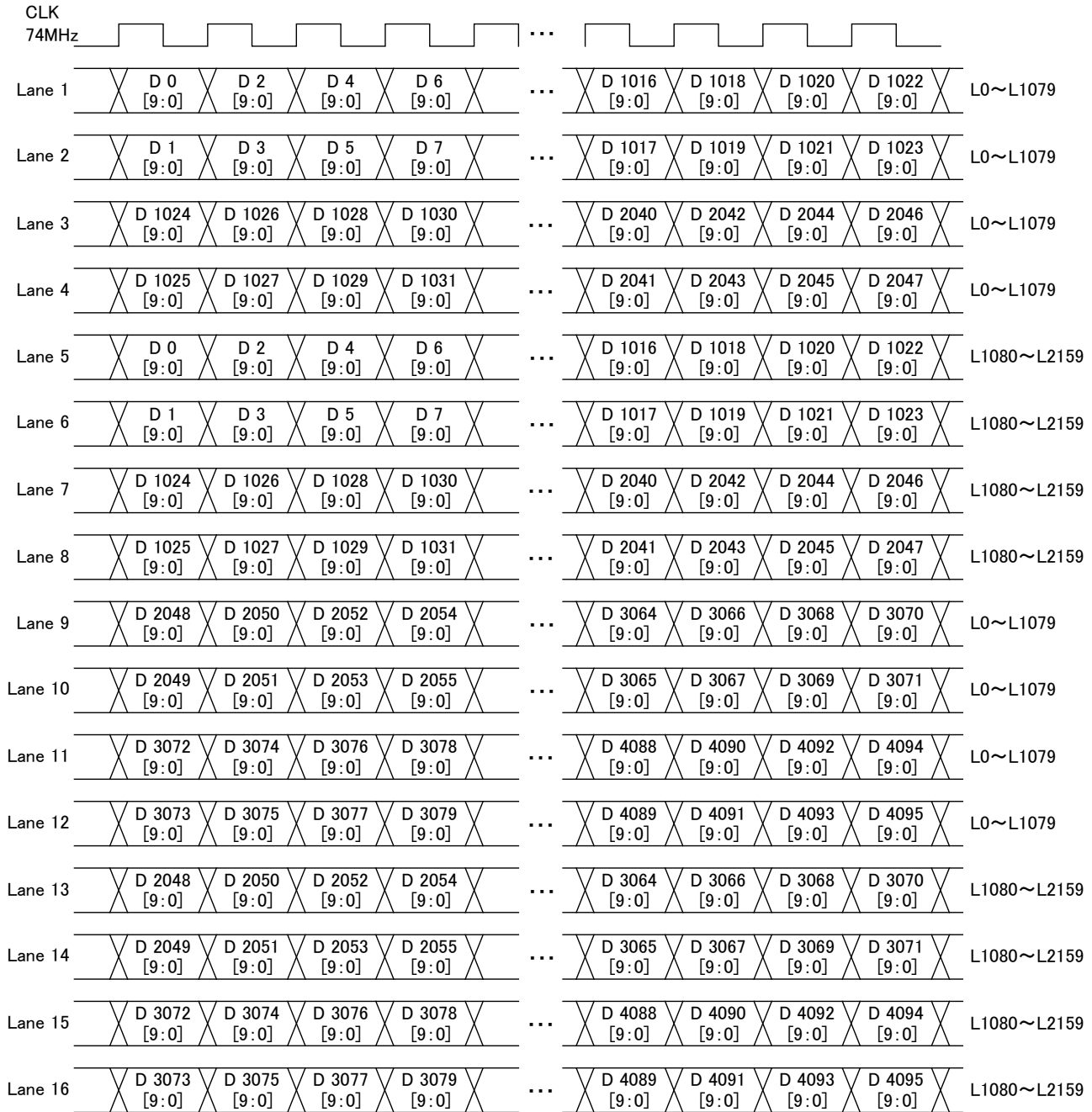

[2] MODE1 (16Lane) (vertically split into 4 + vertically split into 2)

The screen is vertically split into 4 and output from each output board, then it is vertically split into 2 by 2 boards.

This example is a case where the resolution is 4096 × 2048, the dot clock frequency is 1184 MHz and the output bit depth is 10 bits.

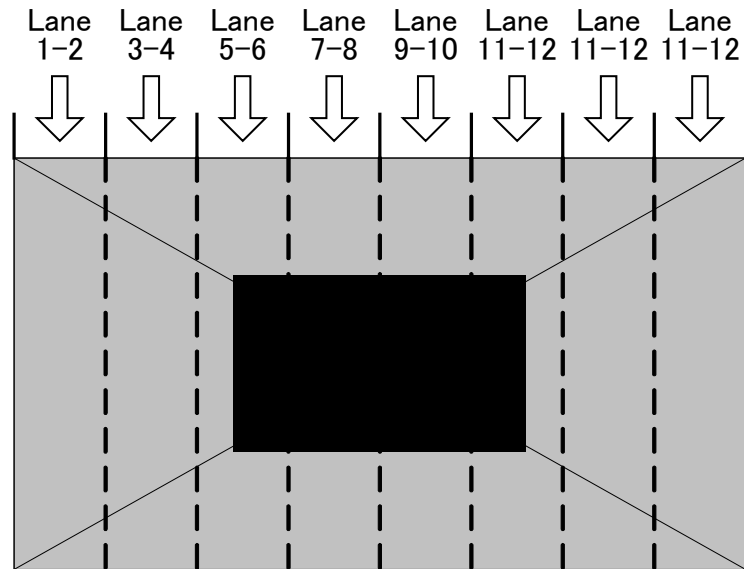
[Assignment of each Lane]

[Pixel Assignment of each Lane]

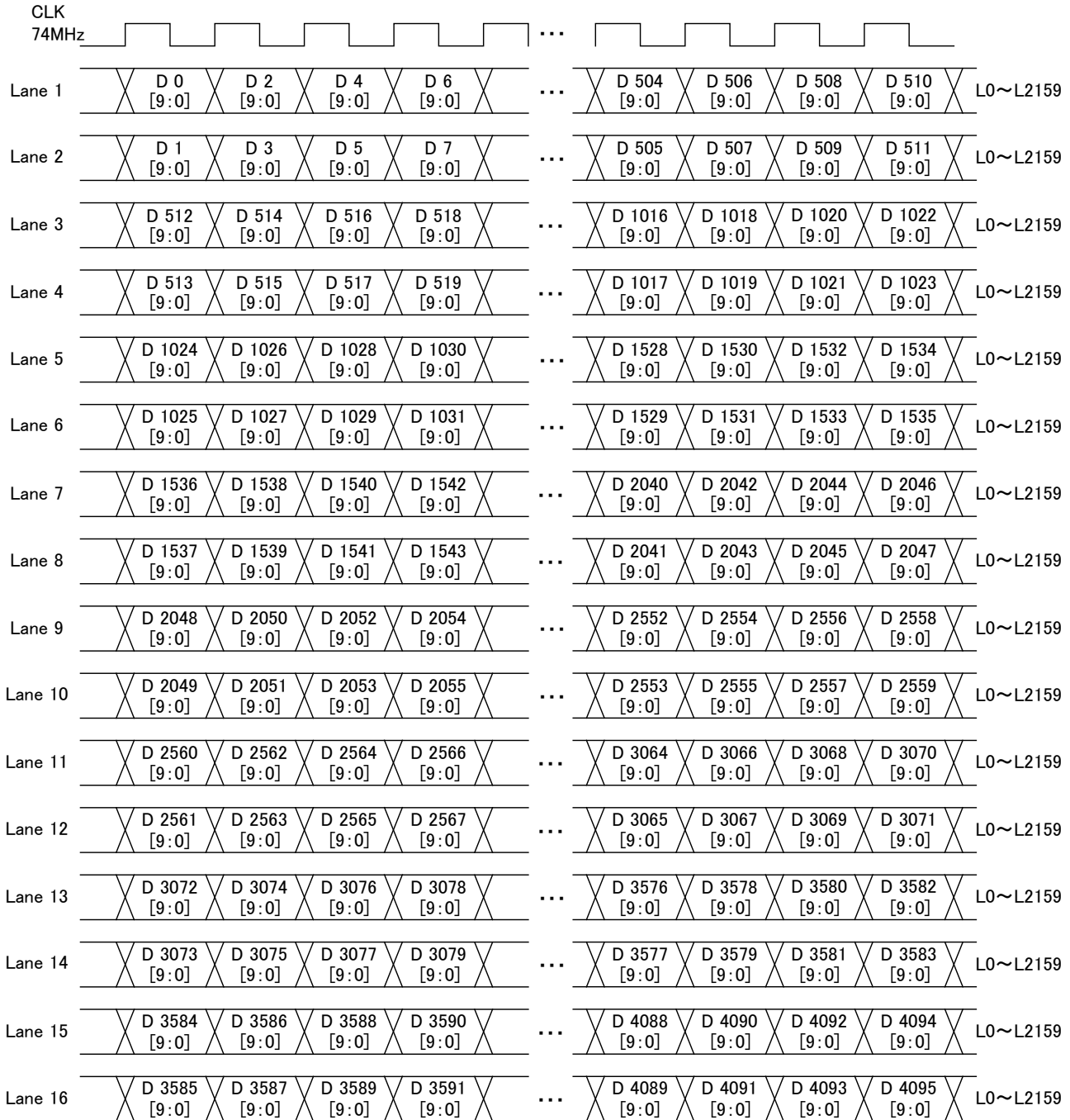

[3] MODE2 (16Lane) (horizontally split into 2 + vertically split into 2)

The screen is horizontally split into 2 and output from each output board, then it is vertically split into 2 by 2 boards.

This example is a case where the resolution is 4096 × 2048, the dot clock frequency is 1184 MHz and the output bit depth is 10 bits.

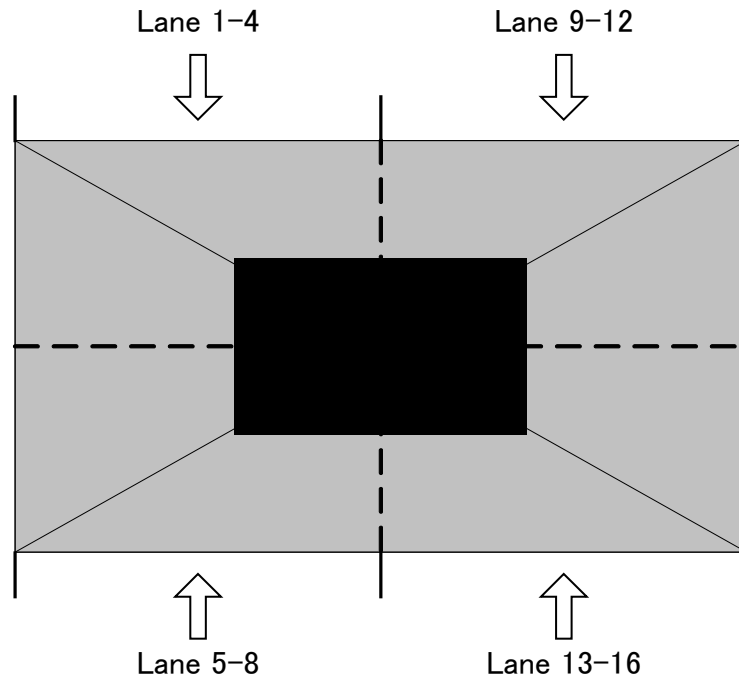
[Assignment of each Lane]

[Pixel Assignment of each Lane]

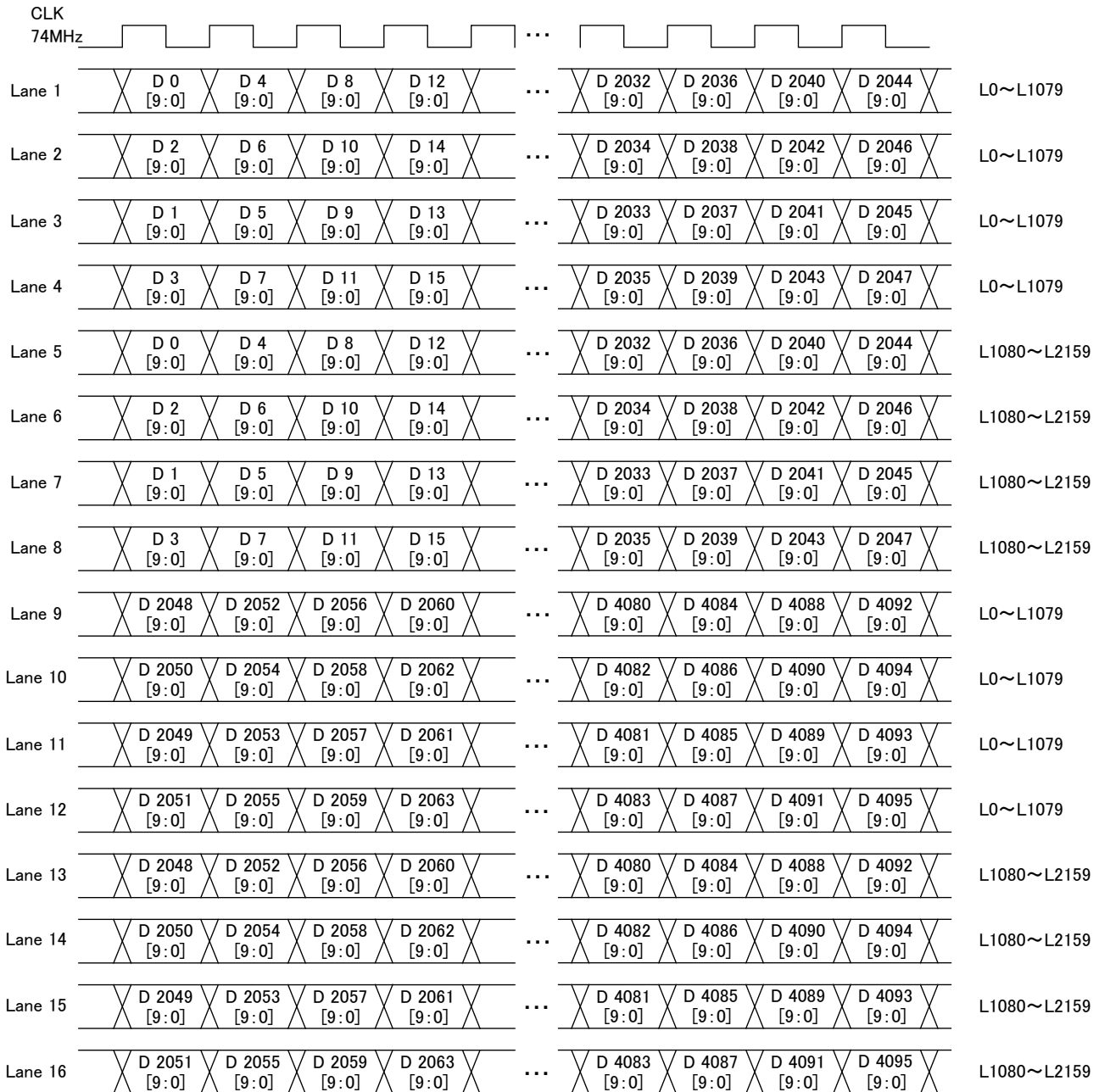

[4] MODE3 (16Lane) (vertically split into 2 + vertically split into 2)

The screen is vertically split into 2 and output from each output board, then it is vertically split into 2 by 2 boards.

This example is a case where the resolution is 4096 × 2048, the dot clock frequency is 1184 MHz and the output bit depth is 10 bits.

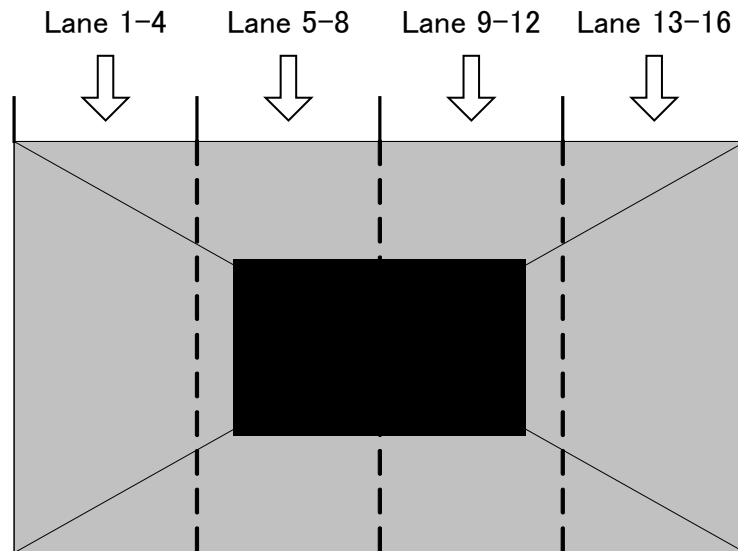
[Assignment of each Lane]

[Pixel Assignment of each Lane]

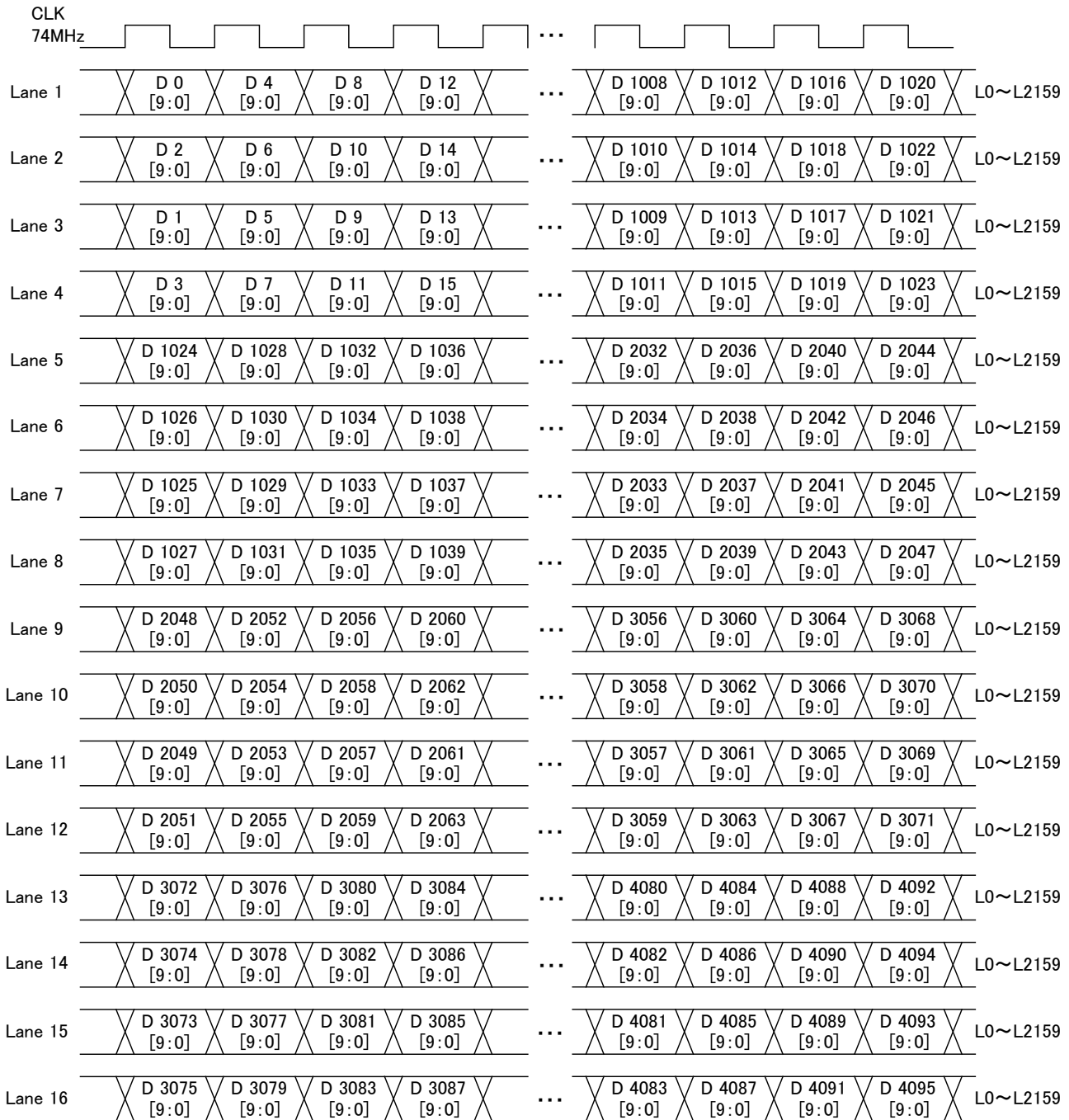

[5] MODE4 (16Lane) (vertically split into 2 + No split (1)) (Non Dividing Mode)

The screen is output according to [Pixel Assignment of each Lane] from each output board, then it is vertically split into 2 by 2 boards.

This example is a case where the resolution is 4096 × 2048, the dot clock frequency is 1184 MHz and the output bit depth is 10 bits.

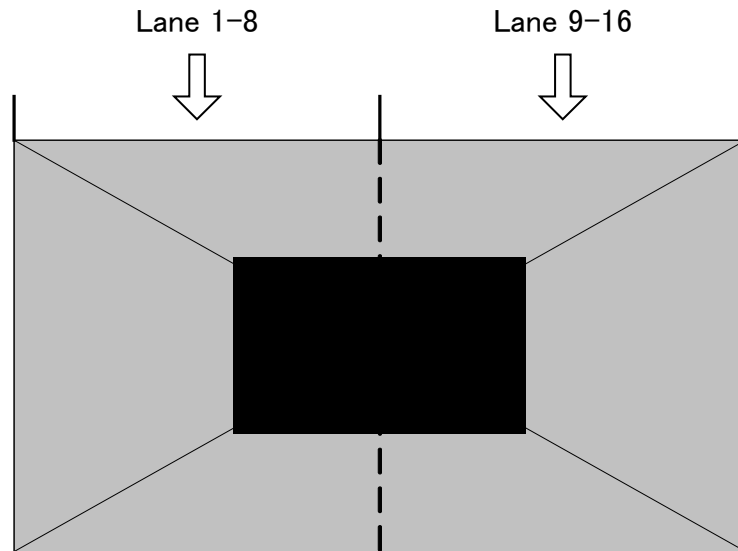
[Assignment of each Lane]

[Pixel Assignment of each Lane]

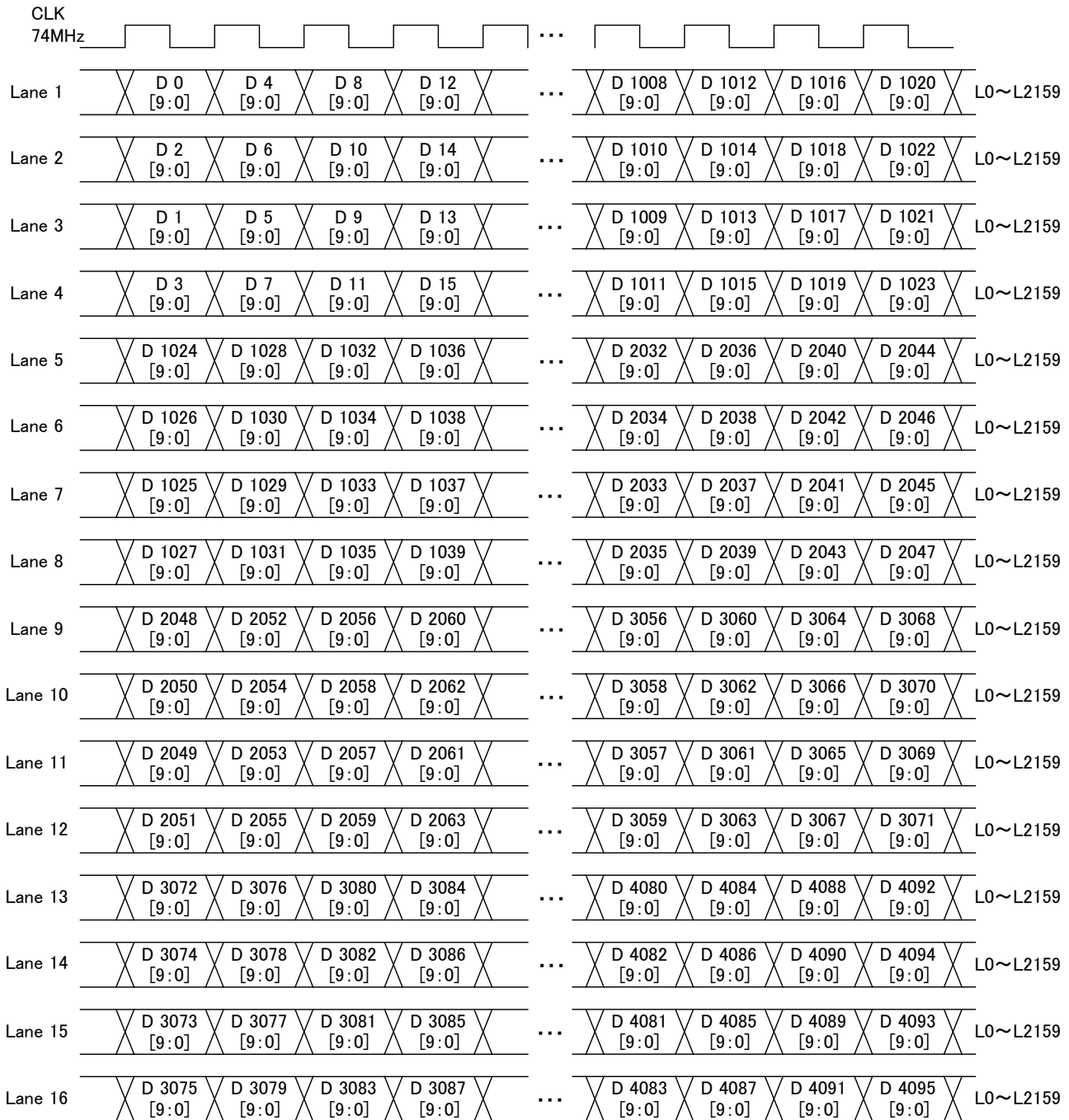

[6] MODE5 (16Lane) (vertically split into 2 + No split (2)) (Normal Mode)

The screen is output according to **[Pixel Assignment of each Lane]** from each output board, then it is vertically split into 2 by 2 boards.

This example is a case where the resolution is 4096 × 2048, the dot clock frequency is 1184 MHz and the output bit depth is 10 bits.

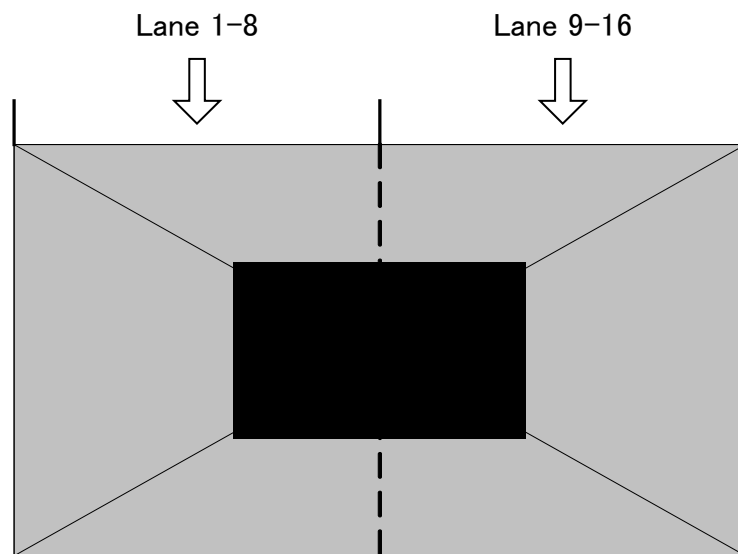
[Assignment of each Lane]

[Pixel Assignment of each Lane]

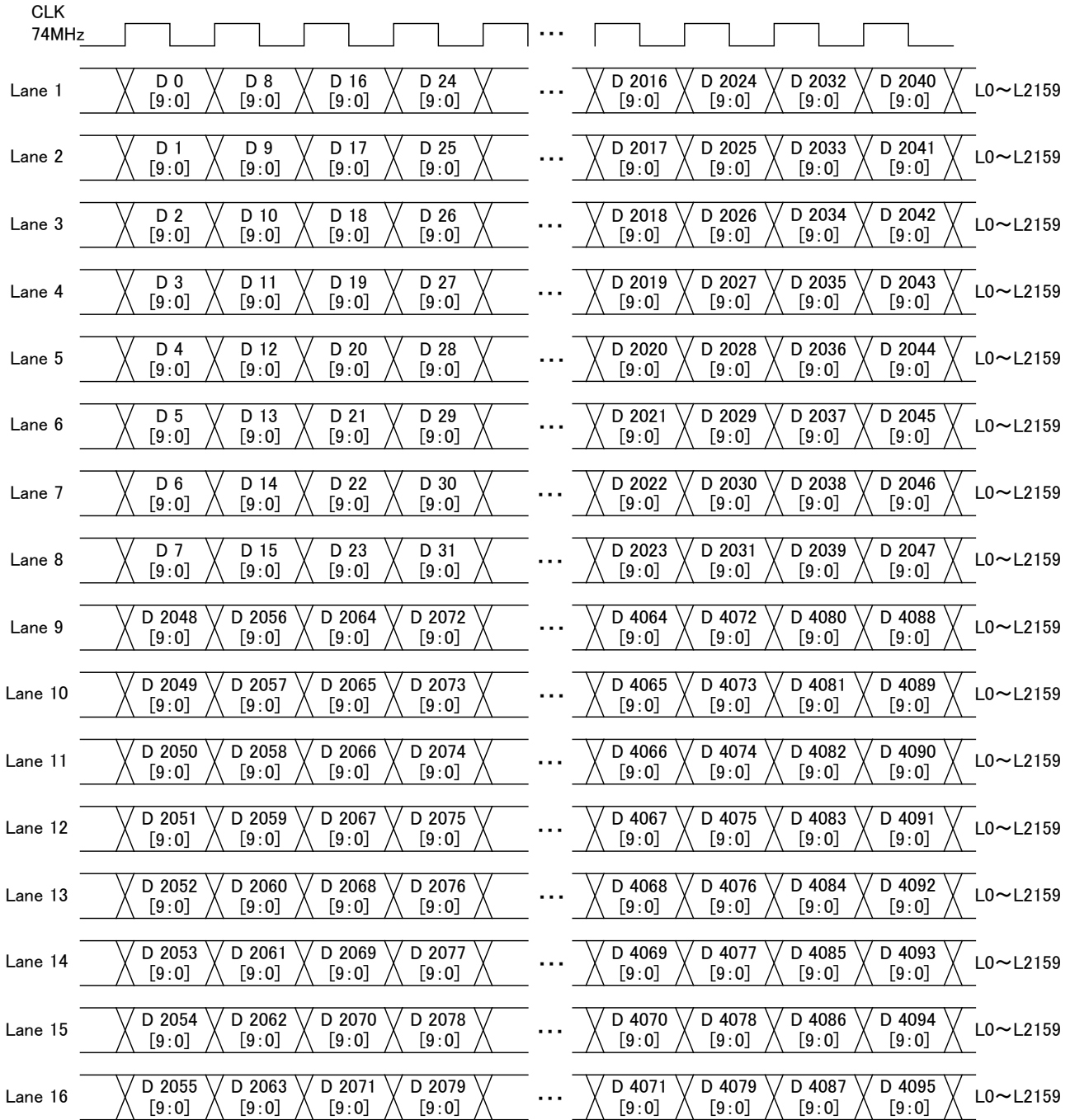

[7] MODE6 (16Lane) (vertically split into 2 + No split (3)) (Cross Mode)

The screen is output according to **[Pixel Assignment of each Lane]** from each output board, then it is vertically split into 2 by 2 boards.

This example is a case where the resolution is 4096×2048 , the dot clock frequency is 1184 MHz and the output bit depth is 10 bits.

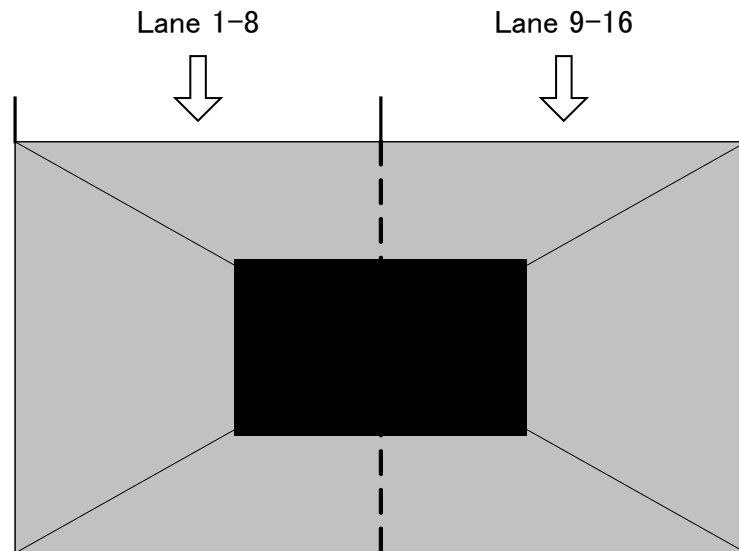
[Assignment of each Lane]

[Pixel Assignment of each Lane]

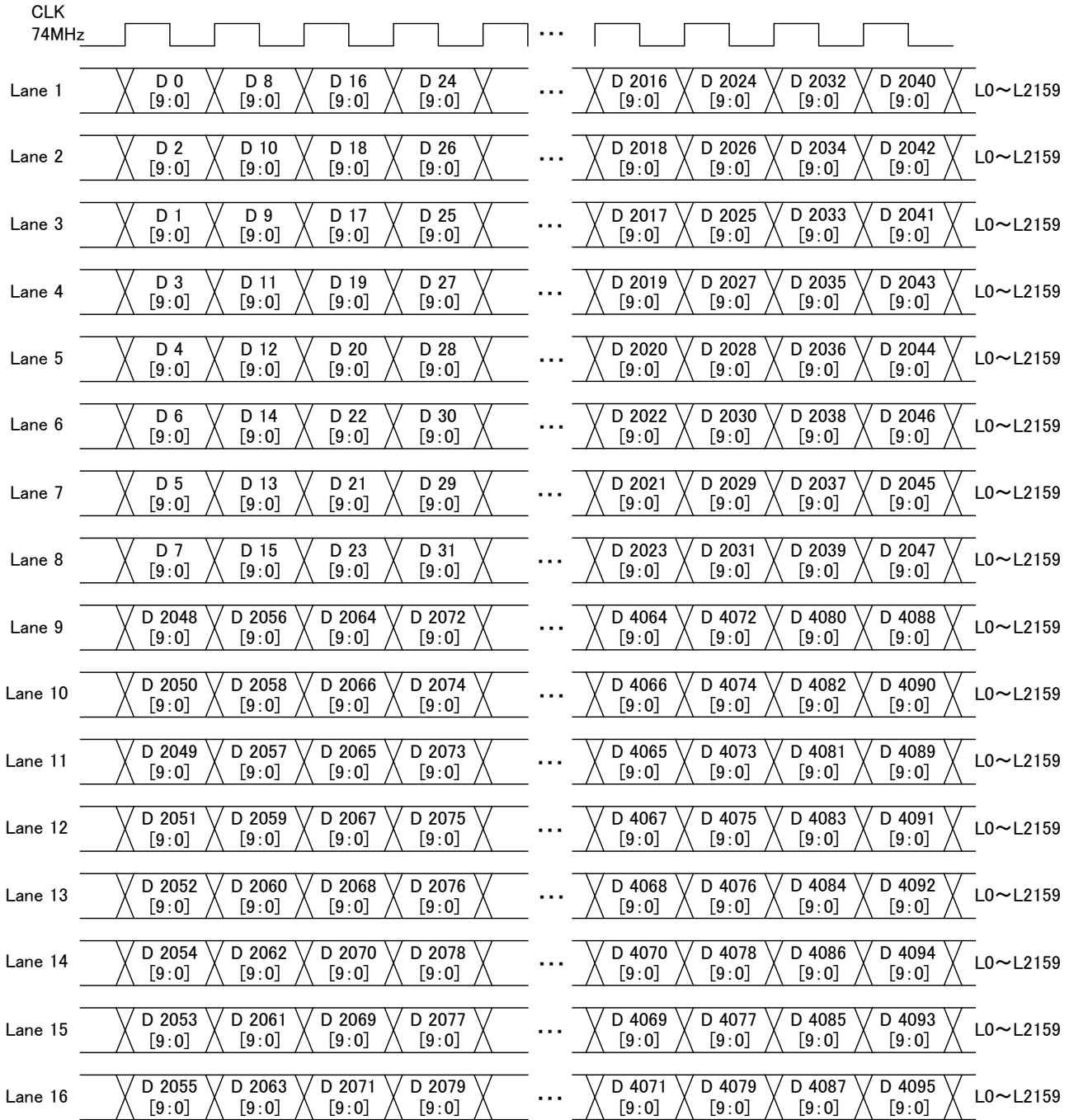

[8] MODE7 (16Lane) (vertically split into 2 + Split (1)) (Dividing Normal Mode)

The screen is vertically divided into 2 and is output according to **[Pixel Assignment of each Lane]** from each output board, then it is vertically split into 2 by 2 boards.

This example is a case where the resolution is 4096 × 2048, the dot clock frequency is 1184 MHz and the output bit depth is 10 bits.

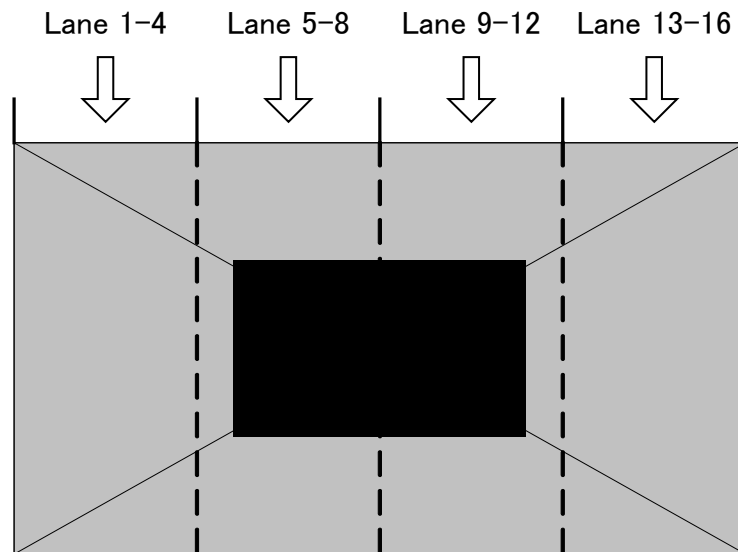
[Assignment of each Lane]

[Pixel Assignment of each Lane]

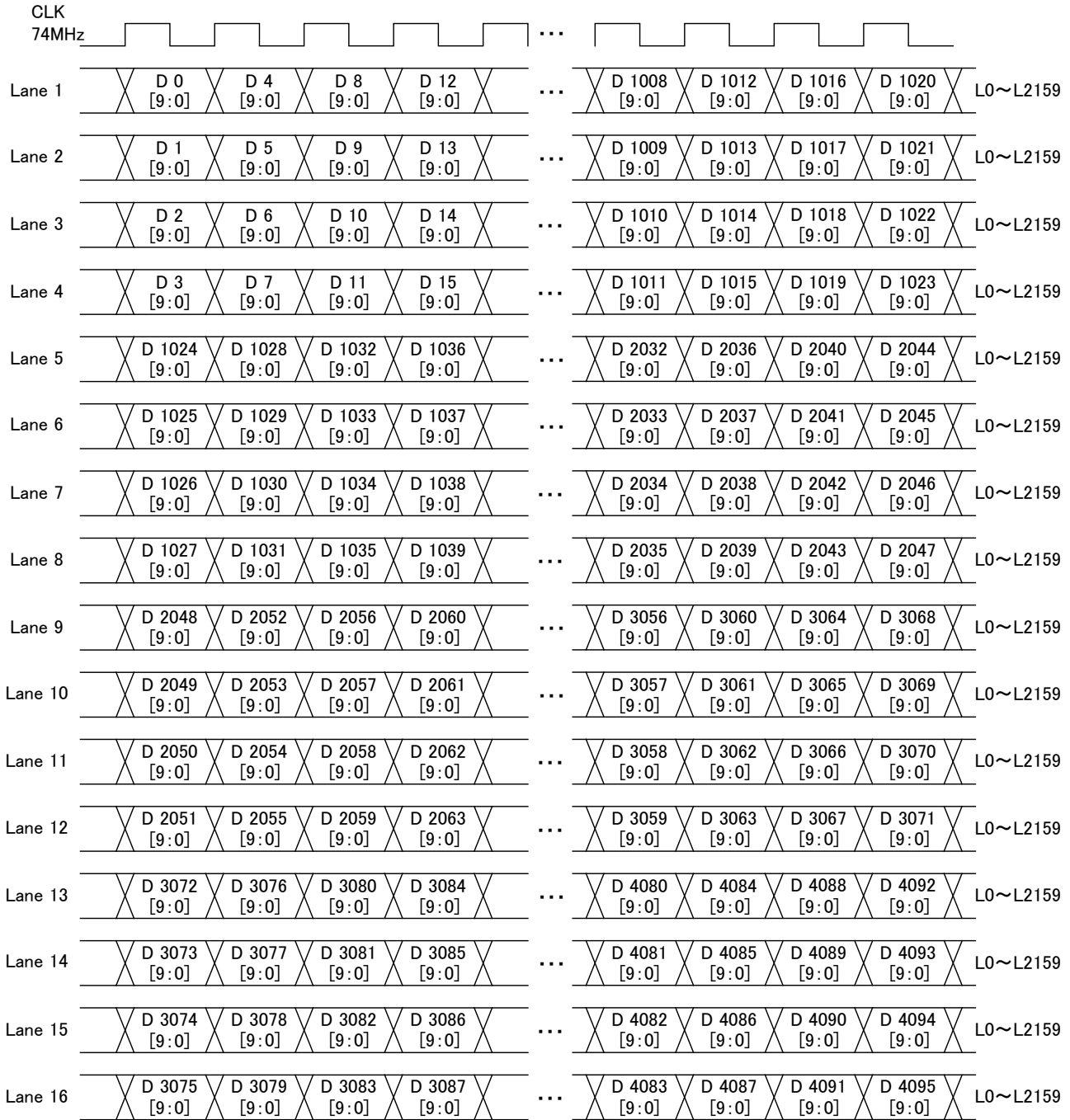

[9] MODE8 (16Lane) (vertically split into 2 + Split (2)) (Dividing Cross Mode)

The screen is vertically divided into 2 and is output according to **[Pixel Assignment of each Lane]** from each output board, then it is vertically split into 2 by 2 boards.

This example is a case where the resolution is 4096 × 2048, the dot clock frequency is 1184 MHz and the output bit depth is 10 bits.

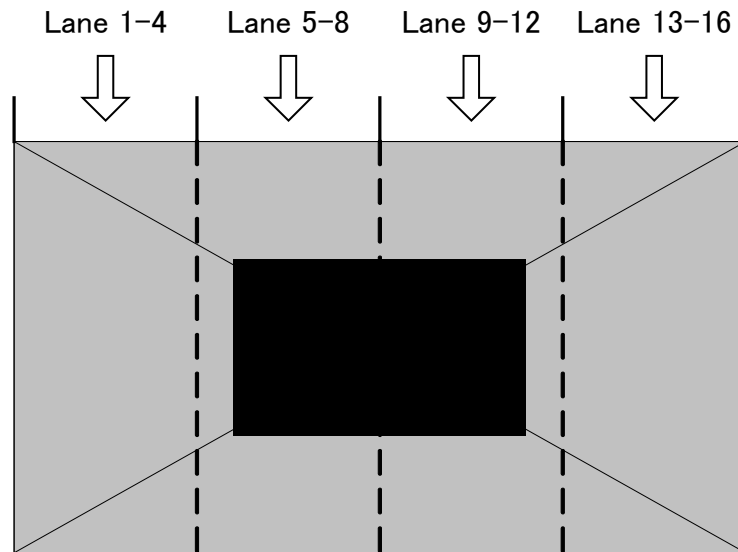
[Assignment of each Lane]

[Pixel Assignment of each Lane]

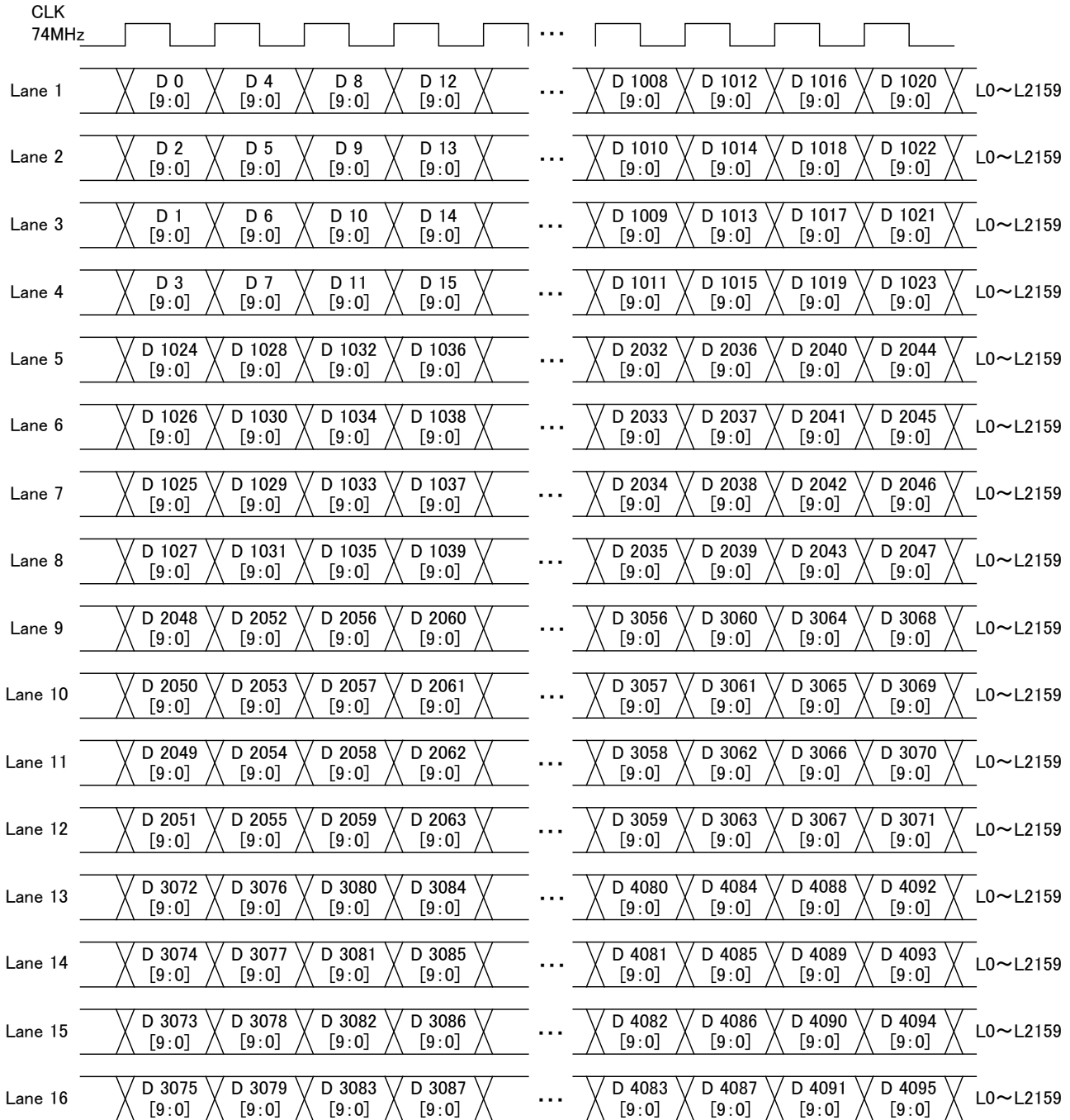

[10] MODE9 (16Lane) (No Split)

Without splitting the screen, it is output according to **[Pixel Assignment of each Lane]** from each output board.

This example is a case where the resolution is 4096 × 2048, the dot clock frequency is 1184 MHz and the output bit depth is 10 bits.

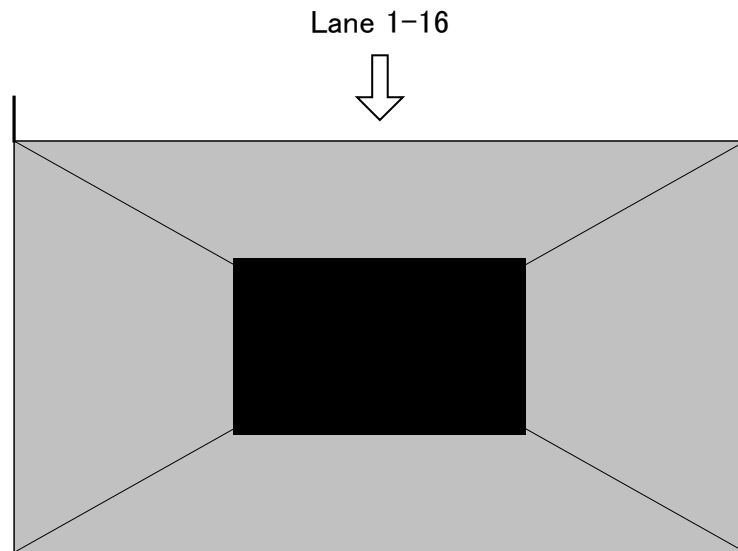
[Assignment of each Lane]

[Pixel Assignment of each Lane]

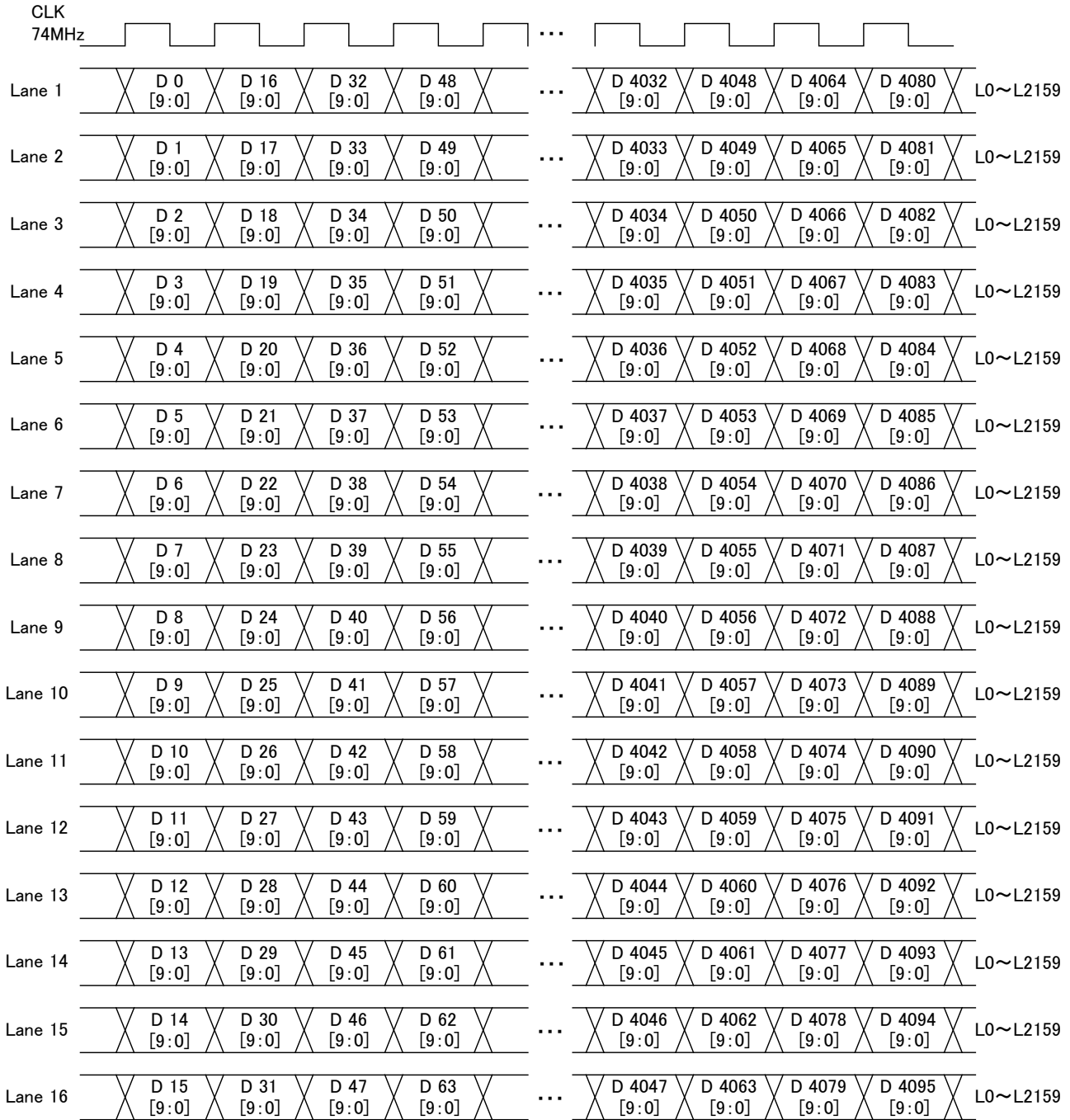

4.13.4 V-by-One HS Control

The VM-1825 makes it possible to control the V-by-One HS control signals (HTPDN and LOCKN).

<Operating procedure>

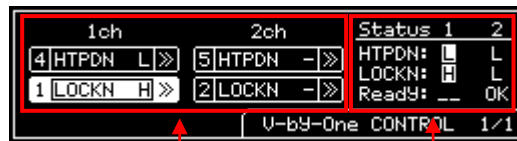
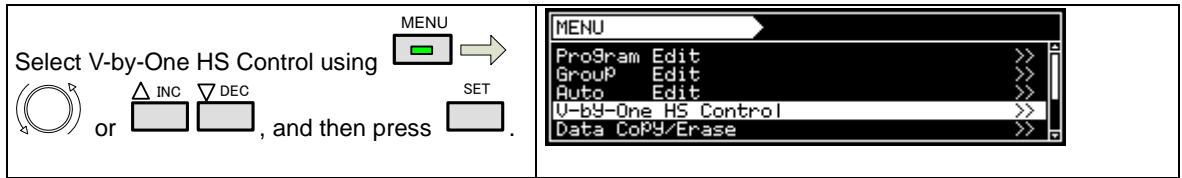

(1)

(2)

<Control parameters>







































(1)	These parameters are used for channel 1 and channel 2 control.	
	- Through	The signals from the receiver are passed straight through.
	L Forced Low	The signal is forcibly set to low.
	H Forced High	The signal is forcibly set to high.
(2)	The current statuses of channel 1 and channel 2 are indicated here. The statuses are displayed in solid white lettering against a black background if the signals have been forcibly set to low or high.	

4.14 SDI (VM-1821)

4.14.1 Concerning the SDI output

Only timings complying with the SDI compatible standard (SMPTE) concerned are output as the SDI output. For details, refer to "11.1.11 SDI unit."

4.14.2 SDI setting procedure

<p>(1) Select Program Edit using    or  INC  DEC  , and then press .</p>	
<p>(2) Select Output (TIM) using  or  INC  DEC  , and then press .</p>	
<p>(3) Select Digital Output using  or  INC  DEC  , and then press .</p>	
<p>(4) Select DP using  or  INC  DEC  , and then press .</p>	
<p>(5) Select the items using  or  INC  DEC  , and then press .</p> <p><Inputting the parameters></p> <p>Select the parameters using  or  INC  DEC  , and then press .</p> <p>Alternatively: Select the parameters using the number keys ( to ), and then press .</p>	<p>For details on the parameters, refer to <SDI unit setting parameters> on the next page.</p>

<SDI unit setting parameters>

(1)	Output 1,2ch (0/1) Output 3,4ch (0/1)	This sets On or Off for each channel. (The same settings apply to channels 1 and 2 and to channels 3 and 4.) These are the same settings as in “4.1.1 Setting the output interfaces to ON or OFF.”	
		0	OFF No output.
		1	ON Output.
(2)	SDI Format (0-5)	This sets the SDI format. * The format which is supported differs depending on the timing. For details, refer to “11.1.11 SDI unit.”	
		0	SD SD-SDI
		1	HD HD-SDI
		2	3G-A 3G-SDI. Level.A
		3	3G-B 3G-SDI. Level.B
		4	Dual Dual-Link
		5	3D 3D (Option) * “3D” is an option. When the requisite license has not been registered, sending using 3D is not possible. For details, consult with an ASTRODESIGN sales representative or your distributor.
(3)	Video Format (0-2)	This sets the color space of the images which are output from SDI. * The format which is supported differs depending on the timing. For details, refer to “11.1.11 SDI unit.”	
		0	RGB RGB
		1	YCbCr4:4:4 YCbCr4:4:4
		2	YCbCr4:2:2 YCbCr4:2:2
(4)	Width(0-4)	This sets the output image bit length. A setting which is independent of the pattern drawing bit length can be selected or the same bit length as the pattern drawing bit length can be selected automatically. * The portion of the pattern drawing bit length which exceeds the bit length set here is discarded. A deficient portion is filled with zeros. Refer to “4.1.5 Setting the bit length (gray scale) for pattern drawing.” * The format which is supported differs depending on the timing. For details, refer to “11.1.11 SDI unit.”	
		0	Auto Either 10 bits or 12 bits are selected automatically in accordance with the pattern drawing bit length.
		1	10bit 10-bit output
		2	12bit 12-bit output
(5)	Audio Output(0/1)	This sets the embedded audio output. * For details on the embedded audio settings, refer to “4.2.5 Embedded audio, high bit rate audio (option).”	
		0	OFF The embedded audio is not output.
		1	ON The embedded audio is output.
(6)	Payload	This sets the payload ID data. For further details, refer to <SDI payload ID data setting parameters> in the next section.	

<SDI payload ID data setting parameters>

* These settings are for the payload ID data only. For details of the settings which directly affect the transfer signals, refer to the respective items.

(1)	OFF/ON (0/1)	This sets the payload ID data to ON or OFF.		
		0	OFF	The payload ID data is not inserted.
		1	ON	The payload ID data is inserted.
(2)	Mode (0/1)	This is the setting for Byte1, Channel Assignment.		
		0	Refer Program	According to each data setting, the setting value of Bye1 and Channel Assignment is followed. Note) Byte1 and Channel Assignment1, Channel Assignement2 are not displayed.
		1	Manual	Byte1 and Channel Assignment are set by manually.
(3)	Byte1	Set Byte1. Note) this is available only when Mode is set by "1 (manual)" 00 – FF		
(4)	Transport (0/1)	This sets the transport scanning mode.		
		0	Interlace	Interlace scanning
		1	Progressive	Progressive scanning
(5)	Picture (0/1)	This sets the image scanning mode.		
		0	Interlace	Interlace scanning
		1	Progressive	Progressive scanning
(6)	Picture Rate(0-7)	This sets the frame rate.		
		0	23.98Hz	The frame rate of each value is used as the setting.
		1	24Hz	
		2	25Hz	
		3	29.97Hz	
		4	30Hz	
		5	50Hz	
		6	59.94Hz	
		7	60Hz	
(7)	Aspect Ratio(0/1)	This sets the aspect ratio.		
		0	4:3	4:3 aspect ratio
		1	16:9	16:9 aspect ratio
(8)	H Y-Sampling (0/1)	This sets the Y sampling value.		
		0	0	
		1	1	
(9)	Sampling Struck(0-4)	This set the sampling structure (video format)		
		0	4:2:2(YCbCr)	The video format of each value is used as the setting.
		1	4:4:4(YCbCr)	
		2	4:4:4(RGB)	
		3	4:4:4:4(YCbCr+A)	
		4	4:4:4:4(RGB+A)	
5	4:4:4 (XYZ)			
(10)	Channel Assignment 1 (0-3)	Set channel of Data stream 1. Note) this is available only when Mode is set by "1 (manual)"		
		0	1ch	
		1	2ch	
		2	3ch	
		3	4ch	

(10)	Channel Assignment 2 (0-3)	Set channel of Data stream 2. (this is valid for Dual Link / 3G Level B). Note) this is available only when Mode is set by "1 (manual)"		
		0	1ch	The dynamic range of each value is used as the setting.
		1	2ch	
		2	3ch	
		3	4ch	
(11)	Dynamic Range(0-2)	This sets the dynamic range.		
		0	100%	The dynamic range of each value is used as the setting.
		1	200%	
		2	400%	
(12)	Bit Depth(0-2)	This sets the bit length.		
		0	8bit	The bit length of each value is used as the setting.
		1	10bit	
		2	12bit	

4.14.3 Embedded audio

The embedded audio can be output as the SDI output.

For details of the setting procedure, refer to "4.16 Digital audio."

4.15 Analog audio settings

4.15.1 Connectors and output signals



Connector	Signal
R	Audio right (R) channel
L	Audio left (L) channel

4.15.2 Analog audio signals

Analog audio signals can be output.





























The operation procedure is described below.

- Set the analog audio to enable.
- Set the sound source, frequency, level, etc.

a) Setting the analog audio to enabled

(1)	Select Program Edit using or , and then press .							
(2)	Select Output (TIM) using or , and then press .							
(3)	Select Analog Output using or , and then press .							
(4)	Select TV AUDIO using or , and then press .							
(5)	Select Output (TIM) using or , and then press .	The analog audio output is set to enabled or disabled. <table border="1"> <tbody> <tr> <td>0</td> <td>OFF</td> <td>Disabled</td> </tr> <tr> <td>1</td> <td>ON</td> <td>Enabled</td> </tr> </tbody> </table>	0	OFF	Disabled	1	ON	Enabled
0	OFF	Disabled						
1	ON	Enabled						

b) Setting the sound source, frequency, level, etc.

<p>(1) Select Program Edit using    or  , and then press .</p>	 <pre> MENU Program Edit Program Name : ▶EIA1920x1080P060 Timing < TIM > Output < TIM > Audio < TIM > Pattern < PAT > </pre>								
<p>(2) Select Audio using  or  , and then press .</p>	 <pre> MENU Audio Analog Audio >>> Digital Audio >>> Audio Sweep >>> </pre>								
<p>(3) Select Analog Audio using  or  , and then press .</p>	 <pre> MENU Analog Audio Frequency L : ▶ 1000Hz : 1000Hz Level L R : 0mV R : 0mV </pre>								
<p>(4) Select the items using  or  , and then press .</p> <p><Inputting the parameters></p> <p>Select the parameters using  or  , and then press .</p> <p>Alternatively: Select the parameters using the number keys ( to ) , and then press .</p>	<p>Set the frequency and level.</p> <table border="1"> <tbody> <tr> <td data-bbox="857 752 1062 842">Frequency L</td> <td data-bbox="1062 752 1497 842">The left channel frequency is set. Setting range: 20 Hz to 20,000 KHz (20 Hz Step)</td> </tr> <tr> <td data-bbox="857 842 1062 931">Frequency R</td> <td data-bbox="1062 842 1497 931">The right channel frequency is set. Setting range: 20 Hz to 20,000 KHz (20 Hz Step)</td> </tr> <tr> <td data-bbox="857 931 1062 1021">Level L</td> <td data-bbox="1062 931 1497 1021">The left channel level is set. Setting range: 0 to 4,000 [mV] (50 mV Step)</td> </tr> <tr> <td data-bbox="857 1021 1062 1164">Level R</td> <td data-bbox="1062 1021 1497 1164">The right channel level is set. Setting range: 0 to 4,000 [mV] (50 mV Step)</td> </tr> </tbody> </table>	Frequency L	The left channel frequency is set. Setting range: 20 Hz to 20,000 KHz (20 Hz Step)	Frequency R	The right channel frequency is set. Setting range: 20 Hz to 20,000 KHz (20 Hz Step)	Level L	The left channel level is set. Setting range: 0 to 4,000 [mV] (50 mV Step)	Level R	The right channel level is set. Setting range: 0 to 4,000 [mV] (50 mV Step)
Frequency L	The left channel frequency is set. Setting range: 20 Hz to 20,000 KHz (20 Hz Step)								
Frequency R	The right channel frequency is set. Setting range: 20 Hz to 20,000 KHz (20 Hz Step)								
Level L	The left channel level is set. Setting range: 0 to 4,000 [mV] (50 mV Step)								
Level R	The right channel level is set. Setting range: 0 to 4,000 [mV] (50 mV Step)								

4.16 Digital audio

4.16.1 Digital audio

The embedded audio and high-bit-rate audio (HDMI only) can be superimposed and output from the HDMI and DisplayPort connectors. The high-bit-rate audio is optionally supported. For further details, contact an ASTRODESIGN sales representative or your dealer.

The audio sources supported for each output are listed in the table below.

Audio Source		HDMI		DisplayPort			SDI
		VM-1817	VM-1822 (ARC) VM-1823	VM-1820	VM-1820A	VM-1826	
Ext. Optical	External digital input (optical)	OK	N/A	OK (Max. 96KHz) *1	N/A	N/A	N/A
Ext. COAXIAL	External digital input (coaxial)	OK		N/A	OK (Max. 96KHz) *1	OK	N/A
Ext. Analog to L-PCM	External analog input (L-PCM output)	OK	N/A	N/A	N/A	N/A	N/A
Ext. Analog to DSD	External analog input (DSD output)	OK	N/A	N/A	N/A	N/A	N/A
Int. L-PCM	Internal output (L-PCM)	OK		OK (Max. 96KHz) *1	OK (Max. 96 kHz) *1	OK	OK (48kHz) *2
Int. Non L-PCM	Internal output (non-L-PCM, memory incorporated)	Option		N/A	N/A	N/A	N/A
Int. L-PCM (Flash)	Internal output (non-L-PCM, memory incorporated)	Option		N/A	N/A	N/A	N/A
Int. DSD	Internal output (DSD)	Option		N/A	N/A	N/A	N/A
Ext. I2S L-PCM	External I2S input (L-PCM)	Option		N/A	N/A	N/A	N/A
Ext. I2S Non L-PCM	External I2S input (non-L-PCM)	Option		N/A	N/A	N/A	N/A

“OK”: Supported

“N/A”: Not supported (output is set to OFF even it is selected)

“Option”: Optionally supported (For further details, contact ASTRODESIGN sales representative or your dealer.)



















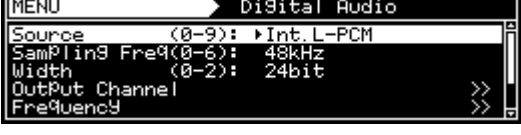

Note)

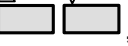
*1 Maximum sampling rate of DisplayPort (VM-1820 / 1820A) is 96 kHz.





*2 The sample rate with SDI outputs is fixed at 48 kHz for all the settings.

The operation procedure is described below.

Setting the sound source, frequency, level, etc.

<p>(1) Select Program Edit using  or , and then press .</p>	
<p>(2) Select Audio (TIM) using  or , and then press .</p>	
<p>(3) Select Digital Audio using  or , and then press .</p>	
<p>(4) Select Source using  or , and then press .</p> <p><Inputting the parameters></p> <p>Select the parameters using  or , and then press .</p> <p>Alternatively: Select the parameters using the number keys ( to ) , and then press .</p>	<p>Select the sound source <Source>. Depending on the selected sound source, the setting parameters associated with that source will differ.</p>

<Source>

0	OFF	No output.
1	Ext. Optical	The digital input (optical) is output. No parameters are provided. *
2	Ext. COAXIAL	The digital input (coaxial) is output. No parameters are provided. *
3	Ext. Analog to L-PCM	The analog input is converted to L-PCM, and output. For further details, refer to <Ext. Analog to L-PCM setting parameters>.
4	Ext. Analog to DSD	The analog input is converted to DSD, and output. For further details, refer to <Ext. Analog to DSD setting parameters>.
5	Int. L-PCM	Sine waves are output by the internal L-PCM. For further details, refer to <Int. L-PCM setting parameters>.
	Int. Non L-PCM 	The sound of the non L-PCM stored in the internal memory is output. For further details, refer to <Int. Non L-PCM setting parameters>.
	Int. L-PCM(Flash) 	The sound of the L-PCM stored in the internal memory is output. For further details, refer to <Int. L-PCM (Flash) setting parameters>.
	Int. DSD 	The sound of the DSD stored in the internal memory is output. For further details, refer to <Int. DSD setting parameters>.
	Ext. I2S L-PCM 	The non L-PCM input from the I2S connector is output. For further details, refer to <Ext. I2S L-PCM setting parameters>.

Ext. I2S Non L-PCM Option.	The L-PCM input from the I2S connector is output. For further details, refer to <Ext. I2S Non L-PCM setting parameters>.
---	---

* When selecting **Ext.Optical** or **Ext.Coaxial** as the **sound source setting**, select the setting after inputting stable signals. (Check the sampling frequency of the input audio signals only after selecting the setting.)

Described below are the setting parameters associated with each sound source.



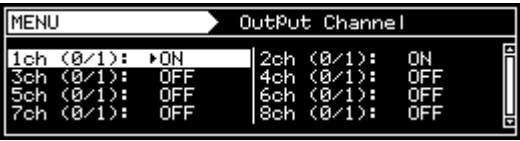

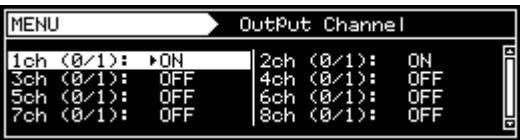

<Ext. Analog to L-PCM setting parameters>

	Setting menu display																						
(1)	Sampling Frequency (0-6)	<p>Set the sampling frequency.</p> <table border="1"> <tr><td>0</td><td>32 KHz</td><td>This is for sampling at a 32 kHz frequency.</td></tr> <tr><td>1</td><td>44.1 KHz</td><td>This is for sampling at a 44.1 kHz frequency.</td></tr> <tr><td>2</td><td>48 KHz</td><td>This is for sampling at a 48 kHz frequency.</td></tr> <tr><td>3</td><td>88.2 KHz</td><td>This is for sampling at a 88.2 kHz frequency.</td></tr> <tr><td>4</td><td>96 KHz</td><td>This is for sampling at a 96 kHz frequency.</td></tr> <tr><td>5</td><td>176.4 KHz</td><td>This is for sampling at a 176.4 kHz frequency.</td></tr> <tr><td>6</td><td>192 KHz</td><td>This is for sampling at a 192 kHz frequency.</td></tr> </table>	0	32 KHz	This is for sampling at a 32 kHz frequency.	1	44.1 KHz	This is for sampling at a 44.1 kHz frequency.	2	48 KHz	This is for sampling at a 48 kHz frequency.	3	88.2 KHz	This is for sampling at a 88.2 kHz frequency.	4	96 KHz	This is for sampling at a 96 kHz frequency.	5	176.4 KHz	This is for sampling at a 176.4 kHz frequency.	6	192 KHz	This is for sampling at a 192 kHz frequency.
0	32 KHz	This is for sampling at a 32 kHz frequency.																					
1	44.1 KHz	This is for sampling at a 44.1 kHz frequency.																					
2	48 KHz	This is for sampling at a 48 kHz frequency.																					
3	88.2 KHz	This is for sampling at a 88.2 kHz frequency.																					
4	96 KHz	This is for sampling at a 96 kHz frequency.																					
5	176.4 KHz	This is for sampling at a 176.4 kHz frequency.																					
6	192 KHz	This is for sampling at a 192 kHz frequency.																					
(2)	Output Channel	<p>Whether to set ON or OFF for channel 1 to 8 of the embedded audio is set here.</p>  <table border="1"> <tr><td>0</td><td>OFF</td><td>No output.</td></tr> <tr><td>1</td><td>ON</td><td>With channels 1, 3, 5 and 7: The left-channel input is output. With channels 2, 4, 6 and 8: The right-channel input is output.</td></tr> </table>	0	OFF	No output.	1	ON	With channels 1, 3, 5 and 7: The left-channel input is output. With channels 2, 4, 6 and 8: The right-channel input is output.															
0	OFF	No output.																					
1	ON	With channels 1, 3, 5 and 7: The left-channel input is output. With channels 2, 4, 6 and 8: The right-channel input is output.																					

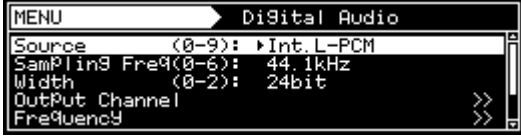
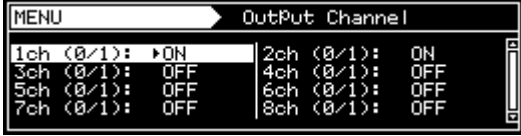
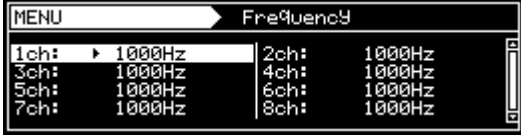
<Ext. Analog to DSD setting parameters>

	Setting menu display							
(1)	Output Channel	<p>Whether to set ON or OFF for channel 1 to 8 of the embedded audio is set here.</p>  <table border="1"> <tr><td>0</td><td>OFF</td><td>No output.</td></tr> <tr><td>1</td><td>ON</td><td>With channels 1, 3, 5 and 7: The left-channel input is output. With channels 2, 4, 6 and 8: The right-channel input is output.</td></tr> </table>	0	OFF	No output.	1	ON	With channels 1, 3, 5 and 7: The left-channel input is output. With channels 2, 4, 6 and 8: The right-channel input is output.
0	OFF	No output.						
1	ON	With channels 1, 3, 5 and 7: The left-channel input is output. With channels 2, 4, 6 and 8: The right-channel input is output.						

<Int. L-PCM setting parameters>

	Setting menu display																						
(1)	Sampling Frequency (0-6)	<p>This sets the sampling frequency.</p> <table border="1"> <tr> <td>0</td> <td>32 KHz</td> <td>This outputs the signals at a 32 kHz sampling frequency.</td> </tr> <tr> <td>1</td> <td>44.1 KHz</td> <td>This outputs the signals at a 44.1 kHz sampling frequency.</td> </tr> <tr> <td>2</td> <td>48 KHz</td> <td>This outputs the signals at a 48 kHz sampling frequency.</td> </tr> <tr> <td>3</td> <td>88.2 KHz</td> <td>This outputs the signals at a 88.2 kHz sampling frequency.</td> </tr> <tr> <td>4</td> <td>96 KHz</td> <td>This outputs the signals at a 96 kHz sampling frequency.</td> </tr> <tr> <td>5</td> <td>176.4 KHz</td> <td>This outputs the signals at a 176.4 kHz sampling frequency.</td> </tr> <tr> <td>6</td> <td>192 KHz</td> <td>This outputs the signals at a 192 kHz sampling frequency.</td> </tr> </table>	0	32 KHz	This outputs the signals at a 32 kHz sampling frequency.	1	44.1 KHz	This outputs the signals at a 44.1 kHz sampling frequency.	2	48 KHz	This outputs the signals at a 48 kHz sampling frequency.	3	88.2 KHz	This outputs the signals at a 88.2 kHz sampling frequency.	4	96 KHz	This outputs the signals at a 96 kHz sampling frequency.	5	176.4 KHz	This outputs the signals at a 176.4 kHz sampling frequency.	6	192 KHz	This outputs the signals at a 192 kHz sampling frequency.
0	32 KHz	This outputs the signals at a 32 kHz sampling frequency.																					
1	44.1 KHz	This outputs the signals at a 44.1 kHz sampling frequency.																					
2	48 KHz	This outputs the signals at a 48 kHz sampling frequency.																					
3	88.2 KHz	This outputs the signals at a 88.2 kHz sampling frequency.																					
4	96 KHz	This outputs the signals at a 96 kHz sampling frequency.																					
5	176.4 KHz	This outputs the signals at a 176.4 kHz sampling frequency.																					
6	192 KHz	This outputs the signals at a 192 kHz sampling frequency.																					
(2)	Width (0-2)	<p>This sets the bit length of the audio data.</p> <table border="1"> <tr> <td>0</td> <td>16 BIT</td> <td>The audio data is output with 16 bits.</td> </tr> <tr> <td>1</td> <td>20 BIT</td> <td>The audio data is output with 20 bits.</td> </tr> <tr> <td>2</td> <td>24 BIT</td> <td>The audio data is output with 24 bits.</td> </tr> </table>	0	16 BIT	The audio data is output with 16 bits.	1	20 BIT	The audio data is output with 20 bits.	2	24 BIT	The audio data is output with 24 bits.												
0	16 BIT	The audio data is output with 16 bits.																					
1	20 BIT	The audio data is output with 20 bits.																					
2	24 BIT	The audio data is output with 24 bits.																					
(3)	Output Channel	<p>Whether to set ON or OFF for channels 1 to 8 of the embedded audio are set here.</p>  <table border="1"> <tr> <td>0</td> <td>OFF</td> <td>No output.</td> </tr> <tr> <td>1</td> <td>ON</td> <td>Output.</td> </tr> </table>	0	OFF	No output.	1	ON	Output.															
0	OFF	No output.																					
1	ON	Output.																					
(4)	Frequency	<p>This sets the frequency (sine wave) of the audio signals to be output.</p>  <table border="1"> <tr> <td>20 - 96000</td> <td>A frequency up to half the value of the sampling frequency can be set. Example: When the sampling frequency is 48 kHz This sets a frequency in the 20 Hz to 24 kHz ranges</td> </tr> </table>	20 - 96000	A frequency up to half the value of the sampling frequency can be set. Example: When the sampling frequency is 48 kHz This sets a frequency in the 20 Hz to 24 kHz ranges																			
20 - 96000	A frequency up to half the value of the sampling frequency can be set. Example: When the sampling frequency is 48 kHz This sets a frequency in the 20 Hz to 24 kHz ranges																						
(5)	Level InpMode	<p>This sets the level input method.</p> <table border="1"> <tr> <td>0</td> <td>dB (1-8ch All)</td> <td> <p>This sets all the channels 1 to 8 as a dB display. Setting range: -138.48 to 0.00 [dB]</p>  </td> </tr> <tr> <td>1</td> <td>BIT (1-8ch All)</td> <td> <p>This sets all the channels 1 to 8 as a bit display. Setting range: 0 to 7FFFFFFh</p>  </td> </tr> </table>	0	dB (1-8ch All)	<p>This sets all the channels 1 to 8 as a dB display. Setting range: -138.48 to 0.00 [dB]</p> 	1	BIT (1-8ch All)	<p>This sets all the channels 1 to 8 as a bit display. Setting range: 0 to 7FFFFFFh</p> 															
0	dB (1-8ch All)	<p>This sets all the channels 1 to 8 as a dB display. Setting range: -138.48 to 0.00 [dB]</p> 																					
1	BIT (1-8ch All)	<p>This sets all the channels 1 to 8 as a bit display. Setting range: 0 to 7FFFFFFh</p> 																					

	2	db (1-8ch Separate)	<p>This sets channels 1 to 8 separately as a dB display. Setting range: -138.48 to 0.00 [dB]</p> <p>Select the level here.</p>
	3	bit (1-8ch Separate)	<p>This sets channels 1 to 8 separately as a bit display. Setting range: 0 to 7FFFFFFh</p> <p>Select the level here.</p>

<Int. Non L-PCM setting parameters> (Option)

	Setting menu display	
(1)	Flash Data No.	<p>Set the audio data here. Setting range: 1 to 99 Set the registered audio data. * For further details on registering the audio data, refer to “4.16.3 Flash data entry (option).”</p>

<Int.L-PCM(Flash) setting parameters> (Option)

	Setting menu display	
(1)	Flash Data No.	<p>Set the audio data here. Setting range: 1 to 99 Set the registered audio data. * For further details on registering the audio data, refer to “4.16.3 Flash data entry (option).”</p>

<Int. DSD setting parameters> (Option)

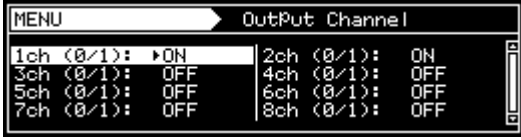
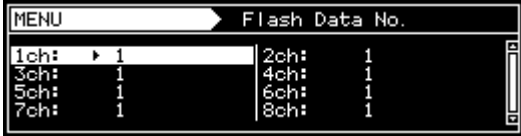
	Setting menu display							
(1)	Output Channel	<p>This sets ON or OFF for channels 1 to 8 of the embedded audio.</p>  <table border="1"> <tr> <td>0</td> <td>OFF</td> <td>No output.</td> </tr> <tr> <td>1</td> <td>ON</td> <td>Output.</td> </tr> </table>	0	OFF	No output.	1	ON	Output.
0	OFF	No output.						
1	ON	Output.						
(2)	Flash Data No.	<p>Set the audio data to be output in each channel. Setting range: 1 to 99</p>  <p>Register audio data is set here. * For further details on registering the audio data, refer to "4.16.3 Flash data entry (option)."</p>						

<Ext. I2S L-PCM setting parameters> (Option)

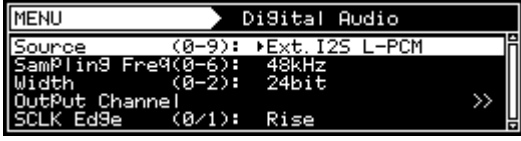
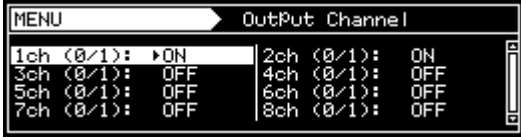
	Setting menu display																						
(1)	Sampling Frequency (0-6)	<p>Set the sampling frequency of the audio signals which are input here.</p> <table border="1"> <tr> <td>0</td> <td>32 KHz</td> <td>The signals are input/output with a 32 kHz sampling frequency.</td> </tr> <tr> <td>1</td> <td>44.1 KHz</td> <td>The signals are input/output with a 44.1 kHz sampling frequency.</td> </tr> <tr> <td>2</td> <td>48 KHz</td> <td>The signals are input/output with a 48 kHz sampling frequency.</td> </tr> <tr> <td>3</td> <td>88.2 KHz</td> <td>The signals are input/output with a 88.2 kHz sampling frequency.</td> </tr> <tr> <td>4</td> <td>96 KHz</td> <td>The signals are input/output with a 96 kHz sampling frequency.</td> </tr> <tr> <td>5</td> <td>176.4 KHz</td> <td>The signals are input/output with a 176.4 kHz sampling frequency.</td> </tr> <tr> <td>6</td> <td>192 KHz</td> <td>The signals are input/output with a 192 kHz sampling frequency.</td> </tr> </table>	0	32 KHz	The signals are input/output with a 32 kHz sampling frequency.	1	44.1 KHz	The signals are input/output with a 44.1 kHz sampling frequency.	2	48 KHz	The signals are input/output with a 48 kHz sampling frequency.	3	88.2 KHz	The signals are input/output with a 88.2 kHz sampling frequency.	4	96 KHz	The signals are input/output with a 96 kHz sampling frequency.	5	176.4 KHz	The signals are input/output with a 176.4 kHz sampling frequency.	6	192 KHz	The signals are input/output with a 192 kHz sampling frequency.
0	32 KHz	The signals are input/output with a 32 kHz sampling frequency.																					
1	44.1 KHz	The signals are input/output with a 44.1 kHz sampling frequency.																					
2	48 KHz	The signals are input/output with a 48 kHz sampling frequency.																					
3	88.2 KHz	The signals are input/output with a 88.2 kHz sampling frequency.																					
4	96 KHz	The signals are input/output with a 96 kHz sampling frequency.																					
5	176.4 KHz	The signals are input/output with a 176.4 kHz sampling frequency.																					
6	192 KHz	The signals are input/output with a 192 kHz sampling frequency.																					
(2)	Width (0-2)	<p>This sets the bit length of the input audio data. (Only the channel status bits are set.)</p> <table border="1"> <tr> <td>0</td> <td>16 BIT</td> <td>The data is input/output as 16 bits.</td> </tr> <tr> <td>1</td> <td>20 BIT</td> <td>The data is input/output as 20 bits.</td> </tr> <tr> <td>2</td> <td>24 BIT</td> <td>The data is input/output as 24 bits.</td> </tr> </table>	0	16 BIT	The data is input/output as 16 bits.	1	20 BIT	The data is input/output as 20 bits.	2	24 BIT	The data is input/output as 24 bits.												
0	16 BIT	The data is input/output as 16 bits.																					
1	20 BIT	The data is input/output as 20 bits.																					
2	24 BIT	The data is input/output as 24 bits.																					
(3)	Output Channel	<p>Set ON/OFF of CH1 to 8 of the input audio data.</p>  <table border="1"> <tr> <td>0</td> <td>OFF</td> <td>The data is not input/output.</td> </tr> </table>	0	OFF	The data is not input/output.																		
0	OFF	The data is not input/output.																					

		1	ON	The data is input/output.
(4)	SCLK Edge (0/1)	The SCLK edge to be used when the I2S data is input is set here.		
		0	Rise	The data is captured at the SCLK rising edge.
		1	Fall	The data is captured at the SCLK falling edge.

<Ext. I2S Non L-PCM setting parameters> (Option)

	Setting menu display			
(1)	Sampling Frequency (0-A)	The sampling frequency of the input audio signals is set here.		
		0	32 KHz	The signals are input/output with a 32 kHz sampling frequency.
		1	44.1 KHz	The signals are input/output with a 44.1 kHz sampling frequency.
		2	48 KHz	The signals are input/output with a 48 kHz sampling frequency.
		3	88.2 KHz	The signals are input/output with a 88.2 kHz sampling frequency.
		4	96 KHz	The signals are input/output with a 96 kHz sampling frequency.
		5	176.4 KHz	The signals are input/output with a 176.4 kHz sampling frequency.
		6	192 KHz	The signals are input/output with a 192 kHz sampling frequency.
		7	352.8 KHz	The signals are input/output with a 352.8 kHz sampling frequency.
		8	384 KHz	The signals are input/output with a 384 kHz sampling frequency.
		9	705.6 KHz	The signals are input/output with a 705.6 kHz sampling frequency.
	A	768 KHz	The signals are input/output with a 768 kHz sampling frequency.	
(2)	SCLK Edge (0/1)	The SCLK edge to be used when the I2S data is input is set here.		
		0	Rise	The data is captured at the SCLK rising edge.
		1	Fall	The data is captured at the SCLK falling edge.

















4.16.2 Audio sweep settings

When **Internal PCM** is selected by the **Digital Audio > Source** setting, the audio sweep function is available, and the audio output frequency is incremented at the specified interval.

For further details on the audio sweep settings, refer to “4.1.9 Audio sweep settings.”

4.16.3 Flash data entry (option)

Audio data (VT-8500-0006/0008, etc.) can be stored in the VG-870B/871B/873/874.

(1)	Preparations <u>Store audio data on a CF card, and insert the card into the slot on the front panel of the VG-870B/871B/873/874.</u>	* Audio data and a sample program are saved in the VT-8500-0006/0008 (CD). For further details on audio data storing procedures, refer to the VT-8500-0006/0008 (CD) instruction manual.
(2)	Select Audio Flash Data Entry using   or   , and then press  .	
(3)	Select the parameters using  or   , and then press  .	 Specify the number of the audio data group to be stored.
(4)	Select EXECUTE using  or   , and then press  to store the data.	 <p>Note: Do not eject the CF card or turn off the power of the VG-870B/871B/873/874 until “Complete” appears on the screen.</p>

* Groups of audio data up to 64MB created by SP-8870 software can be saved in the VG-870B/871B/873/874.

4.17 Audio sweep setting

For details on the audio sweep settings, refer to “4.1.9 Audio sweep settings.”

5

FUNCTIONS AVAILABLE WITH TV STANDARD SIGNALS

Text, data, copy prevention information and other data are superimposed in the vertical blanking interval (VBI) of the NTSC, PAL and SECAM TV standard signals, and transmitted as multiplexed broadcasts.

The VG-870B/871B/873/874 supports the following functions.

- (1) Macrovision (Option)
- (2) Closed caption/V-Chip
- (3) Teletext
- (4) WSS
- (5) CGMS-A/ID-1

The TV standard signals and functions supported are summarized in the table below.

	Macrovision	Closed caption V-chip	Teletext	WSS	CGMS-A ID-1
NTSC-J	○	○	-	-	○
NTSC-M	○	○	-	-	○
NTSC-443	○	○	-	-	○
PAL-M	○	○	-	-	○
PAL-60	○	○	-	-	○
PAL(-BDGHIK)	○	○	○	○	-
PAL-N	○	○	-	○	-
PAL-Nc	○	○	-	○	-
SECAM	○	-	-	○	-

CAUTION

- The Macrovision, Closed caption (V-Chip) and Teletext functions cannot be executed at the same time.

5.1 Macrovision

5.1.1 Description and specifications

■ What is “Macrovision”?

Macrovision is a copy prevention system developed by Macrovision Corporation.

Widely used by video sources such as VHS and DVD-Video on the market and by satellite broadcasts, for instance, the system ensures that, by causing the automatic gain control (AGC) of the video decks to malfunction, users will not be able to record properly the video output sources which are protected by the system.

The AGC circuit is designed to adjust the gain of the input signals automatically and maintain the appropriate sensitivity, and almost all consumer-use VTRs now feature it. It serves to make dark images a little brighter and excessively light images darker and keep them this way.

While keeping the luminance and chrominance signal components of the video signals unchanged, Macrovision's copy prevention signals cause the AGC to malfunction by mixing signals with non-standard levels in the vertical blanking interval. This is why the brightness of the images will fluctuate even when the images are recorded. These signals also have the effect of causing trouble for the sync signals and disturbances in the images.

The trouble caused ensures that content is unwatchable even when it has been copied.

■ What does the “color stripe” function do?

This function is part of the Macrovision standard, and it provides color stripes to overlap with the regular Macrovision signals.

It constitutes a method of superimposing the modulated color burst signal onto the video signals, and it is also referred to as a means of color burst copy prevention.

The color stripe function inserts thin horizontal lines into the copied images and, like the Macrovision system, it makes the images unwatchable.

* The color stripes are provided only in the Type 2 and 3 modes of the NTSC-M and J systems.

■ Macrovision specifications

Macrovision supports the TV signals of the following systems.





















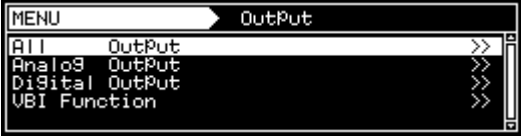







Its signals are superimposed onto the composite signals and Y/C signals.

- NTSC-M, NTSC-J, NTSC-443
- PAL-60, PAL, PAL-M, PAL-N, PAL-Nc
- SECAM

CAUTION

- Macrovision is an option. Contact ASTRODESIGN sales representative or your dealer.
- The Macrovision signals have different effects depending on the type of VHS or DVD player. When using the system, please check the terms and conditions of the agreement with Macrovision Corporation.

5.1.2 Setting procedure

<p>(1) Select Program Edit using  →  or  INC  DEC, and then press  ..</p>	 <pre> MENU Program Edit Program Name : ▶NTSC-M Timing < TIM > >>> Output < TIM > >>> Audio < TIM > >>> Pattern < PAT > >>> </pre>																																										
<p>(2) Select Output using  or  INC  DEC, and then press .</p>	 <pre> MENU OutPut All OutPut >>> Analog OutPut >>> Digital OutPut >>> VBI Function >>> </pre>																																										
<p>(3) Select VBI Function using  or  INC  DEC, and then press .</p>	 <pre> MENU VBI Function Macrovision >>> Closed Caption >>> U-ChIP >>> Teletext >>> WSS >>> </pre>																																										
<p>(4) Select Macrovision using  or  INC  DEC, and then press .</p>	 <pre> MENU Macrovision Mode <0-5>: OFF </pre>																																										
<p>(5) Select Mode using  or  INC  DEC, and then press .</p> <p>Alternatively: Make the selections using the number keys  to , and then press .</p>	<p>The selection options for Mode differ depending on the TV signals. (OFF is set for any timing format not listed below.)</p> <table border="1"> <tr><th colspan="2">NTSC-M</th></tr> <tr><td>0</td><td>OFF</td></tr> <tr><td>1</td><td>Type1 (AGC only)</td></tr> <tr><td>2</td><td>Type2 (AGC + 2Line Colorstripe)</td></tr> <tr><td>3</td><td>Type3 (AGC + 4Line Colorstripe)</td></tr> <tr><td>4</td><td>VHS USA</td></tr> <tr><td>5</td><td>VHS US obs.</td></tr> <tr><th colspan="2">NTSC-J</th></tr> <tr><td>0</td><td>OFF</td></tr> <tr><td>1</td><td>Type1 (AGC only)</td></tr> <tr><td>2</td><td>Type2 (AGC + 2Line Colorstripe)</td></tr> <tr><td>3</td><td>Type3 (AGC + 4Line Colorstripe)</td></tr> <tr><td>4</td><td>VHS Japan1</td></tr> <tr><td>5</td><td>VHS Japan2</td></tr> <tr><th colspan="2">NTSC-443, PAL-60, PAL-M</th></tr> <tr><td>0</td><td>OFF</td></tr> <tr><td>1</td><td>Type1,2,3 (AGC only)</td></tr> <tr><th colspan="2">PAL, PAL-N, PAL-Nc, SECAM</th></tr> <tr><td>0</td><td>OFF</td></tr> <tr><td>1</td><td>Type1,2,3 (AGC only)</td></tr> <tr><td>2</td><td>VHS</td></tr> </table>	NTSC-M		0	OFF	1	Type1 (AGC only)	2	Type2 (AGC + 2Line Colorstripe)	3	Type3 (AGC + 4Line Colorstripe)	4	VHS USA	5	VHS US obs.	NTSC-J		0	OFF	1	Type1 (AGC only)	2	Type2 (AGC + 2Line Colorstripe)	3	Type3 (AGC + 4Line Colorstripe)	4	VHS Japan1	5	VHS Japan2	NTSC-443, PAL-60, PAL-M		0	OFF	1	Type1,2,3 (AGC only)	PAL, PAL-N, PAL-Nc, SECAM		0	OFF	1	Type1,2,3 (AGC only)	2	VHS
NTSC-M																																											
0	OFF																																										
1	Type1 (AGC only)																																										
2	Type2 (AGC + 2Line Colorstripe)																																										
3	Type3 (AGC + 4Line Colorstripe)																																										
4	VHS USA																																										
5	VHS US obs.																																										
NTSC-J																																											
0	OFF																																										
1	Type1 (AGC only)																																										
2	Type2 (AGC + 2Line Colorstripe)																																										
3	Type3 (AGC + 4Line Colorstripe)																																										
4	VHS Japan1																																										
5	VHS Japan2																																										
NTSC-443, PAL-60, PAL-M																																											
0	OFF																																										
1	Type1,2,3 (AGC only)																																										
PAL, PAL-N, PAL-Nc, SECAM																																											
0	OFF																																										
1	Type1,2,3 (AGC only)																																										
2	VHS																																										
<p></p>	<p>Display returns to the initial screen.</p>																																										

5.2 Closed captions/V-Chip

5.2.1 Description and specifications

■ What does the closed caption (CC) function do?

Closed captioning was developed in the United States, and it provides broadcasts with subtitles for the hearing impaired so that people who are deaf or hard of hearing can enjoy movies and news programs.

The captions are “closed” in the sense that they are not displayed on the screen during normal playback. Conversely, the Japanese-language subtitles and other such characters used with video content which are “burned into” the images from the start are referred to as “open captions.”

Although closed captioning was originally developed as a technology for the hearing impaired, it is currently attracting the attention of educators and language learners as a tool which helps develop “listening.”

The CC subtitle data is superimposed onto line 21 (first field) and line 284 (second field) of the NTSC output signals, and output. The subtitle data has two modes, captions and text. Another available service is the Extended Data Service (EDS) which transmits titles, ratings and other program information using line 284 (second field). The V-Chip described below uses the EDS function.

A total of 32 characters can be displayed per line by CC. There are 15 lines, but the maximum number of lines is limited to 4 in the caption mode (CC1 to 4). All 15 lines can be displayed in the text mode (T1 to 4).

■ What does the V-Chip do?

The V-Chip refers to a semiconductor chip that blocks out TV programs containing violence, bad language and sex situations. “V” refers to violence, and the viewing of programs is blocked out according to the ratings which are categorized by the extremity of the program content. Once the ratings are set in a receiver (TV set) which incorporates the V-Chip function, the rating information of EDS is decoded, and whether the programs is to be output to the screen is automatically determined.

■ Specifications of closed caption/V-Chip

Closed caption/V-Chip supports the TV signals of the following systems.

Closed caption/V-Chip is superimposed onto the composite signals and Y/C signals.

- NTSC-M, NTSC-J, NTSC-443
- PAL-60, PAL, PAL-M, PAL-N, PAL-Nc





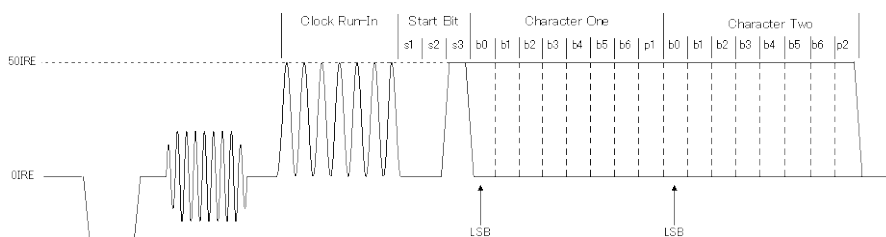























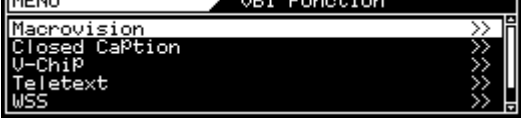





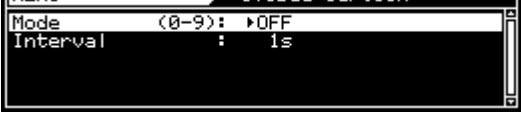





Note) When using VM-1812, if 625-line timing (PAL, PAL-N, PAL-Nc) is output, the caption data is superimposed on the 23th line (335-line). In case of using VM-1812-B, it is imposed on 21st line (334 line).

The closed caption/V-Chip waveform is shown below. Following the color burst come a sine wave known as Clock Run-In and continues to the start bit. The start bit is always “001.” Two bytes of data (Char1, Char2) are sent for each line. Char1 and Char2 are decoded from LSB, and an odd parity is usually added to MSB (bit 8).



Closed Caption / V-Chip (21Line System)

5.2.2 Closed caption settings

(1)	<p>Select Program Edit using   </p> <p>or  , and then press .</p>	 <pre> MENU Program Edit Program Name : ▶NTSC-M Timing (TIM) >>> Output (TIM) >>> Audio (TIM) >>> Pattern (PAT) >>> </pre>
(2)	<p>Select Output using  </p> <p>or  ,</p> <p>and then press .</p>	 <pre> MENU OutPut All OutPut >>> Analog OutPut >>> Digital OutPut >>> VBI Function >>> </pre>
(3)	<p>Select VBI Function using  </p> <p>or </p> <p>, and then press .</p>	 <pre> MENU VBI Function Macrovision >>> Closed Caption >>> U-Chip >>> Teletext >>> WSS >>> </pre>
(4)	<p>Select Closed Caption using  </p> <p>or </p> <p>, and then press .</p>	 <pre> MENU Closed Caption Mode (0-9): ▶OFF Interval : 1s </pre>
(5)	<p><Selecting the setting items from the table></p> <p>Select the parameters using   </p> <p>or  , and then press .</p>	<p>For details on the setting items and parameters, refer to <Table of closed caption setting items> provided below.</p>
(6)	<p><Setting the parameters></p> <p>Select the parameters using  </p> <p>or </p> <p>, and then press .</p> <p>Alternatively:</p> <p>Select the parameters using the number keys</p> <p>( to ), and then press .</p>	
	<p>Upon completion of the settings:</p> <p>Press .</p>	<p>Display returns to the initial screen.</p>

<Table of closed caption setting items>

(1)	Mode (0-9)	The mode is set here.		
		0	OFF	The captions are set to OFF.
		1	CC1	Closed caption mode 1 is selected here.
		2	CC2	Closed caption mode 2 is selected here.
		3	CC3	Closed caption mode 3 is selected here.
		4	CC4	Closed caption mode 4 is selected here.
		5	T1	Text data mode 1 is selected here.
		6	T2	Text data mode 2 is selected here.
		7	T3	Text data mode 3 is selected here.
		8	T4	Text data mode 4 is selected here.
	9	USER Data	The user data is selected here. Up to 20 user data can be registered using SP-8870.	
(2)	Interval	0 to 60	Interval	The interval at which the closed caption data is transmitted is set. (in 1-second increments)
(3)	USER Data No.	1 to 20		The user data number is set. This is valid when USER Data has been selected as the Mode setting in (1).

Listed below are the types of closed caption services available.

- CC1** - Primary Synchronous Caption Service
(caption service for primary language)
- CC2** - Special Non-Synchronous Use Caption
(service which does not need to be synchronized with the sound, etc.)
- CC3** - Secondary Synchronous Caption Service
(caption service for secondary language)
- CC4** - Special Non-Synchronous Use Caption
(service which does not need to be synchronized with the sound, etc.)
- T1** - First Text service (text service)
- T2** - Second Text service (text service)
- T3** - Third Text service (text service)
- T4** - Fourth Text service (text service)

■ The content of Closed caption internal data (1/3)

Service	Caption style, Line, Color, Option setting, etc	Character
CC1 - CC4	Roll-up2 ROW2 Background: black, transparence Text: white	Primary Synchronous Caption Service -- CC1 (CC1) Secondary Synchronous Caption Service -- CC2 (CC2) Special Non-Synchronous Use Captions -- CC3 (CC3) Special Non-Synchronous Use Captions -- CC4 (CC4)
	Roll-up3 ROW10 Background: blue, transparence Text: yellow	Roll-up Style characters are always displayed immediately. Each time a Carriage Return is received, the text is scrolled up one row.
	Roll-up4 ROW15, indent Background: cyan, transparence Text: Red	Standard characters 0123456789 ABCDEFGHIJ áâçèéëíîñóôúú !.,:;7"#% &@/() []+-÷<=>? Music note, solid block, Transparent space, solid block, Music note, solid block, Transparent space
	Pop-on ROW1 ROW2 ROW3 Background: red, half transparence Text: cyan	Pop-on Style Caption data are loaded into a non-displayed memory.
	Pop-on ROW4 ROW5 ROW6 Background: green, half transparence Text: blue, flash	End of Caption command (EOC) "flips" displayed and non displayed memory.
	Pop-on ROW7 indent ROW8 indent ROW9 indent Background: magenta, non transparence Text: green, italic	ABCDEFGHIJ 0123456789 À á Ø ø □ ⊔











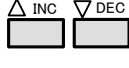



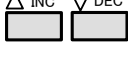





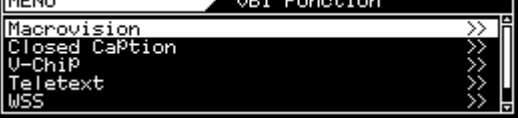

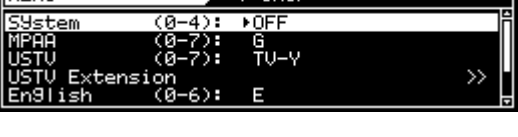

■ The content of Closed caption internal data (2/3)

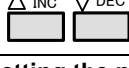
Service	Caption style, Line, Color, Option setting, etc	Character
CC1 - CC4	Pop-on ROW12 indent ROW13 indent ROW14 indent ROW15 indent Background: white, non transparence Test: red, underline	ÁÉÓÚÛü, opening single quote, inverted exclamation mark ÀÂÇÈËËëÏïÔÙù«» ÃäİıİòÕõ{} \^_~ ÄäÖößƒ
	Paint-on ROW1 ROW3 ROW4 ROW6 ROW7 ROW9 Background: yellow, half transparence Text: blue	Paint-on Style Characters are always displayed immediately. Characters on next row will be erased by Backspase. ABCDEFGH (A to H is deleted by Backspase)
	Paint-on ROW5 ROW6 ROW7 ROW8 ROW9 ROW10 ROW12, indent ROW14, indent Background: yellow, half transparence Text: blue	Once the cursor reaches the 32nd column position on any row, all subsequent characters will be displayed In that column replacing any previous character. ABCDEFGHIJKLMNPNOPQRSTUVWXYZ (S to Y are replaced by Z) Abcdefghijklmnopqrstuvwxyz (n to y are replaced by z)
T1	--	First Text Service -- T1 Text Mode is a data service, generally not program related, which may be transmitted using either field of line21. Text Mode data are always displayed as soon as they are received and are intended to be displayed in a manner which isolates them from the video program used to transmit the data. Once the display window is filled these data are always scrolled upward through the display window provided by the decoder.
T2	--	Second Text Service -- T2 ABCDEFGHIJKLMNPNOPQRSTUVWXYZ abcdefghijklmnopqrstuvwxyz 012345678901234567890 !#\$%&'()á+,-./ :;<=>@[é]íóú *._© SM • ¥

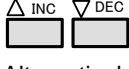
■ The contents of Closed caption internal data (3/3)

Service	Caption style, Line, Color, Option setting, etc	Character
T3	--	<p>Third Text Service -- T3</p> <p>A Text Mode may be used that consists of data formatted to fill a box which in height is not less than 7 rows and not more than 15 rows (all of which should be contiguous), and in width is not less than 32 columns. Text should be displayed over a solid background to isolate it from the unrelated program video. Each row of text contains maximum of 32 characters.</p>
T4	--	<p>Fourth Text Service -- T4</p> <p>ABCDEFGHIJKLMNOPQRSTUVWXYZ abcdefghijklmnopqrstuvwxyz 012345678901234567890 ! " # \$ % & ' () * + , - . / : ; < = > ? @ [é] í ó ú * . - ©SM • ♣</p>

5.2.3 V-Chip settings

(1)	<p>Select Program Edit using  or , and then press .</p>	 <pre> MENU Program Edit Program Name : ▶NTSC-M Timing (TIM) >>> Output (TIM) >>> Audio (TIM) >>> Pattern (PAT) >>> </pre>
(2)	<p>Select Output using  or , and then press .</p>	 <pre> MENU OutPut All OutPut >> Analog OutPut >>> Digital OutPut >>> VBI Function >>> </pre>
(3)	<p>Select VBI Function using  or , and then press .</p>	 <pre> MENU VBI Function Macrovision >>> Closed Caption >>> U-Chip >>> Teletext >>> WSS >>> </pre>
(4)	<p>Select V-chip using  or , and then press .</p>	 <pre> MENU V-Chip System (0-4): ▶OFF MPAA (0-7): G USTV (0-7): TU-Y USTV Extension >> English (0-6): E </pre>
(5)	<p><Selecting the setting items from the table> Select the parameters using  or , and then press .</p>	<p>For further details on the setting items and parameters, refer to <Table of V-Chip setting items> below.</p>
(6)	<p><Setting the parameters> Set the numerical values using  or , and then press .</p> <p>Alternatively: Make the selections using the number keys 0/STATUS ( to ), and then press .</p>	
	<p>Upon completion of the settings: Press .</p>	<p>Display returns to the initial screen.</p>

<Table of V-Chip setting items>

(1)	System (0-4)	The rating system is selected here.		
		0	OFF	The V-Chip is set to OFF here.
		1	MPAA	MPAA is set here.
		2	U.S.TV	U.S.TV is set here.
		3	English	Canadian English is set here.
	4	French	Canadian French is set here.	

The names of the rating systems and a brief description of each are presented below.

MPAA: Motion Picture Association of America

This organization was set up in order to promote the spread of American movies. It is active in many fields such as promoting exports overseas and cracking down on pirated movies. On the U.S. domestic front, it helps viewers exercise voluntary controls by establishing a rating system for violence, sexual content and discriminatory content, for example. Its rating standards are strict and its screening targets images and language that would hardly raise an eyebrow in Japan.

U.S.TV: U.S. TV Parental Guideline Rating System

This rating system is incorporated in ordinary TV sets installed in American homes.

English: Canadian English Language Rating System

This rating system targets Canadian English.

French: Canadian French Language Rating System

This rating system targets Canadian French.

(2)	MPAA	These ratings which apply when MPAA has been selected as the System setting in (1) above are set here.		
		0	G	"General Audience" is set as the MPAA rating.
		1	PG	"Parental Guidance" is set as the MPAA rating.
		2	PG-13	"Parents Strongly Cautioned" is set as the MPAA rating.
		3	R	"Restricted" is set as the MPAA rating.
		4	NC-17	"No One 17 and Under Admitted" is set as the MPAA rating.
		5	X	"Adult Movie" is set as the MPAA rating.
		6	Not Rated	"Not Submitted For MPAA Review" is set as the MPAA rating.
		7	N/A	"N/A" is set as the MPAA rating.

The names and descriptions of the MPAA ratings are presented below.

G: General Audience

For general audience.

PG: Parental Guidance

Contains scenes unsuitable for young children.

PG-13: Parents Strongly Cautioned

Contains scenes unsuitable for children aged 13 and under.

R: Restricted

Permission of a parent or guardian required for children up to 17 years of age.

NC-17: No One 17 and Under Admitted

Cannot be viewed by anyone aged 17 years and under.

X: Adult Movie

For adults only.

Not Rated

Not Submitted For MPAA Review

N/A

No applicable restrictions

(3)	U.S.TV	These ratings which apply when U.S.TV has been selected as the System setting in (1) above are set here.		
		0	TV-Y	"All children" is set as the U.S.TV rating.
		1	TV-Y7	"Directed to older children" is set as the U.S.TV rating.
		2	TV-G	"General Audience" is set as the U.S.TV rating.
		3	TV-PG	"Parental Guidance Suggested" is set as the U.S.TV rating.
		4	TV-14	"Parents Strongly Cautioned" is set as the U.S.TV rating.
		5	TV-MA	"Mature Audience Only" is set as the U.S.TV rating.
		6	Not Rated 1	"Not Rated" is set as the U.S.TV rating. (Code = 000)
7	Not Rated 2	"Not Rated" is set as the U.S.TV rating. (Code = 111)		
(4)	USTV Extension	The extension bits for U.S. TV are set. The bits which can be set differ depending on the U.S. TV ratings. For further details, refer to " U.S. TV rating system extension bit settings. "		

The names of the U.S. TV ratings and a description of each are presented below.

TV-Y: All children

Suitable for all children.

TV-Y7: Directed to older children

Suitable for children aged 7 and above.

TV-G: General Audience

Suitable for audiences of all ages (must not contain violent scenes, objectionable language or sexual content).

TV-PG: Parental Guidance Suggested

Contains scenes involving some violence and sexual content unsuitable for young children or situations that may induce foul language or incite delinquency.

TV-14: Parents Strongly Cautioned

Contains scenes involving violence and sexual content unsuitable for children aged 14 or below or situations that may induce foul language or incite delinquency.

TV-MA: Mature Audience Only

For adults only; programs with this rating are hardly ever broadcast.

Not Rated1/2

No applicable restrictions

[U.S. TV rating system extension bit settings]

	FV	V	S	L	D
TV-Y	Cannot be set.				
TV-Y7	0: - / 1: *	Cannot be set.			
TV-G	Cannot be set.				
TV-PG	Cannot be set.	0: - / 1: *	0: - / 1: *	0: - / 1: *	0: - / 1: *
TV-14	Cannot be set.	0: - / 1: *	0: - / 1: *	0: - / 1: *	0: - / 1: *
TV-MA	Cannot be set.	0: - / 1: *	0: - / 1: *	0: - / 1: *	Cannot be set.
Not Rated 1	Cannot be set.				
Not Rated 2	Cannot be set.				

* "-" denotes OFF, and "*" ON.

The names of the U.S. TV rating extension service ratings and a description of each are presented below.

FV: Fantasy Violence

Acts of fantasy violence = violence in animated features and comics.

V: Violence

Violence

S: Sexual Situations

Sexual content

L: Adult Language

Foul language

D: Sexually Suggestive Dialog

Sexually suggestive dialog

(5)	English	These ratings which apply when English has been selected as the System setting in (1) above are set here.		
		0	E	“Exempt” is set as the English rating.
		1	C	“Children” is set as the English rating.
		2	C8+	“Children eight years and older” is set as the English rating.
		3	G	“General Programming, suitable for all audiences” is set as the English rating.
		4	PG	“Parental Guidance” is set as the English rating.
		5	14+	“Viewers 14 years and older” is set as the English rating.
		6	18+	“Adult Programming” is set as the English rating.

The names of the Canadian English ratings and a description of each are presented below.

E: Exempt

No age restrictions apply.

C: Children

Programming may be viewed by all children.

C8+: Children eight years and older

Programming may be viewed by children aged 8 and above.

G: General Programming, suitable for all audiences

General programming

PG: Parental Guidance

Permission of a parent required to view programming.

14+: Viewers 14 years and older

Programming may be viewed by children 14 years and older.

18+: Adult Programming

Programming for adults only.

(6)	French	These ratings which apply when French has been selected as the System setting in (1) above are set here.		
		0	E	“Exempt” is set as the French rating.
		1	G	“General” is set as the French rating.
		2	8ans+	“Not recommended for young children” is set as the French rating.
		3	13ans+	“Programming may not be suitable for children under 13” is set as the French rating.
		4	16ans+	“Programming is not suitable for children under 16” is set as the French rating.
		5	18ans+	“Programming restricted to adults” is set as the French rating.

The names of the Canadian French ratings and a description of each are presented below.

E : Exempt

No age restrictions apply.

G : General

General programming.

8ans+ : Not recommended for young children

Programming unsuitable for young children

13ans+ : Programming may not be suitable for children under 13

Programming unsuitable for children aged 13 and under

16ans+ : Programming is not suitable for children under 16

Programming unsuitable for children aged 16 and under













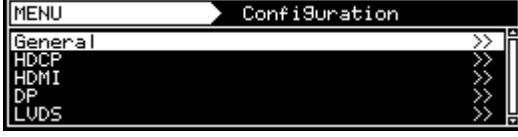

18ans+ : Programming restricted to adults

Programming for adults only.

(7)	Interval	0 to 60	Interval	The interval at which the V-chip data is transmitted is set. (in 1-second increments)
-----	-----------------	---------	-----------------	---

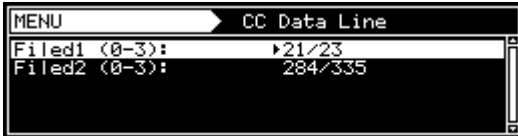
5.2.4 Changing the data superimposing line

It is possible to change the line where the closed captions or V-chip data is to be superimposed.

(1)	Select Configuration using  or  , and then press  .	
(2)	Select VBI Function using  or  , and then press  .	
(3)	Select CC Data Line using  or  , and then press  .	
(4)	Select Field1 or Field2 using  or  , and then press  .	Select the line where the data is to be superimposed. For details, refer to the tables below.

<525 line system timing (NTSC-M, NTSC-J, NTSC-443, PAL-60 and PAL-M)>

	Field1	Field2
0	19 lines	282 lines
1	20 lines	283 lines
2	21 lines	284 lines
3	22 lines	285 lines

<625 line system timing (PAL, PAL-N and PAL-Nc)>

	Field1	Field2
0	21 lines	333 lines
1	22 lines	334 lines
2	23 lines	335 lines
3	24 lines	336 lines



- Lines cannot be set separately for each program.
- It is possible to change the line while closed captions or V-chip data is being executed, but it takes time for the setting to be reflected in the output.
- VM-1812-B can not use this function.

5.3 Teletext

5.3.1 Description and specifications

■ What is “Teletext”?

Teletext is the name of a system used to send still picture program data of text and graphics after multiplexing it in the vertical sync blanking interval of the TV signals. Programs broadcast in Teletext include subtitled broadcasts, news broadcasts, weather forecasts and stock market information. Teletext has achieved a high penetration rate in various countries in Europe and Southeast Asia where the 625/50i system is used.

With Teletext, a total of 40 characters × 25 lines can be contained on a page (per screen), and between 100 and 899 pages of information can be displayed.

■ Teletext specifications

Teletext supports the following TV signals.

Teletext is superimposed onto the composite signals and Y/C signals.

- PAL (but PAL-60, PAL-N and PAL-Nc are not included.)

The vertical sync blanking interval (VBI) and Teletext waveforms are shown below.

The Teletext data can be output in lines 8 to 22 (first field) and lines 321 to 335 (second field) in the vertical sync blanking interval of the PAL signals.

A total of 45 bytes consisting of the Clock Run-In, Framing Code and data bytes (42 bytes) are superimposed in one line.

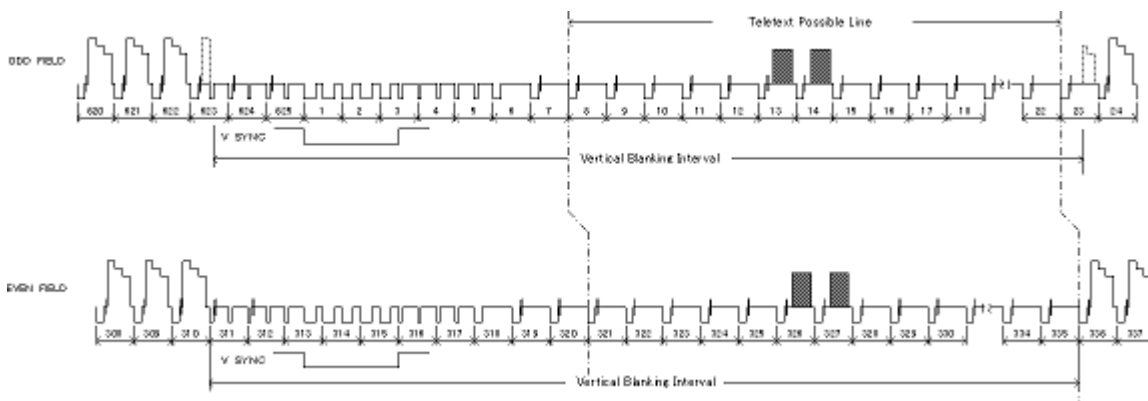



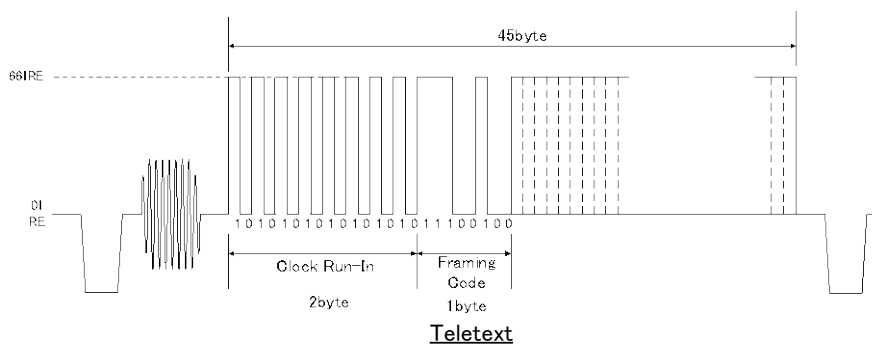



























VBI waveforms



Teletext waveforms







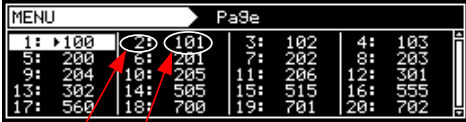

5.3.2 Setting procedure

(1)	<p>Select Program Edit using  or  , and then press .</p>	 <pre> MENU Program Edit Program Name : PAL 4:3 Timing (TIM) >>> Output (TIM) >>> Audio (TIM) >>> Pattern (PAT) >>> </pre>
(2)	<p>Select Output using  or  , and then press .</p>	 <pre> MENU OutPut All OutPut >>> Analog OutPut >>> Digital OutPut >>> VBI Function >>> </pre>
(3)	<p>Select VBI Function using  or , and then press .</p>	 <pre> MENU VBI Function Macrovision >>> Closed Caption >>> U-Chip >>> Teletext >>> WSS >>> </pre>
(4)	<p>Select Teletext using  or  , and then press .</p>	 <pre> MENU Teletext Mode (0-2): OFF >>> Page >>> Line 8,321 (0/1): Disable >>> Line 9,322 (0/1): Disable >>> Line 10,323 (0/1): Disable >>> </pre>
(5)	<p><Selecting the setting items from the table> Select the parameters using  or  , and then press .</p>	<p>For further details on the setting items and parameters, refer to <Table of teletext setting items> below.</p>
(6)	<p><Setting the parameters> Select the parameters using  or , and then press .</p> <p>Alternatively: Select the parameters using the number keys ( to ), and then press .</p>	
	<p>Upon completion of the settings: Press .</p>	<p>Display returns to the initial screen.</p>

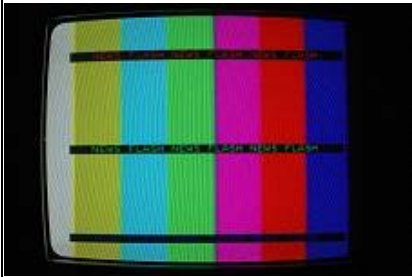
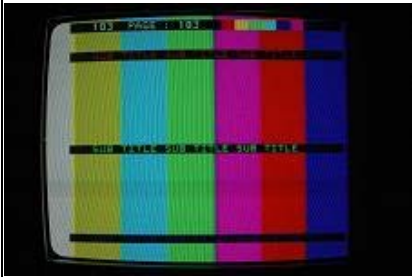





<Table of teletext setting items>

(1)	Mode (0-2)	The Teletext operation mode is selected here.		
		0	Off	Teletext OFF.
		1	Default	The default pages are output. For further details, refer to the teletext default on next pages
		2	Page Select	The pages selected by page in (2) below is output here.
(2)	Page Press <input type="button" value="SET"/> to display the setting menu.			
		This generator enables up to 20 pages of teletext screens to be registered. Numbers for the internal data are set on each page.		
(3)	Line	The lines in which the Teletext data is to be output are set here. The figure indicates the line numbers in the first field and second field.		
		8,321	0 Disable	The data is not output in line 8 and line 321.
			1 Enable	The data is output in line 8 and line 321.
		9,322	Same setting as above.	
		10,323	Same setting as above.	
		• •		
22,335	Same setting as above.			

■ Teletext default pages (page 1 of 2)

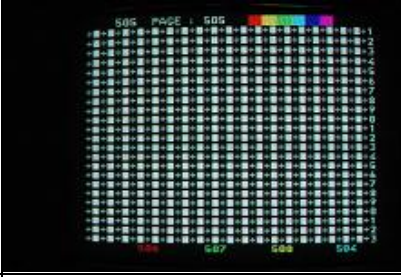
Page No.	Description	Screen	Page No.	Description	Screen
100	Index Page		101	Test Page	
					Including FLASH, CONCEAL
102	Newsflash		103	Subtitle	
200	Character (English)		201	Character (German)	
202	Character (Swedish /Finnish /Hungarian)		203	Character (Italian)	
204	Character (French)		205	Character (Portuguese /Spanish)	

■ Teletext default pages (page 2 of 2)

Page No.	Description	Screen	Page No.	Description	Screen
206	Character (Czech /Slovak)		301	Colors	
302	White Flat		505	Clock Cracker	
515	Multi Page	 <p>4 sub-pages</p>	555	Test Pattern1	
560	Test Pattern2		-	Other pages	 <p>Screen which appears for page 700</p>

5.4 WSS

5.4.1 Description and specifications

■ What is WSS (Wide Screen Signaling)?

“WSS (Wide Screen Signaling)” is a system for multiplexing the aspect ratio information of the images in the vertical sync blanking interval, and sending it.

■ WSS specifications

WSS supports the following TV signals.

WSS is superimposed onto the composite signals and Y/C signals.

- PAL, PAL-N, PAL-Nc
- SECAM

The aspect ratio information of WSS is superimposed on line 23 of the first field. The WSS waveform consists of Run-In, Start Code and the 14-bit data. This waveform and the bit allocation are shown below.

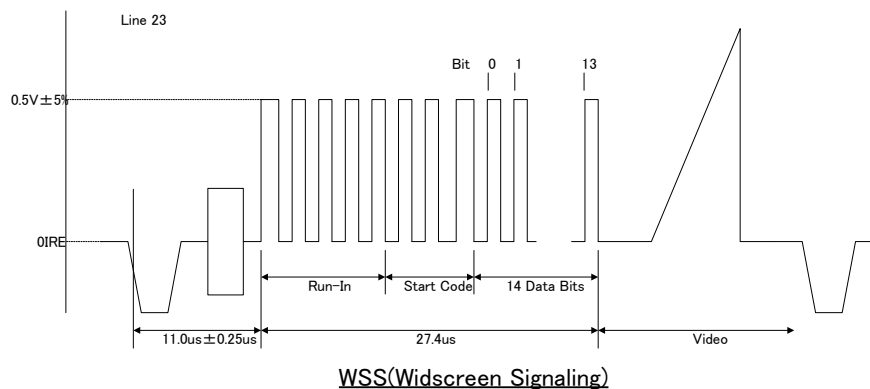

























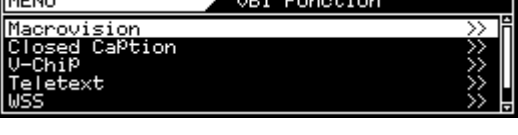







- Bit3-0: Aspect

Bit		Aspect Ratio	Full format or Letterbox	Position
0 1 2	3			
0 0 0	1	4:3	Full format	Not applicable
1 0 0	0	14:9	Letterbox	Center
0 1 0	0	14:9	Letterbox	Top
1 1 0	1	16:9	Letterbox	Center
0 0 1	0	16:9	Letterbox	Top
1 0 1	1	>16:9	Letterbox	Center
0 1 1	1	14:9	Full format	Center
1 1 1	0	16:9	Full format	Not applicable

Bit 3 is the parity bit.

- Bit4-13: Other service information (not supported by the VG-870B/871B/873/874)

5.4.2 Setting procedure

(1)	<p>Select Program Edit using  →  or  , and then press .</p>	 <pre> MENU Program Edit Program Name : PAL 4:3 Timing (TIM) >>> Output (TIM) >>> Audio (TIM) >>> Pattern (PAT) >>> </pre>
(2)	<p>Select Output using  or  , and then press .</p>	 <pre> MENU Output All Output >>> Analog Output >>> Digital Output >>> VBI Function >>> </pre>
(3)	<p>Select VBI Function using  or  , and then press .</p>	 <pre> MENU VBI Function Macrovision >>> Closed Caption >>> U-Chip >>> Teletext >>> WSS >>> </pre>
(4)	<p>Select WSS using  or  , and then press .</p>	 <pre> MENU WSS OFF/ON (0/1): OFF Aspect Ratio(0-7): Full Format 4:3 </pre>
(5)	<p><Selecting the setting items from the table> Select the parameters using  →  or  , and then press .</p>	<p>For further details on the setting items and parameters, refer to <Table of WSS setting items> below.</p>
(6)	<p><Setting the parameters> Select the parameters using  or  , and then press .</p> <p>Alternatively: Select the parameters using the number keys ( to ), and then press .</p>	
	<p>Upon completion of the settings: Press .</p>	<p>Display returns to the initial screen.</p>

<Table of WSS setting items>

(1)	OFF/ON (0/1)	Whether the WSS information is to be output is set here.	
		0	OFF The WSS information is not output.
		1	ON The WSS information is output.
(2)	Aspect Ratio (0-7)	The aspect ratio is set here.	
		0	The aspect ratio is set to Full Format 4:3 .
		1	The aspect ratio is set to LB 14:9 center .
		2	The aspect ratio is set to LB 14:9 top .
		3	The aspect ratio is set to LB 16:9 center .
		4	The aspect ratio is set to LB 16:9 top .
		5	The aspect ratio is set to LB >16:9 center .
		6	The aspect ratio is set to Full Format 14:9 .
7	The aspect ratio is set to Full Format 16:9 .		

5.5 CGMS -A/ID-1

5.5.1 Description and specifications

■ What is CGMS-A (Copy Generation Management System)?

CGMS-A is a system of multiplexing the copy control information in the vertical sync blanking intervals, and sending it.

■ What is ID-1?

ID-1 is a system of multiplexing the aspect ratio information in the vertical sync blanking intervals, and sending it.

- NTSC, NTSC-M, NTSC-443
- PAL-60, PAL-M

CGMS-A and ID-1 are superimposed onto line 20 (first field) and line 283 (second field). The CGMS-A and ID-1 waveform consists of the reference bit and 20-bit data. This waveform and the bit allocation are shown below.

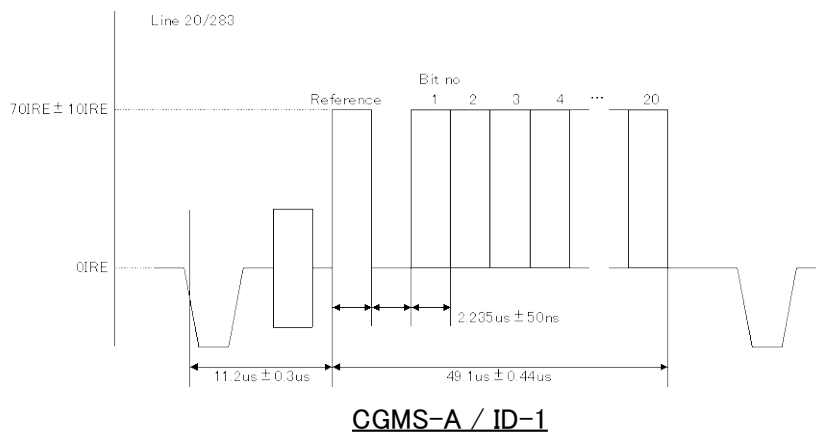

- Bit1-0: Aspect (ID1)

Bit		Applications	
1	2	Aspect ratio	Picture display format
0	0	4:3	Normal
1	0	16:9	Normal
0	1	4:3	Letter Box
1	1	Not Defined	































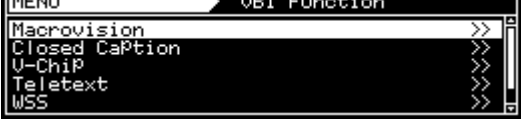





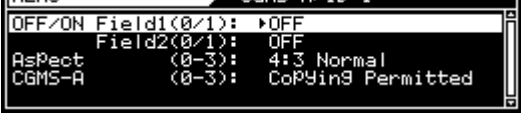







- Bit6-2: Fixed at "0000"

- Bit8-7: CGMS-A

Bit	Application
7 8	
0 0	Copy is permitted without restriction
1 0	Condition not to be used
0 1	One generation of copies may be made
1 1	No copying is permitted

- Bit14-9: Other service information (not supported by the VG-870B/871B/873/874)
- Bit20-15: CRC

5.5.2 Setting procedure

<p>(1) Select Program Edit using    or  INC  DEC  , and then press .</p>	
<p>(2) Select Output using   or  INC  DEC , and then press .</p>	
<p>(3) Select VBI Function using   or  INC  DEC  , and then press .</p>	
<p>(4) Select CGMS-A/ID-1 using   or  INC  DEC  , and then press .</p>	
<p>(5) <Selecting the setting items from the table> Select the parameters using    or  INC  DEC  , and then press .</p>	<p>For further details on the setting items and parameters, refer to <Table of the CGMS-A and ID-1 setting items> below.</p>
<p>(6) <Setting the parameters> Select the parameters using   or  INC  DEC  , and then press .</p> <p>Alternatively: Select the parameters using the number keys ( to ), and then press .</p>	
<p>Upon completion of the settings: Press .</p>	<p>Display returns to the initial screen.</p>

<Table of the CGMS-A and ID-1 setting items>

(1)	OFF/ON Field1 (0/1)	Whether to output the data to line 20 of the first field is set here.		
		0	OFF	The data is not output.
		1	ON	The data is output.
(2)	OFF/ON Field2 (0/1)	Whether to output the data to line 283 of the second field is set here.		
		0	OFF	The data is not output.
		1	ON	The data is output.
(3)	Aspect	The aspect ratio setting is selected here.		
		0	4:3 Normal	The aspect ratio is set to 4:3.
		1	16:9 Normal	The aspect ratio is set to 16:9.
		2	4:3 Letter Box	The aspect ratio is set to 4:3 letter box.
		3	Not Defined	The aspect ratio is left undefined.
(4)	CGMS-A	Copy protection is set here.		
		0	Copying Permitted	Copying is permitted.
		1	Not Used Condition	The CGMS-A is left undefined.
		2	Copy Once	Copy-once is set.
		3	No Copying Permitted	Copying is not permitted.

* The same data is superimposed onto line 20 and line 283.

6

PATTERN SETTINGS

6.1 Color bar patterns

6.1.1 Types of color bar patterns

When color bars have been selected using the pattern key, for instance, color bar patterns can be selected from among the types listed below.

For further details on pattern selection, refer to “2.1.3 Selecting the pattern data.”

0	CUSTOM	Customized pattern	<p>75%/75% color bars</p> <p>SMPTE color bars</p>
1	100/100-H	100%/100% color bars	
2	100/75-H	100%/75% color bars	
3	75/75-H	75%/75% color bars	
4	SMPTE	SMPTE color bars	
5	RGBW-V	Horizontal color bars	
6	xvYCC 4%	xvYCC 4% color bars	
7	xvYCC 8%	xvYCC 8% color bars	
8	xvYCC 12%	xvYCC 12% color bars	

































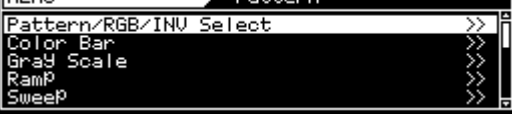











CAUTION













The xvYCC color bars are turned off in the SCART output (RGB) of the TV encoder unit. xvYCC Patterns from other output than HDMI is not displayed correctly.

6.1.2 Color bar pattern customizing

Described below is the procedure for selecting the color bar pattern types and for performing the settings when **CUSTOM** has been selected as the color bar pattern.

(If **CUSTOM** is selected, the color bar patterns can be displayed with any width and color.)

<p>(1) Select Program Edit using  →  or  INC  DEC, and then press .</p>	 <pre> MENU Program Edit Program Name : ▶EIA1920x1080Pa60 Timing (TIM) >>> Output (TIM) >>> Audio (TIM) >>> Pattern (PAT) >>> </pre>
<p>(2) Select Pattern (PAT) using  or   DEC, and then press .</p>	 <pre> MENU Pattern Pattern/RGB/INU Select >>> Color Bar >>> Gray Scale >>> Ramp >>> Sweep >>> </pre>
<p>(3) Select Pattern/RGB/INV select using  or  INC  DEC, and then press .</p>	 <pre> MENU Pattern/RGB/INU Select Color Bar >>> Gray Scale >>> Ramp >>> Sweep >>> Monoscope >>> </pre>
<p>(4) Select Color Bar using  or  INC  DEC, and then press .</p>	 <pre> MENU Pattern/RGB/INU Select Color Bar >>> Gray Scale >>> Ramp >>> Sweep >>> Monoscope >>> </pre>
<p>(5) Press .</p>	 <pre> MENU Pattern Pattern/RGB/INU Select >>> Color Bar >>> Gray Scale >>> Ramp >>> Sweep >>> </pre>
<p>(6) Select Color Bar using  or  INC  DEC, and then press .</p>	 <pre> MENU Color Bar Type (0-8): ▶CUSTOM CUSTOM >>> </pre>
<p>(7) <Selecting the items> Select Type using  or  INC  DEC, and then press .</p> <p><Setting the parameters> Select the parameters using  or  INC  DEC, and then press .</p> <p>Alternatively: Select the parameters using the number keys ( to ), and then press .</p> <p><Detailed settings of customized patterns> Select CUSTOM using  or  INC  DEC, and then press .</p>	<p>For further details on the patterns, refer to “6.1.1 Types of color bar patterns.”</p>  <pre> MENU CUSTOM Format (0-3): ▶H direction Repeat : 16 Input Mode (0/1): % Width [%]: H= 6.3 V= 6.3 Color/Level >>> </pre>

(8)	<p>When CUSTOM has been selected as the Type setting</p> <p><Selecting the items></p> <p>Select the items using  or  ,</p> <p>and then press .</p> <p><Inputting the parameters></p> <p>Select the parameters using  or </p> <p> , and then press .</p> <p>Alternatively:</p> <p>Select the parameters using the number keys</p> <p> to , and then press .</p>	<p>For further details on the settings, refer to <Table of customized color bar pattern setting items> below.</p>
-----	--	--

<Table of customized color bar pattern setting items>

(1)	Format (0-3)	The drawing direction of the color bars is set here.			
		0	H Direction Horizontal direction		
		1	V Direction Vertical direction		
		2	H Direction&div.V Horizontal direction (loopback by Repeat)		
		3	V Direction&div.H Vertical direction (loopback by Repeat)		
(2)	Repeat	One or more of the 1 to 16 data set by Color/Level are set here. The value set here becomes the number of colors which are displayed. Range: 1 to 16			
(3)	Input Mode (0/1)	The method of specifying the display size per color is set here.			
		0	% The size is set as a percentage of the entire screen.		
(4)	Width [%] Width [dot]	The display size per color is set here.			
		When a percentage is used for Input Mode Set any width from 0.0% to 100.0%.			
		When dots are used for Input Mode Set the width in 1-dot increments.			
(5)	Color/Level	The display color and level are set here.			
		Number	The colors from 1 to the Repeat setting are used for the display.		
		Color	The display colors are selected here.		
			0	___	Black
			1	R __	Red
			2	_ G _	Green
			3	R G _	Yellow
			4	__ B	Blue
			5	R _ B	Magenta
6	_ G B		Cyan		
7	R G B	White			
Level	The level as a percentage of the peak brightness is set here. Setting range: 0.0 to 100.0%				

6.2 Gray scale patterns

6.2.1 Types of gray scale patterns

When gray scale has been selected using the pattern key, for instance, gray scale patterns can be selected from among the types listed below.



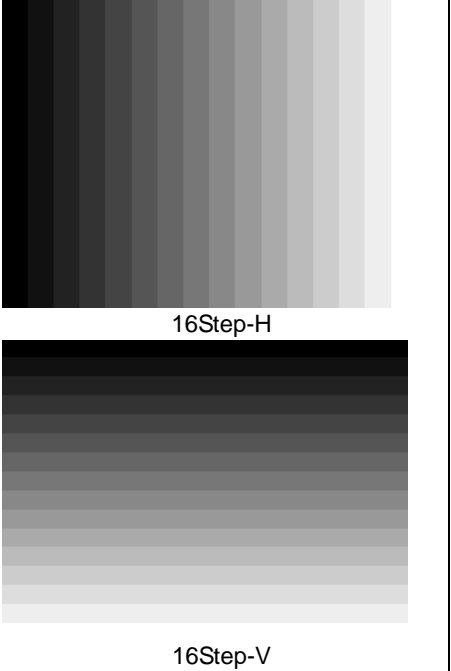

























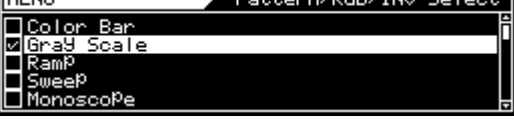

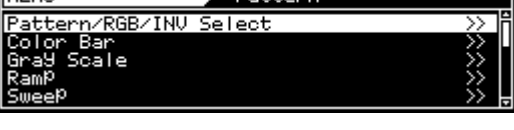



For further details on pattern selection, refer to “2.1.3 Selecting the pattern data.”

















0	CUSTOM	Customized pattern	
1	8Step-H	8 steps (horizontal)	
2	16Step-H	16 steps (horizontal)	
3	32Step-H	32 steps (horizontal)	
4	8Step-V	8 steps (vertical)	
5	16Step-V	16 steps (vertical)	
6	32Step-V	32 steps (vertical)	

6.2.2 Gray scale pattern customizing

Described below is the procedure for selecting the types of gray scale patterns and for performing the settings when **CUSTOM** has been selected as the gray scale pattern.

(If **CUSTOM** is selected, the color bar patterns can be displayed with any width and level.)

<p>(1) Select Program Edit using   or  , and then press .</p>	 <pre> MENU Program Edit Program Name : ▶EIA1920x1080Pa60 Timing (TIM) >>> Output (TIM) >>> Audio (TIM) >>> Pattern (PAT) >>> </pre>
<p>(2) Select Pattern (PAT) using  or , and then press .</p>	 <pre> MENU Pattern Pattern/RGB/INU Select >>> Color Bar >>> Gray Scale >>> Ramp >>> Sweep >>> </pre>
<p>(3) Select Pattern/RGB/INV select using  or  , and then press .</p>	 <pre> MENU Pattern/RGB/INU Select Color Bar >>> Gray Scale >>> Ramp >>> Sweep >>> Monoscope >>> </pre>
<p>(4) Select Gray Scale using  or , and then press .</p>	 <pre> MENU Pattern/RGB/INU Select Color Bar >>> Gray Scale >>> Ramp >>> Sweep >>> Monoscope >>> </pre>
<p>(5) Press .</p>	 <pre> MENU Pattern Pattern/RGB/INU Select >>> Color Bar >>> Gray Scale >>> Ramp >>> Sweep >>> </pre>
<p>(6) Select Gray Scale using  or , and then press .</p>	 <pre> MENU Gray Scale Type (0-6): ▶CUSTOM >>> CUSTOM >>> </pre>
<p>(7) <Selecting the items> Select Type using  or  , and then press .</p> <p><Setting the parameters> Select the parameters using  or , and then press .</p> <p>Alternatively: Select the parameters using the number keys ( to ) , and then press .</p>	<p>For further details on the patterns, refer to “6.2.1 Types of gray scale patterns.”</p>

<p>(8) When CUSTOM has been selected as the Type setting</p>	
<p><Detailed settings of customized patterns></p> <p>Select CUSTOM using  or  , and then press .</p>	<p>For further details on the settings, refer to <Table of customized gray scale pattern setting items> below.</p>
<p><Selecting the items></p> <p>Select the items using  or  , and then press .</p>	
<p><Inputting the parameters></p> <p>Select the parameters using  or  , and then press .</p> <p>Alternatively: Select the parameters using the number keys ( to ) , and then press .</p>	

<Table of customized gray scale pattern setting items>

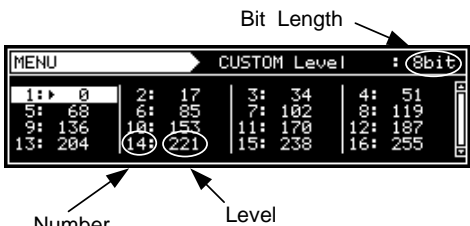
(1)	Format (0-3)	The drawing direction of the gray scale is set here.	
		0	H Direction Horizontal direction
		1	V Direction Vertical direction
		2	H Direction&div.V Horizontal direction (loopback by Repeat)
		3	V Direction&div.H Vertical direction (loopback by Repeat)
(2)	Repeat	One or more of the 1 to 16 data set by Level are set here. The value set here becomes the number of steps which are displayed. Range: 1 to 16	
(3)	Input Mode (0/1)	The method of specifying the display size per step is set here.	
		0	% The size is set as a percentage of the entire screen.
(4)	Width[%] Width[dot]	The display size per step is set here.	
		When a percentage is used for Input Mode Set any size from 0.0% to 100.0%.	
		When dots are used for Input Mode Set the size in 1-dot increments.	
(5)	Level	The display level is set here.	
			
		Number	The steps from 1 to the Repeat setting are used for the display.
		Level	The level is set here. The setting range differs depending on the color depth .
		8 BIT	0 to 255
		9 BIT	0 to 511
		10 BIT	0 to 1023
		11 BIT	0 to 2047
		12 BIT	0 to 4095
		13 BIT	0 to 8191
14 BIT	0 to 16383		
15 BIT	0 to 32767		
16 BIT	0 to 65535		



6.3 Ramp patterns

6.3.1 Types of ramp patterns

When ramp has been selected using the pattern key, for instance, ramp patterns can be selected from among the types listed below.

For further details on pattern selection, refer to “2.1.3 Selecting the pattern data.”

0	CUSTOM	
1	Linear-H	
2	Linear-V	
3	Linear-256	
4	RGB1	
5	RGB2	
6	RGB3	
7	Turn-H	
8	Linear-GR	
9	Linear-BR	
A	Linear-BG	
B	Linear-RG	
C	Linear-RB	
D	Linear-GB	
E	Linear-HV	
F	Limited-H	
-	Limited-V	
-	H2-UpUp	
-	H2-DownUp	
-	H2-UpDown	
-	H2-DownDwn	
-	V2-UpUp	
-	V2-DownUp	
-	V2-UpDown	
-	V2-DownDwn	

*1 Limited-V is selectable only by  or .







































*2 The luminance level of Limited-H/V is 16-232 and color-difference level is 16-240.

*3 The luminance level from H2-UpUp to V2-DownDwn is incremented (Up) from 0 to 255 and decremented (Down) from 255 to 0.

6.3.2 Ramp pattern type settings and customizing





Described below is the procedure for selecting the types of ramp patterns and for performing the settings when **CUSTOM** has been selected as the ramp pattern type.





(If **CUSTOM** is selected, the ramp patterns can be displayed with any level and steps.)

<p>(1) Select Program Edit using  →  or  , and then press .</p>	 <pre> MENU → Program Edit Program Name : ▶EIA1920x1080Pa60 Timing (TIM) >>> Output (TIM) >>> Audio (TIM) >>> Pattern (PAT) >>> </pre>
<p>(2) Select Pattern (PAT) using  or  , and then press .</p>	 <pre> MENU → Pattern Pattern/RGB/INU Select >>> Color Bar >>> Gray Scale >>> Ramp >>> Sweep >>> </pre>
<p>(3) Select Pattern/RGB/INV select using  or  , and then press .</p>	 <pre> MENU → Pattern/RGB/INU Select <input type="checkbox"/> Color Bar <input type="checkbox"/> Gray Scale <input type="checkbox"/> Ramp <input type="checkbox"/> Sweep <input type="checkbox"/> Monoscope </pre>
<p>(4) Select Ramp using  or  , and then press .</p>	 <pre> MENU → Pattern/RGB/INU Select <input type="checkbox"/> Color Bar <input type="checkbox"/> Gray Scale <input checked="" type="checkbox"/> Ramp <input type="checkbox"/> Sweep <input type="checkbox"/> Monoscope </pre>
<p>(5) Press .</p>	 <pre> MENU → Pattern Pattern/RGB/INU Select >>> Color Bar >>> Gray Scale >>> Ramp >>> Sweep >>> </pre>
<p>(6) Select Ramp using  or  , and then press .</p>	 <pre> MENU → Ramp Type (0-E): ▶Linear-HV >> CUSTOM >>> </pre>
<p>(7) <Setting the type> Select Type using  or  , and then press .</p> <p><Setting the parameters> Select the parameters using  or  , and then press .</p> <p>Alternatively: Select the parameters using the number keys ( to ) , and then press .</p>	<p>For further details on the patterns, refer to “6.3.1 Types of ramp patterns.”</p>





(8) When **CUSTOM** has been selected as the **Type** setting





<Detailed settings of customized patterns>

Select **CUSTOM** using  or  ,
and then press .

Select the items using  or  ,
and then press .

<Inputting the parameters>

Select the parameters using  or 
 , and then press .

Alternatively:
0/STATUS 9/F ↗ 
( to ), and then press .

```

MENU          CUSTOM          : 8bit
Direction(0/1): ▶H
H-Line       : 1
Level Line1  : 0      255    16
Level Line2  : 0      255    32
              (Start) (End) (Step)

```

For further details on the settings, refer to **<Table of ramp pattern setting items>** below.

<Table of ramp pattern setting items>

(1)	Direction (0/1)	The resolution is set here.	
		0	H Horizontal ramp
		1	V Vertical ramp
(2)	H-Line	Up to four ramp patterns with different levels and steps can be displayed on one screen. Range: 1 to 4 types. These types are used in sequence from line 1.	
(3)	Line1 to Line4	The start level, end level and step are set here.	
		(Start)	The start level is set here.
		(End)	The end level is set here.
		(Step)	The number of display steps from the start level to end level is set here. Setting range: $1 \leq \text{setting} \leq (\text{End}) - (\text{Start}) + 1$
		The setting range for the above levels differs depending on the color depth .	
		8 BIT	0 to 255
		9 BIT	0 to 511
		10 BIT	0 to 1023
		11 BIT	0 to 2047
12 BIT	0 to 4095		
13 BIT	0 to 8191		
14 BIT	0 to 16383		
15 BIT	0 to 32767		
16 BIT	0 to 65535		

- * Concerning H-Line
This item takes effect only when "0" has been selected as the Direction setting.
- * Concerning Direction
When "1" has been selected as the Direction setting, only "1" takes effect as the H-Line setting. (Splitting in the vertical direction is not possible.)

6.4 Sweep patterns

6.4.1 Types of sweep patterns





































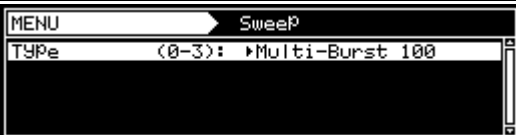

When sweep has been selected using the pattern key, for instance, sweep patterns can be selected from among the types listed below.

For further details on pattern selection, refer to “2.1.3 Selecting the pattern data.”

0	Multi-Burst 100	Multi-burst	 <p>Multi-burst</p>
1	Multi-Burst 50	Multi-burst	
2	Sweep	Sweep	

6.4.2 Sweep pattern selection

The types of sweep patterns can be set using the procedure below.

(1)	<p>Select Program Edit using  →  or  , and then press .</p>	 <pre> MENU → Program Edit Program Name : ▶EIA1920x1080P60 Timing (TIM) >> Output (TIM) >> Audio (TIM) >> Pattern (PAT) >> </pre>
(2)	<p>Select Pattern (PAT) using  or  , and then press .</p>	 <pre> MENU → Pattern Pattern/RGB/INU Select >> Color Bar >> Gray Scale >> Ramp >> Sweep >> </pre>
(3)	<p>Select Pattern/RGB/INU select using  or  , and then press .</p>	 <pre> MENU → Pattern/RGB/INU Select [] Color Bar [] Gray Scale [] Ramp [] Sweep [] Monoscope </pre>
(4)	<p>Select Sweep using  or  , and then press .</p>	 <pre> MENU → Pattern/RGB/INU Select [] Color Bar [] Gray Scale [] Ramp [✓] Sweep [] Monoscope </pre>
(5)	<p>Press .</p>	 <pre> MENU → Pattern Pattern/RGB/INU Select >> Color Bar >> Gray Scale >> Ramp >> Sweep >> </pre>
(6)	<p>Select Sweep using  or  , and then press .</p>	 <pre> MENU → Sweep Type (0-3): ▶Multi-Burst 100 </pre>
(7)	<p><Selecting the items> Select Type using  or  , and then press .</p> <p><Setting the parameters> Select the parameters using  or  , and then press .</p> <p>Alternatively: Select the parameters using the number keys ( to ) , and then press .</p>	<p>For further details on the patterns, refer to “6.4.1 Types of sweep patterns.”</p>

6.5 Monoscope patterns

6.5.1 Types of monoscope patterns

When monoscope has been selected using the pattern key, for instance, monoscope patterns can be selected from among the types listed below.

For further details on pattern selection, refer to “2.1.3 Selecting the pattern data.”

0	SMPTE RP-133	
1	SMPTE PR-133 Color	
2	MONOSCOPE	
3	PHILIPS	
4	CHINA	
5	SDI Check Field	*2
6	APDC1	*1
7	APDC2	*1
8	APDC3	*1
9	APDC4	*1
A	APDC5	*1

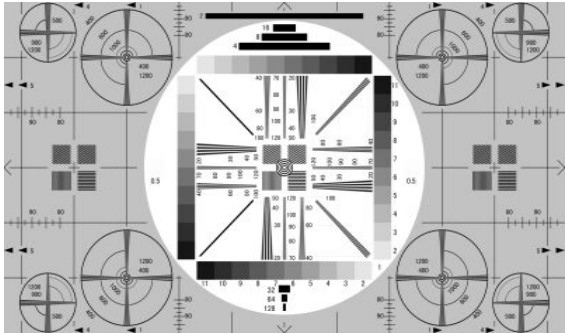























MONOSCOPE



















*1 APDC1 to APDC5 are used to evaluate movie resolution. These patterns are an option. For further details, contact ASTRODESIGN sales representative or your dealer.

*2 This is the check pattern which is used only for SDI outputs. It is output only from SDI outputs.

6.5.2 Monoscope pattern selection

The types of monoscope patterns can be set using the procedure below.

(1)	Select Program Edit using  →  or   , and then press  .	
(2)	Select Pattern (PAT) using  or   , and then press  .	
(3)	Select Pattern/RGB/INV select using  or    , and then press  .	
(4)	Select Monoscope using  or   , and then press  .	

(5)	Press  .						
(6)	Select Monoscope using  or  , and then press  , and then press  .						
(7)	<p><Selecting the items></p> Select Type using  or   , and then press  . <p><Setting the parameters></p> Select the parameters using  or  , and then press  , and then press  . Alternatively: Select the parameters using the number keys  to  , and then press  .	For further details on the patterns, refer to “6.5.1 Types of monoscope patterns.”					
(8)	<p>When the type setting is APDC1 to 5.</p> <p>APDC 4K Mode Note) this is display only. Can not be edit.</p>	APDC patterns for 4Kx2K timings. <table border="1" data-bbox="753 990 1380 1169"> <tr> <td data-bbox="753 990 912 1079">Mode 1</td> <td data-bbox="917 990 1380 1079">HD resolution picture is displayed in center when 4Kx2K timing is selected. Internal pattern #1116-1120.</td> </tr> <tr> <td data-bbox="753 1086 912 1169">Mode 2</td> <td data-bbox="917 1086 1380 1169">Four HD resolution pictures are displayed when 4Kx2K timing is selected. Internal pattern #1196-1200.</td> </tr> </table>		Mode 1	HD resolution picture is displayed in center when 4Kx2K timing is selected. Internal pattern #1116-1120.	Mode 2	Four HD resolution pictures are displayed when 4Kx2K timing is selected. Internal pattern #1196-1200.
Mode 1	HD resolution picture is displayed in center when 4Kx2K timing is selected. Internal pattern #1116-1120.						
Mode 2	Four HD resolution pictures are displayed when 4Kx2K timing is selected. Internal pattern #1196-1200.						

6.6 Raster patterns

6.6.1 Types of raster patterns

When raster has been selected using the pattern key, for instance, raster patterns can be selected from among the types listed below.





























For further details on pattern selection, refer to “2.1.3 Selecting the pattern data.”























0	CUSTOM	
1	White	
2	Red	
3	Green	
4	Blue	
5	Black	
6	50%-Gray	

Raster pattern

6.6.2 Raster pattern type settings and customizing

Described below is the procedure for selecting the types of raster patterns and for performing the settings when CUSTOM has been selected as the raster pattern type. (The rasters can be displayed with any level.)

(1)	Select Program Edit using  →  or   , and then press  .	
(2)	Select Pattern (PAT) using  or   , and then press  .	
(3)	Select Pattern/RGB/INV select using  or    , and then press  .	
(4)	Select Raster using  or   and then press  .	
(5)	Press  .	
(6)	Select Raster using  or   and then press  .	



<p>(7) <Setting the type></p> <p>Select Type using  or  , and then press .</p> <p><Setting the parameters></p> <p>Select the parameters using  or , and then press .</p> <p>Alternatively: Select the parameters using the number keys  , and then press .</p>	<p>For further details on the types of patterns, refer to “6.6.1 Types of raster patterns.”</p>																					
<p>(8) When CUSTOM has been selected as the Type setting</p> <p><Detailed settings of customized patterns></p> <p>Select CUSTOM using  or  , and then press .</p> <p>Select the items using  or  , and then press .</p> <p>Alternatively Select the parameters using the number keys  , and then press .</p>	<p style="text-align: center;">Bit Length</p>  <p style="text-align: center;">Level</p> <table border="1" data-bbox="742 851 1385 1223"> <tr> <td rowspan="8" style="vertical-align: top;">R,G,B</td> <td colspan="2">The setting range for the above levels differs depending on the color depth.</td> </tr> <tr> <td>8 BIT</td> <td>0 to 255</td> </tr> <tr> <td>9 BIT</td> <td>0 to 511</td> </tr> <tr> <td>10 BIT</td> <td>0 to 1023</td> </tr> <tr> <td>11 BIT</td> <td>0 to 2047</td> </tr> <tr> <td>12 BIT</td> <td>0 to 4095</td> </tr> <tr> <td>13 BIT</td> <td>0 to 8191</td> </tr> <tr> <td>14 BIT</td> <td>0 to 16383</td> </tr> <tr> <td>15 BIT</td> <td>0 to 32767</td> </tr> <tr> <td>16 BIT</td> <td>0 to 65535</td> </tr> </table>	R,G,B	The setting range for the above levels differs depending on the color depth .		8 BIT	0 to 255	9 BIT	0 to 511	10 BIT	0 to 1023	11 BIT	0 to 2047	12 BIT	0 to 4095	13 BIT	0 to 8191	14 BIT	0 to 16383	15 BIT	0 to 32767	16 BIT	0 to 65535
R,G,B	The setting range for the above levels differs depending on the color depth .																					
	8 BIT		0 to 255																			
	9 BIT		0 to 511																			
	10 BIT		0 to 1023																			
	11 BIT		0 to 2047																			
	12 BIT		0 to 4095																			
	13 BIT		0 to 8191																			
	14 BIT	0 to 16383																				
15 BIT	0 to 32767																					
16 BIT	0 to 65535																					

6.7 Aspect ratio patterns

6.7.1 Types of aspect ratio patterns

When aspect ratio has been selected using the pattern key, for instance, aspect ratio patterns can be selected from among the types listed below.

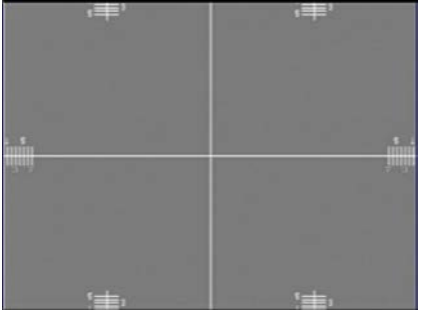









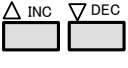







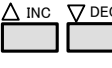

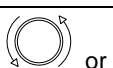
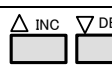



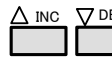

For further details on pattern selection, refer to “2.1.3 Selecting the pattern data.”

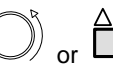
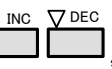
0	Over Scan	 <p style="text-align: center;">Over Scan</p>  <p style="text-align: center;">AFD pattern</p>
	AFD	
0	As the coded frame	
1	4:3 (center)	
2	16:9 (center)	
3	14:9 (center)	
4	box 16:9 (top)	
5	box 14:9 (top)	
6	box 13:7 (center)	
7	box 2:1 (center)	
8	box 11:5 (center)	
9	box 12:5 (center)	
A	4:3 (14:9 center)	
B	16:9 (14:9 center)	
C	16:9 (4:3 center)	

6.7.2 Aspect ratio pattern type settings and customizing





Described below is the procedure for selecting the types of aspect ratio patterns and for performing the settings when **CUSTOM** has been selected as the aspect ratio pattern type.





(If **CUSTOM** is selected, the aspect ratio patterns can be displayed with any level.)

<p>(1) Select Program Edit using  or , and then press .</p>	 <pre> MENU Program Edit Program Name : ▶EIA1920x1080Pa60 Timing (TIM) >>> Output (TIM) >>> Audio (TIM) >>> Pattern (PAT) >>> </pre>
<p>(2) Select Pattern (PAT) using  or , and then press .</p>	 <pre> MENU Pattern Pattern/RGB/INU Select >>> Color Bar >>> Gray Scale >>> Ramp >>> Sweep >>> </pre>
<p>(3) Select Pattern/RGB/INV select using  or , and then press .</p>	 <pre> MENU Pattern/RGB/INU Select Color Bar >>> Gray Scale >>> Ramp >>> Sweep >>> Monoscope >>> </pre>
<p>(4) Select Aspect using  or , and then press .</p>	 <pre> MENU Pattern/RGB/INU Select Raster >>> Aspect >>> Checker >>> Image/OPT >>> Character >>> </pre>
<p>(5) Press .</p>	 <pre> MENU Pattern Pattern/RGB/INU Select >>> Color Bar >>> Gray Scale >>> Ramp >>> Sweep >>> </pre>
<p>(6) Select Aspect using  or , and then press .</p>	 <pre> MENU Aspect Type (0/1): ▶Over Scan >> AFD >>> </pre>
<p>(7) <Setting the type> Select Type using  or , and then press .</p> <p><Setting the parameters> Select the parameters using  or , and then press .</p> <p>Alternatively: Select the parameters using the number keys ( to ), and then press .</p>	<p>For further details on the types of patterns, refer to “6.7.1 Types of aspect ratio patterns.”</p>





(8) When **AFD** has been selected as the **Type** setting



<Detailed settings of AFD patterns>

Select **AFD** using  or  , and then press .

Select the items using  or  , and then press .

<Inputting the parameters>

Select the parameters using  or  , and then press .

Alternatively:
Select the parameters using the number keys ( to ) , and then press .

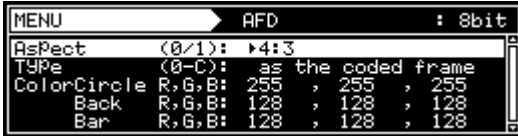

```

MENU          AFD          : 8bit
Aspect      (0/1): 4:3
Type        (0-C): as the coded frame
ColorCircle R,G,B: 255 , 255 , 255
Back       R,G,B: 128 , 128 , 128
Bar        R,G,B: 128 , 128 , 128

```

For further details on the settings, refer to **<Table of AFD pattern setting items>** below.

<Table of AFD pattern setting items>

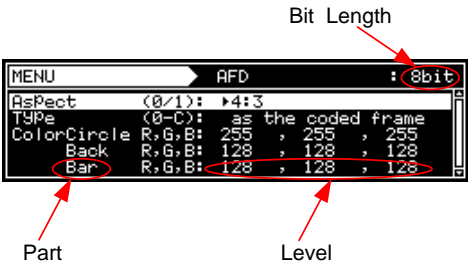
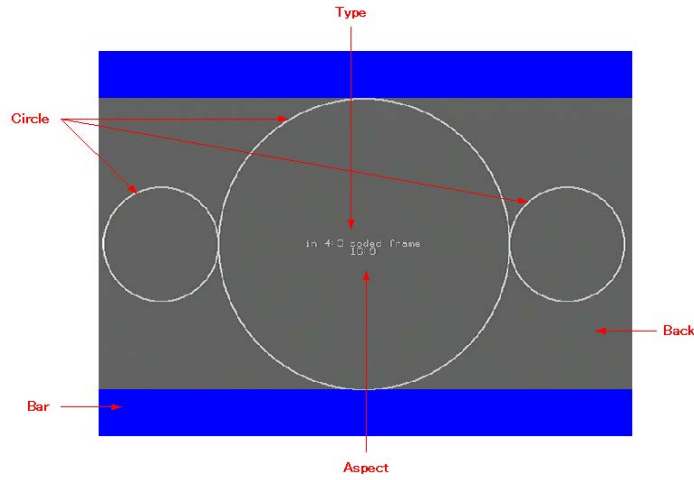
(1)	Aspect (0/1)	The aspect ratio of the screen is set here.																			
		0 4:3	The images are displayed on the screen with a 4:3 aspect ratio.																		
		1 16:9	The images are displayed on the screen with a 16:9 aspect ratio.																		
(2)	Type	For details on the types of patterns, refer to "6.7.1 Types of aspect ratio patterns."																			
(3)	Color																				
																					
		Circle	<p>Display the circle level. The R, G and B levels are displayed in sequence from the left. The setting range for the above level differs depending on the color depth.</p> <table border="1"> <tr><td>8 BIT</td><td>0 to 255</td></tr> <tr><td>9 BIT</td><td>0 to 511</td></tr> <tr><td>10 BIT</td><td>0 to 1023</td></tr> <tr><td>11 BIT</td><td>0 to 2047</td></tr> <tr><td>12 BIT</td><td>0 to 4095</td></tr> <tr><td>13 BIT</td><td>0 to 8191</td></tr> <tr><td>14 BIT</td><td>0 to 16383</td></tr> <tr><td>15 BIT</td><td>0 to 32767</td></tr> <tr><td>16 BIT</td><td>0 to 65535</td></tr> </table>	8 BIT	0 to 255	9 BIT	0 to 511	10 BIT	0 to 1023	11 BIT	0 to 2047	12 BIT	0 to 4095	13 BIT	0 to 8191	14 BIT	0 to 16383	15 BIT	0 to 32767	16 BIT	0 to 65535
		8 BIT	0 to 255																		
9 BIT	0 to 511																				
10 BIT	0 to 1023																				
11 BIT	0 to 2047																				
12 BIT	0 to 4095																				
13 BIT	0 to 8191																				
14 BIT	0 to 16383																				
15 BIT	0 to 32767																				
16 BIT	0 to 65535																				
Back	Set the background level. (Details are the same as for Color Circle .)																				
Bar	Set the bar level. (Details are the same as for Color Circle .)																				

6.8 Checkerboard patterns

6.8.1 Types of checkerboard patterns





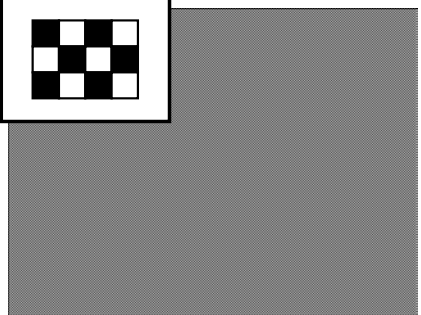
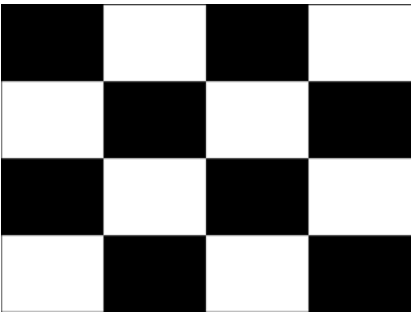
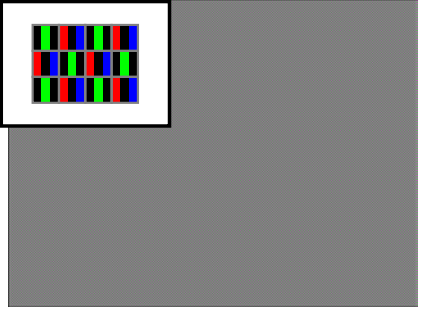



























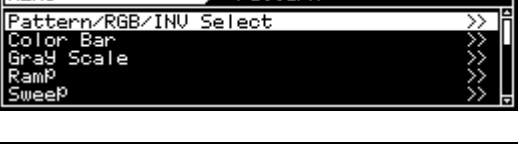



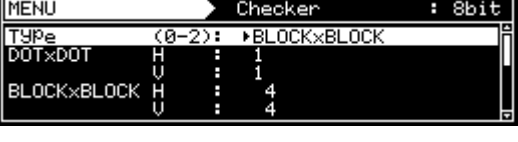

When checkerboard has been selected using the pattern keys or other keys, any of the following types of patterns can be selected.

For further details on pattern selection, refer to “2.1.3 Selecting the pattern data.”





0	DOT x DOT	Dot	
1	BLOCK x BLOCK	Block	
2	SubPixel	Sub-pixel	

6.8.2 Checkerboard pattern customizing

The types of checkerboard patterns are selected and their intervals are set using the procedure below.

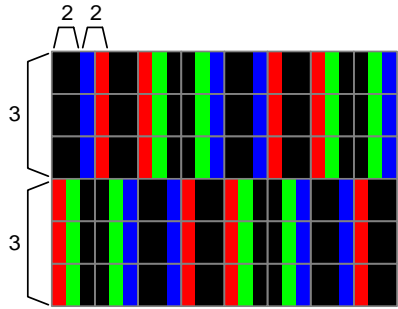
<p>(1) Select Program Edit using  →  or  INC  DEC, and then press .</p>	 <pre> MENU Program Edit Program Name : ▶EIA1920x1080P60 Timing (TIM) >>> OutPut (TIM) >>> Audio (TIM) >>> Pattern (PAT) >>> </pre>
<p>(2) Select Pattern (PAT) using  or  INC  DEC, and then press .</p>	 <pre> MENU Pattern Pattern/RGB/INU Select >>> Color Bar >>> Gray Scale >>> Ramp >>> Sweep >>> </pre>
<p>(3) Select Pattern/RGB/INU select using  or  INC  DEC, and then press .</p>	 <pre> MENU Pattern/RGB/INU Select [] Color Bar [] Gray Scale [] Ramp [] Sweep [] Monoscope </pre>
<p>(4) Select Checker using  or  INC  DEC, and then press .</p>	 <pre> MENU Pattern/RGB/INU Select [] Raster [] Aspect [x] Checker [] Image/OPT [] Character </pre>
<p>(5) Press .</p>	 <pre> MENU Pattern Pattern/RGB/INU Select >>> Color Bar >>> Gray Scale >>> Ramp >>> Sweep >>> </pre>
<p>(6) Select Checker using  or  INC  DEC, and then press .</p>	 <pre> MENU Checker : 8bit Type (0-2): ▶BLOCKxBLOCK DOTxDOT H : 1 U : 1 BLOCKxBLOCK H : 4 U : 4 </pre>
<p>(7) <Selecting the items> Select Type using  or  INC  DEC, and then press .</p> <p><Setting the parameters> Select the parameters using  or  INC  DEC, and then press .</p> <p>Alternatively: Select the parameters using the number keys ( to ), and then press .</p>	<p>For details on the Type settings, refer to “6.8.1 Types of checkerboard patterns.”</p> <p>Depending on the Type setting, the setting items differ. Refer to the <Table of checkerboard setting items>.</p>

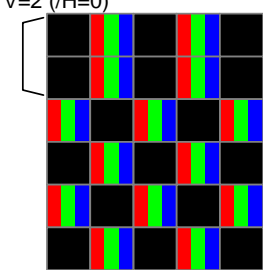
<Table of checkerboard setting items>

(1)	DOTxDOT H/V	<Valid only when DOTxDOT is selected as the Type setting> Set the number of horizontal (H) and vertical (V) pixels for one color. Setting range: 1 to 8						
(2)	BLOCKxBLOCK H/V	<Valid only when BLOCKxBLOCK is selected as the Type setting> Set the number of horizontal (H) and vertical (V) blocks. Setting range: 2 to 32						
(3)	Sub Pixel H/V	<Valid only when Sub Pixel is selected as the Type setting> Set the number of horizontal (H) sub pixels and number of vertical (V) pixels. Setting range: 0 to 3 * When RGB 0%/100% is selected for Color Select, H=1 and V=1 will be set regardless of the settings. Setting example: H=2, V=3  <p>When User Color has been selected</p> <ul style="list-style-type: none"> : User Color 1 is used. : User Color 2 is used. 						
(4)	SubPixel Offset H/V	<Valid only when Sub Pixel is selected as the Type setting> Set the number of sub pixels at the top left in the horizontal (H) direction and the number of pixels at the very top in the vertical (V) direction. (The Sub Pixel H and V settings subsequently apply.) Setting range: 0 to 2 * When RGB 0%/100% is selected for Color Select, H=0 and V=0 will be set regardless of the settings. Setting example: Sub Pixel H=3, V=1, SubPixel Offset H/V = refer to figures. <div style="display: flex; justify-content: space-around;"> <div style="text-align: center;"> <p>Offset H=0 / V=0</p>  </div> <div style="text-align: center;"> <p>V=2 (/H=0)</p>  </div> </div> <div style="margin-top: 10px;"> <p>□ H=1 (V=0)</p>  </div> <div style="margin-top: 10px;"> <p>□ H=2 (V=0)</p>  </div>						
(5)	Color Select (0/1)	This sets the color and level. <table border="1" style="width: 100%; border-collapse: collapse;"> <tbody> <tr> <td style="width: 5%; text-align: center;">0</td> <td style="width: 60%;">RGB 0%/100%</td> <td style="width: 35%;">0% / 100%</td> </tr> <tr> <td style="text-align: center;">1</td> <td>User Color</td> <td>The colors selected using User Color 1 and 2 are used.</td> </tr> </tbody> </table>	0	RGB 0%/100%	0% / 100%	1	User Color	The colors selected using User Color 1 and 2 are used.
0	RGB 0%/100%	0% / 100%						
1	User Color	The colors selected using User Color 1 and 2 are used.						

(6)	User Color 1 R, G, B	<p>When RGB 0%/100% has been selected for Color Select, set any color and level to be indicated by "0%."</p> <p>In the case of the Sub Pixel item, the same level as the RGB level is set.</p> <p>The setting range differs depending on the color depth.</p>	Setting ranges by color depth	
			8BIT	0 – 255
			9BIT	0 – 511
			10BIT	0 – 1023
			11BIT	0 – 2047
			12BIT	0 – 4095
			13BIT	0 – 8191
			14BIT	0 - 16383
			15BIT	0 - 32767
			16BIT	0 - 65535
(7)	User Color 2 R, G, B	<p>When RGB 0%/100% has been selected for Color Select, set any color and level to be indicated by "100%."</p> <p>In the case of the Sub Pixel item, the same level as the RGB level is set.</p> <p>The setting range is the same as for User Color 1.</p>		

6.9 Image/OPT

6.9.1 Types of Image/OPT





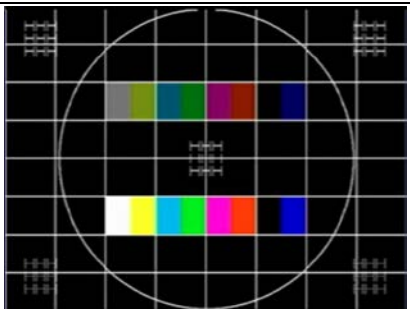

































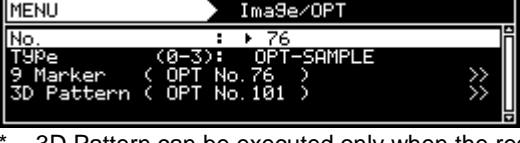

When Image/OPT has been selected using the pattern key, for instance, optional and image patterns can be selected from among the types listed below.

For further details on pattern selection, refer to “2.1.3 Selecting the pattern data.”

0	IMAGE	Image pattern	 <p>IMAGE A still image registered as the default can be used or any still image can be registered by the user and used.</p>
1	OPT-SAMPLE	Sample option pattern	 <p>OPT-SAMPLE</p>
2	OPT-USER	User option pattern	<p>Option pattern registered by the user Any test pattern can be described using a programming language.</p>
3	MOVING-IMAGE (option)	Moving image pattern	<p>Both the factory registered moving images and the user registered moving images can be used.</p>

















6.9.2 Option and image patterns setting

The procedure for setting optional and image patterns is described below.

(1)	Select Program Edit using  →  or  INC  DEC, and then press  .	 <pre> MENU → Program Edit Program Name : ▶EIA1920x1080P60 Timing (TIM) >> OutPut (TIM) >> Audio (TIM) >> Pattern (PAT) >> </pre>
(2)	Select Pattern (PAT) using  or   DEC, and then press  .	 <pre> MENU → Pattern Pattern/RGB/INU Select >> Color Bar >> Gray Scale >> Ramp >> Sweep >> </pre>
(3)	Select Pattern/RGB/INV select using  or   INC  DEC, and then press  .	 <pre> MENU → Pattern/RGB/INV Select Color Bar Gray Scale Ramp Sweep Monoscope </pre>
(4)	Select Image/OPT using  or   DEC, and then press  .	 <pre> MENU → Pattern/RGB/INV Select Raster Aspect Checker Image/OPT Character </pre>
(5)	Press  .	 <pre> MENU → Pattern Pattern/RGB/INV Select >> Color Bar >> Gray Scale >> Ramp >> Sweep >> </pre>
(6)	Select Image/OPT using  or   DEC, and then press  .	 <pre> MENU → Image/OPT No. : ▶ 76 Type (0-3): OPT-SAMPLE 9 Marker (OPT No. 76) >> 3D Pattern (OPT No. 101) >> </pre> <p>* 3D Pattern can be executed only when the requisite license has been registered.</p>
(7)	<Selecting the items> Select the item using  or   DEC, and then press  .	
(8)	<Setting the No.> Select the No. using  or   DEC, and then press  .	No. Specific numbers are allocated to the option and image patterns. The number of the pattern to be displayed is set in No. Setting range: 1 to 200
	<Setting the Type> Select the Type using  or   DEC, and then press  .	Type * For further details on the patterns, refer to "6.9.1 Types of Image/OPT." * When MOV-IMAGE is selected, refer to "6.9.3 Moving images settings (option)" for the detailed procedures.

6.9.3 Moving images settings (option)

The procedure for setting moving images is described below.

<p>(1) Select MOV-IMAGE using  and then press .</p> <p>Alternatively: Select the moving image using the number key  ()</p>	
<p>(2) <Setting the No. of the moving image></p> <p>Select No. +1 or No. -1 using , and then press .</p> <p>Alternatively: Select the No. of the moving image using the number key ( or )</p>	<p>The registered moving images are output. Setting range: 1 to 200</p> <ul style="list-style-type: none"> * The size of the memory in the moving image module is 4GB. It takes approximately 5 minutes to read 4GB of data. * The reading of the No.1 moving image starts automatically when the power is turned on.
<p>(3) <Scrolling the screen></p> <p>Scroll the screen using  or .</p>	
<p>(4) <Scrolling the screen></p> <p>Press the following keys;</p> <p> : Stop</p> <p> : Rewind</p> <p> : Resume/pause</p> <p> : Fast forward</p>	<ul style="list-style-type: none"> * While the data is being read, "Loading..." is displayed, and none of the keys can be operated. * Stop: The first image is displayed. * Rewind: The previous image is displayed. * Resume/pause: The moving image display is resumed or paused. * Fast forward: The next image is displayed.

- * For details on the playback times of moving images, refer to section 11.1.10.
- * The moving image data is registered using the SP-8870. For the recording format, conversion tools and other details, refer to the SP-8870 instruction manual.
- * Use the CF card provided with the moving image module for moving image data registration.





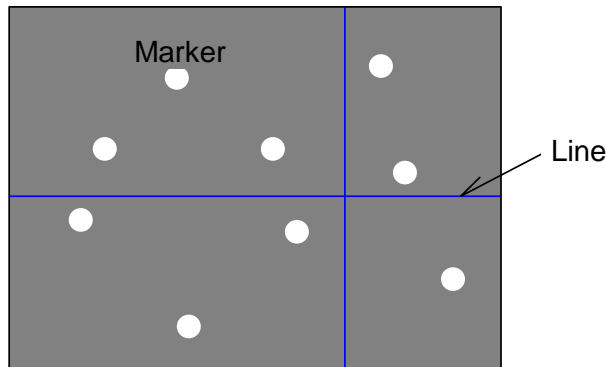





















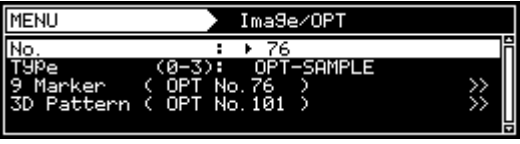





6.9.4 9-marker (OPT No.76) settings

Sample optional pattern No.76 is a pattern which displays up to nine markers and lines at the desired positions.



The setting procedure is given below.

For details on how to display the patterns, refer to "6.9.2 Option and image patterns setting." (Type = OPT-SAMPLE, No.76 specified)

(1)	Select Program Edit using    or   , and then press  .	
(2)	Select Pattern (PAT) using  or   , and then press  .	
(3)	Select Image/OPT using  or   , and then press  .	
(4)	Select 9 Marker (OPT No.76) using  or   , and then press  .	
(5)	<p><Selecting the items></p> Select the items using  or   , and then press  . <p><Setting the parameters></p> Select the parameters using  or   , and then press  . Alternatively: Select the parameters using the number keys ( to ) , and then press  .	For details on the parameters, refer to <Table of 9-marker setting items>.

<Table of 9-marker setting items>

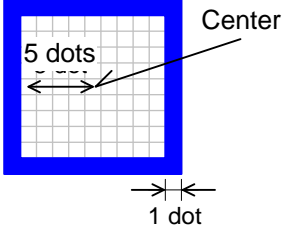
(1)	Mark Shape (0/2)	The shape of the markers is specified here.	
		0 Circle	Circle
		1 Square	Square
(2)	Mark Fill (0/1)	Whether to fill to markers is specified here (disabled when straight line has been selected as the Mark Shape setting).	
		0 OFF (Line)	Markers not filled ○□
		1 ON	Markers filled ●■
(3)	Mark Line Width	The width of the marker frame lines is set here. Setting range: 1 to 15 [dot]	Setting example: Mark Line Width = 1 Mark Size = 5 
		* When "ON" has been selected as the Mark Fill setting, the width will be 1 dot regardless of the setting.	
(4)	Mark Size	The size of the markers is set here. Setting range: 1 to 9999 [dot]	
(5)	Mark Number	The number of the markers is set here. Setting range: 0 to 9	
(6)	Mark Position H,V	The center coordinate of the marker position is set here. Setting range: 0 to 4095 [dot]	
(7)	Mark Direction [H,V]	The direction of the straight line marker is set here.	
		0 H	Horizontal line
		1 V	Vertical line
(8)	Mark Color R,G,B	The color of the markers is set here. The setting range differs depending on the color depth. * See below.	
(9)	Line Mode (0-3)	Whether to display the lines and the shape of the lines when they are displayed are set here.	
		0 None	No lines
		1 V-Line	Vertical line
		2 H-Line	Horizontal line
		3 HV-Line	Cross consisting of one horizontal line and one vertical line
(10)	Line Width	The width of the lines is set here. Setting range: 1 to 15 [dot]	
(11)	Line Position H,V	The positions of the lines are set here. Setting range: 0 to 4095 [dot]	
(12)	Line Color R,G,B	The color of the lines is set here. The setting range differs depending on the color depth. * See below.	

* Color setting range.











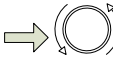













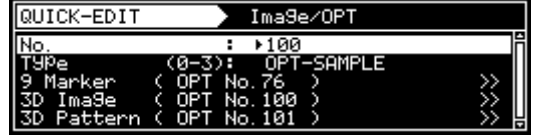

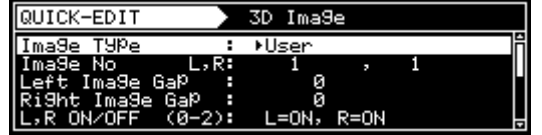
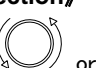

Color Depth	Setting range
8BIT	0 - 255
9BIT	0 - 511
10BIT	0 - 1023
11BIT	0 - 2047
12BIT	0 - 4095
13BIT	0 - 8191
14BIT	0 - 16383
15BIT	0 - 32767
16BIT	0 - 65535

6.9.5 3D Image Pattern (OPT No.100) setting

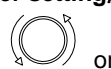
Sample Option Pattern No.100 is 3D Image pattern.
This function is available only for VM-1823.

Besides below setting, the setting in "HDMI Vendor Specific InfoFrame" is referred.

Refer to "6.9.2 Image / OPT setting" about pattern display. (designate Type=OPT-SAMPLE, No.100)

<p>① By using  →  or  , select ProgramEdit → </p>	 <pre> MENU Program Edit Program Name : ▶EIA1920x1080P@60 Timing (TIM) >>> Output (TIM) >>> Audio (TIM) >>> Pattern (PAT) >>> </pre>
<p>② By using  or  , select Pattern (PAT) → </p>	 <pre> MENU Pattern Pattern/RGB/INU Select >>> Color Bar >>> Grad Scale >>> Ramp >>> Sweep >>> </pre>
<p>③ By using  or  , select Image/OPT → </p>	 <pre> QUICK-EDIT Image/OPT No. : ▶100 Type (0-3): OPT-SAMPLE 9 Marker (OPT No. 76) >> 3D Image (OPT No. 100) >> 3D Pattern (OPT No. 101) >> </pre>
<p>④ By using  or  , select 3D Image(OPT No.100) → </p>	 <pre> QUICK-EDIT 3D Image Image Type : ▶User Image No L,R: 1 , 1 Left Image Gap : 0 Right Image Gap : 0 L,R ON/OFF (0-2): L=ON, R=ON </pre>
<p>⑤ 《Item selection》 By using  or  , select item → </p> <p>《Parameter setting》 By using  or  , select it → </p> <p>Or, 0/STATUS  ~  select by number keys → </p>	<p>Refer to 《 3D Image Pattern setting item list 》 about parameter setting.</p>

《 3D Image Pattern setting item list 》

(1)	Image Type (0-2)	Select images.			
		0	User		
		1	MonoScope		
		2	China		
(2)	Image No. L,R	When Image Type is set as 0(User), the image number (user image) selected here is displayed.			
(3)	Left Image Gap	Each image is shift to left direction (minus setting), and right direction (plus setting). Minus value is input by Shift + number keys.			
(4)	Right Image Gap				
(5)	L,R ON/OFF (0-2)	Right and Left picture can be set ON/OFF separately. If you set OFF, the color you set by Off Color is displayed. * This menu is displayed when using Non Interlace timing, or 3D format except frame packing.			
		0	L=ON , R=ON		
		1	L=ON , R=OFF		
		2	L=OFF , R=ON		
(6)	L,R Field ON/OFF	Right and Left field can be set ON/OFF separately. If you set OFF, the color you set by Off Color is displayed in OFF field.. * This menu is displayed when using Interlace timing and frame packing.			
		ON/OFF	0	ON	Output pattern
			1	OFF	Pattern is not output.
(7)	Level L,R	Level of Right and Left pattern can be changed. Setting range : 0 - 100 [%]			
(8)	Off Color R,G,B	Set a color of OFF-frame or OFF-field when you set OFF in « L,R ON/OFF » or « L,R Field ON/OFF » Setting range : 0 – 255			
(9)	Output Mode	Set pattern output mode			
		0	HDMI 3D Structure Pattern is output referring to the setting of « HDMI 3D Structure », This setting is commonly used.		
		1	Frame Sequential The left and the right pattern are displayed by every one frame. In the Simple animation function in the “Action”, set “H=1, V=2” in the “Repeat”, this frame sequential becomes active. Please refer to 6.15.2 Simple Animation		
(10)	L,R Text (0-2)	Set display type of « LEFT » and « RIGHT » character.			
		0	OFF	Not displayed.	
		1	TOP	Display on the top.	
		2	CENTER	Display in center.	
(11)	BkBackLRText(0/1)	Set black background around « LEFT » and « RIGHT » character.			
		0	OFF	Does not set black around « LEFT » and « RIGHT » character.	
		1	ON	Set black around « LEFT » and « RIGHT » character.	
(12)	Sub Sampling(0/1)	In case of « Side by Side » and « Top & Bottom », set it either normal drawing or thin-out drawing. * Refer to p135 “About Sub Sampling”.			
		0	OFF	Normal drawing	
		1	ON	Sub-sampling drawing	

《 3D Image pattern example 》

[0] User

Different images are displayed in each right and left picture.

You select Image No. to each picture.

(Image should be saved beforehand.)

(Example 1080@FramePacking)

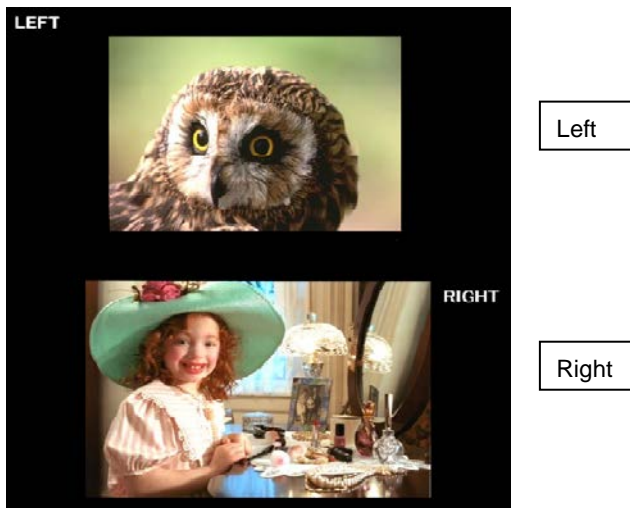

[1] MonoScope

Right and left picture display Monoscope (refer to section 6.5) pattern.

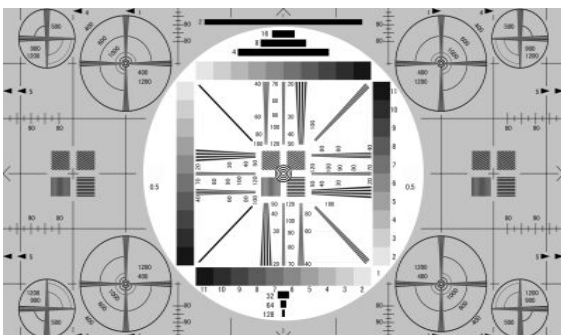

[2] China

Right and left picture display China Monoscope (refer to section 6.5) pattern.

6.9.6 Setting the 3D pattern (OPT No.101)

























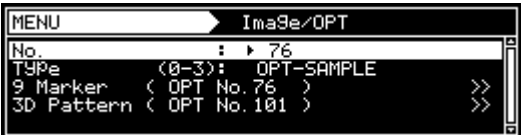

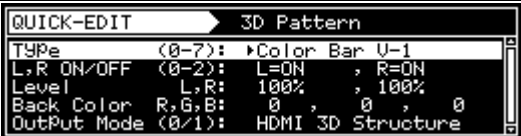

Sample optional pattern No.101 is a 3D pattern.

The requisite license is needed to display this pattern. For details, consult with an ASTRODESIGN sales representative or your distributor.

The setting procedure is given below.

In addition to what is described below, the "HDMI ■ Vendor Specific InfoFrame" setting is referenced.

For details on how to display the pattern, refer to section "6.9.2 Option and image pattern setting."
(Type=OPT-SAMPLE, No.101 specified)

(1)	<p>Select Program Edit using  →  or   , and then press .</p>	
(2)	<p>Select Pattern (PAT) using  or  or  , and then press .</p>	
(3)	<p>Select Image/OPT using  or  or  , and then press .</p>	
(4)	<p>Select 3D Pattern (OPT No.101) using  or  or  , and then press .</p>	
(5)	<p><Selecting the items></p> <p>Select the items using  or  or  , and then press .</p> <p><Setting the parameters></p> <p>Select the parameters using  or  or  , and then press .</p> <p>Alternatively: Select the parameters using the number keys 0/STATUS 9/F  , and then press .</p>	<p>For details of the parameters, refer to <List of 3D pattern setting items>.</p>

<List of 3D pattern setting items>

(1)	Type (0-7)	The type of pattern is selected here.			
		0	Color Bar V-1		
		1	Color Bar V-2		
		2	Vertical Bar		
		3	Checker DOT	The checker pattern settings are referenced.	
		4	Checker BLOCK		
		5	Slant Color Bar		
		6	Slant Gray Bar		
		7	Raster		
		8	$\square \times + \circ$		
		9	Window / Circle		
A	Cross Hatch (it will be referred to Cross Hatch setting).				
(2)	L,R ON/OFF (0-2)	On or Off is selected for the left (L) and right (R) pattern outputs. At the Off setting, the color set using Back Color is output.			
		0	L=ON, R=ON		
		1	L=ON, R=OFF		
2	L=OFF, R=ON				
(3)	L, R Field ON/OFF	On/Off setting of Left and Right patterns by field. The setting color in the Back Color is displayed if it is set off. Note) In case of Interlace signal, or except using Frame Packing mode, it will switch to L, R ON/OFF mode.			
		ON/OFF	0	ON	Pattern is output
			1	OFF	Pattern is not output
(4)	Level L,R	The left (L) and right (R) pattern output levels are set here. Setting range: 0 - 100 [%]			
(5)	Off Color R,G,B	The output color when Off has been selected as the L,R ON/OFF or L, R Field ON/OFF is set here. Setting range: 0 - 255			
(6)	Output Mode	The pattern output mode is specified here.			
		0	HDMI 3D Structure	The HDMI 3D Structure setting is reference, and output. Normally, this setting is specified.	
1	Frame Sequential	The left (L) and right (R) patterns are drawn in the VRAM using one frame for each. The left (L) and right (R) frames can be output alternately by setting Repeat to H=1 and V=2 using the ACTION simple animation function. For details, refer to section "6.15.2 Simple animation settings."			
(7)	L, R Color (0/1)	0	Not use	Pattern is drawn by the original value or designated color set by pattern parameter.	
		1	Use	Pattern and background is drawn by the value set by Left/ Right color in each right and left picture.	
(8)	L, R Text (0-2)	Set display type of « LEFT » and « RIGHT » character.			
		0	OFF	Not displayed.	
		1	TOP	Display on the top.	
2	CENTER	Display in center.			
(9)	BkBackLRText (0/1)	Set black background around « LEFT » and « RIGHT » character.			
		0	OFF	Does not set black around « LEFT » and « RIGHT » character.	
1	ON	Set black around « LEFT » and « RIGHT » character.			

(10)	Sub Sampling (0/1)	In case of « Side by Side » and « Top & Bottom », set it either normal drawing or thin-out drawing.		
		0	OFF	Normal drawing
		1	ON	Thin-out drawing
(11)	Left/Right Color	If you set « Use » in L, R Color , set pattern color and back color in each left and right picture.		
		Coor(L) (R) R,G,B	Set pattern color of each Left and Right picture. Setting range : 0-65535 (max value will change by BitMode.)	
		Back color L) (R) R,G,B	Set back color. Setting range : 0-65535 (max value will change by BitMode.)	
(12)	V.Bar Width (1-16)	If you set « Vertical Bar » in Type , the width of vertical bar can be set. Setting range : 1-16 LANE		
(13)	Slant Angle (0-B)	If you set « Slant Color Bar » or « Slant Gray Bar » in Type , set drawing angle here.		
		0	0 degree	
		1	15 degrees	
		2	30 degrees	
		3	45 degrees	
		A	150 degrees	
		B	165 degrees	
(14)	Checker	A checkerboard pattern is set when Checker DOT or Checker BLOCK has been specified as the Type setting . This is the same setting as the regular checkerboard pattern. (Refer to section "6.8 Checkerboard patterns.")		
(15)	Window / Circle	Set a parameter of Window / Circle that is selected in Type .		
		Type (0-3)	Select kinds of pattern	
		0	Window	Draw one Window.
		1	Circle	Draw one Circle.
		2	9 Window	Draw 9 Windows.
		3	9 Circle	Draw 9 Circles.
		Real Circle (0/1)	In Type , if you select Circle or 9 Circle, select if the circle should be true-circle or not.	
		0	OFF	Draw circle based on H and V size.
		1	ON	Draw true-circle.
		Size H, V	Set the drawing size of the pattern. Setting range : 0-100 [%]	
LPosition RPosition	Set the drawing position of Window / Circle in each Left and Right picture. The setting value becomes the center of the pattern. Setting range : 0-100 [%]			
Position	Set the drawing position of 9 Windows / 9 Circles . The setting value is regarded as the blank area from the edge of screen. Setting range : 0-100 [%]			
(16)	Cross Hatch	If you select Cross Hatch in Type , set the details of Cross Hatch. This is the same setting as the regular Cross Hatch pattern. (Refer to section "6.10.3 Cross Hatch.")		

<3D pattern details>

[0] Color Bar V-1

The same vertical color bars are output at the left and right. "LEFT" and "RIGHT" are displayed for left and right, respectively.

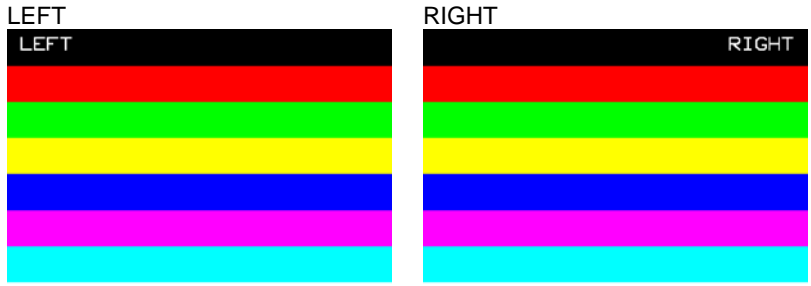

[1] Color Bar V-2

The vertical color bar shown in the figures below are output at the left and right.

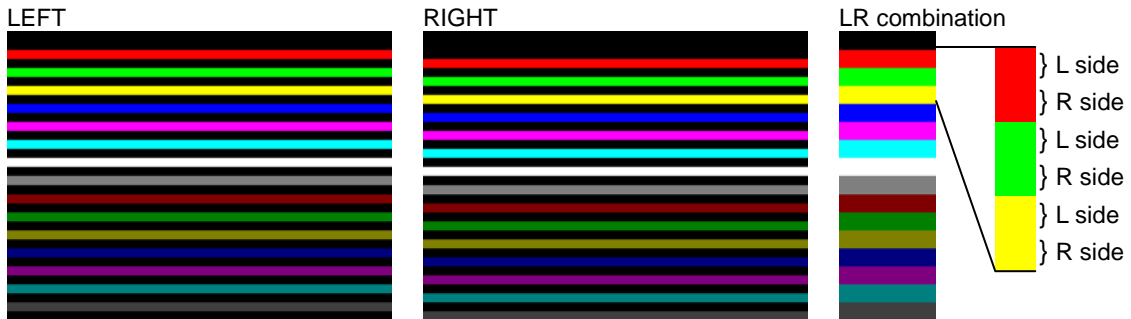

[2] Vertical Bar

Vertical bars each consisting of one dot are output. The pattern is the same for the left and right.

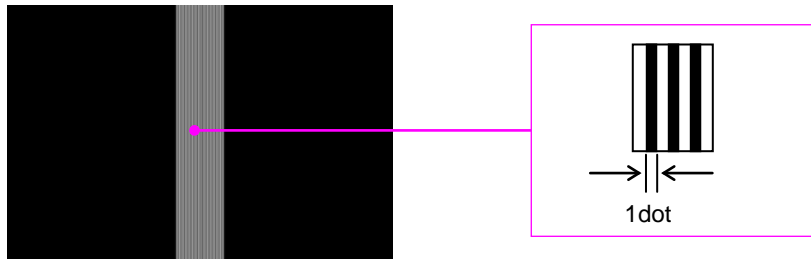

[3] Checker DOT

Checkerboard dot by dot patterns are output. The colors for the pattern on the left are reversed from the colors in the pattern on the right.

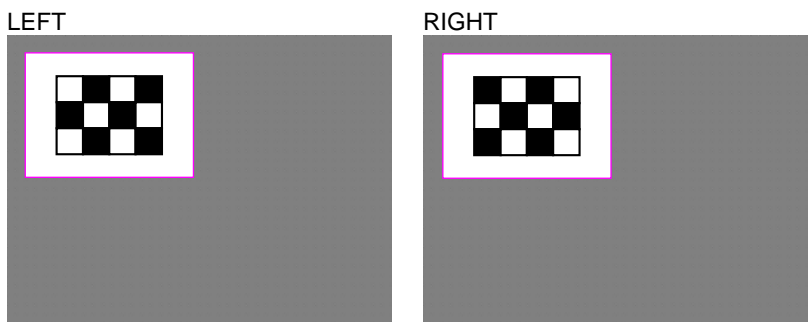

[4] Checker BLOCK

Checkerboard block by block patterns are output. The colors for the pattern on the left are reversed from the colors in the pattern on the right.

The figures below show patterns where the number of blocks is defined as $H=4/V=4$.

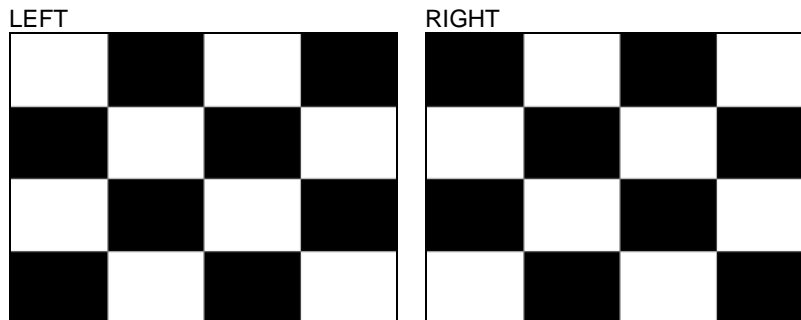

[5] Slant Color Bar, [6] Slant Gray Bar

The different width color bar / gray bar in the slant direction. The right and the left output the same picture. The drawing angle can be changed from 0 – 165 degrees.

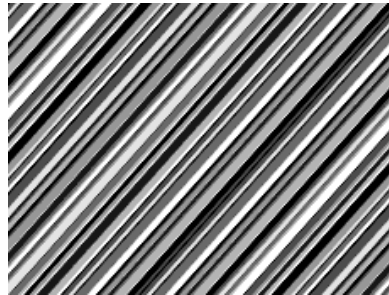
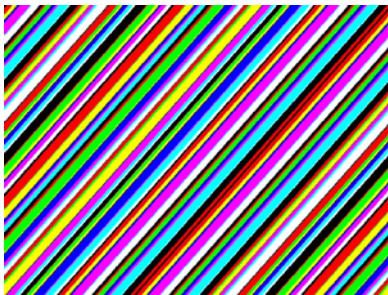

[7] Rastar

A raster is output. The pattern is the same for the left and right.

[8] $\square \times + \circ$

The \square , \times , $+$ and \circ of $\square \times \text{ABC}$ pattern are superimposed and output. The pattern is the same for the left and right.

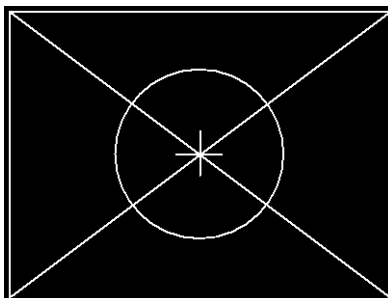

[9-1] Window [9-2] Circle

Window / circle pattern is displayed in the designated position. The left and right frame shows the same picture, but color can be set separately.

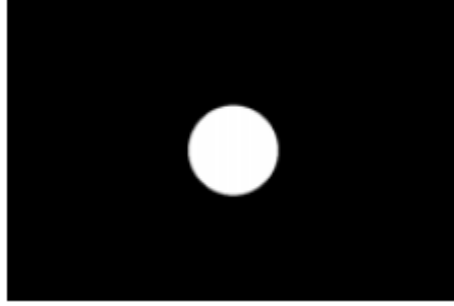

[9-3] 9 Window [9-4] 9 Circle

9 Window patterns are displayed in the designated position. The left and right frame shows the same picture, but color can be set separately.

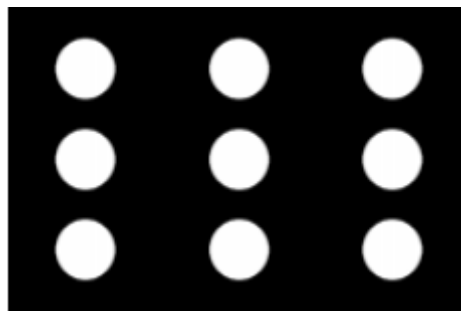

[10] Cross Hatch

Cross hatch is output. The left and right frame shows the same picture, but color can be set separately.

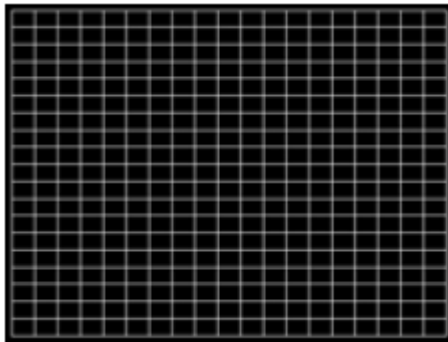

* About Sub Sampling display

In case of Side-by-Side and Top & Bottom, by setting Sub-sampling = OFF, ODD and EVEN line is not taken out and line seems more clear.

Example : Side-by-Side

If Sub Sampling is ON, the pattern is displayed according to the setting in the « 3D Extention Data » in the Vender Specific Infoframe. (e.g. : Type = □ × +○)

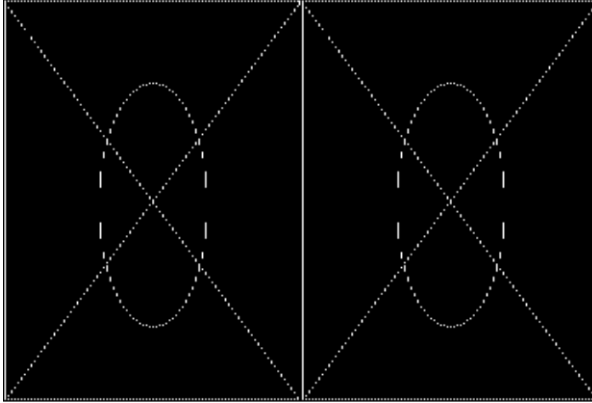

Example : Top & Bottom

If Sub Sampling is ON, only Odd lines are drawn in each left and right picture.

(e.g. : Type = □ × +○)

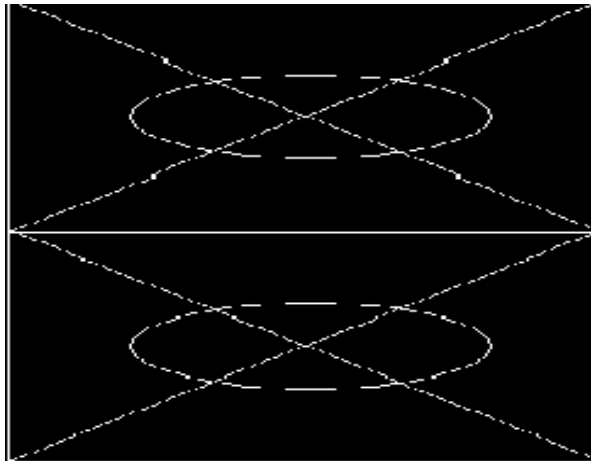

If Sub Sampling is OFF, all lines are drawn by the size of « Sub Sampling = ON », (e.g. Type = □ × +○)

(e.g. Type = □ × +○)

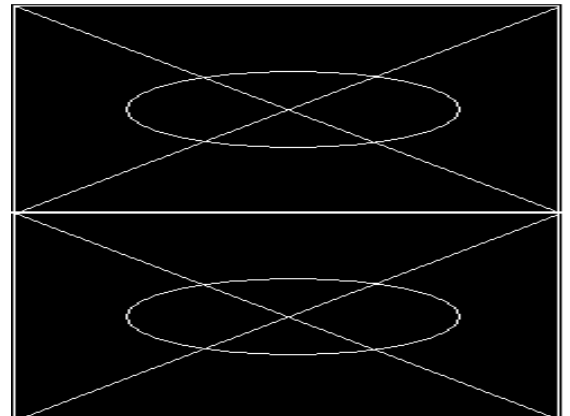
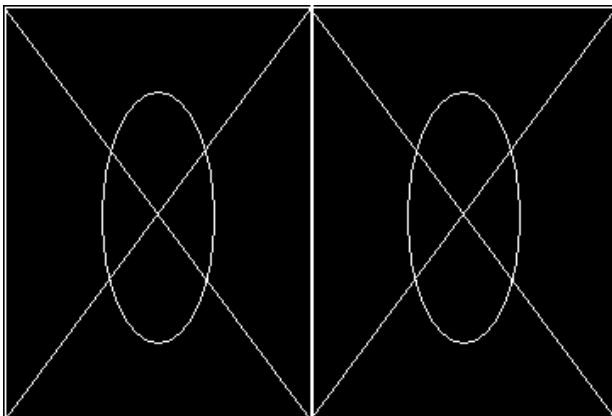





6.10 × ABC patterns

The following patterns are available as × ABC patterns. Select them using the XABC key.

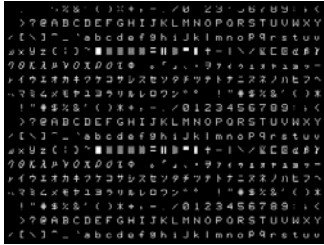
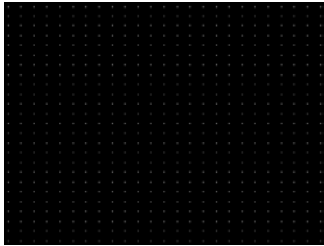
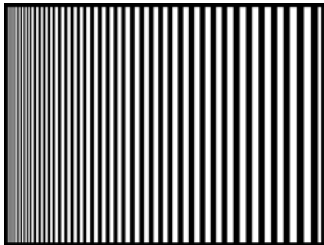
All the patterns can be superimposed onto one another, and displayed.































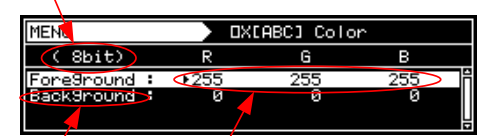

For further details on pattern selection, refer to “2.1.3 Selecting the pattern data.”

Character	Character		
Cross Hatch	Crosshatch		
Dot	Dot		
Circle	Circle		
Burst	Burst		
<input type="checkbox"/>			
×			
+			

* There are no items to be set in , × and + patterns.

6.10.1 Color settings





























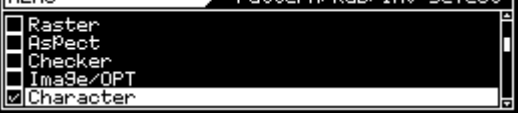











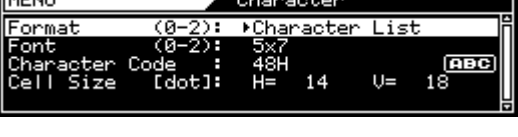

The colors of the $\square \times \text{[ABC]}$ patterns themselves and their background colors can be set.

<p>(1) Select Program Edit using   or  , and then press .</p>					
<p>(2) Select Pattern (PAT) using  or  , and then press .</p>					
<p>(3) Select $\square \times \text{[ABC]}$ using  or  , and then press .</p>					
<p>(4) Select Color using  or  , and then press .</p>	<p>Bit Length</p>  <p>Part Level</p>				
<p>(5) <Setting the items> Select the items using  or  , and then press .</p> <p><Setting the parameters> Select the parameters using  or  , and then press .</p> <p>Alternatively: Select the parameters using the number keys ( to ), and then press .</p>	<table border="1"> <tbody> <tr> <td data-bbox="858 1106 1062 1252">Foreground</td> <td data-bbox="1062 1106 1495 1252">The colors of the $\square \times \text{[ABC]}$ pattern are set here (in the order of RGB from the left). The setting range differs depending on the color depth.</td> </tr> <tr> <td data-bbox="858 1252 1062 1576">Background</td> <td data-bbox="1062 1252 1495 1576">The background color is set here (in the order of RGB from the left). The setting range differs depending on the color depth.</td> </tr> </tbody> </table>	Foreground	The colors of the $\square \times \text{[ABC]}$ pattern are set here (in the order of RGB from the left). The setting range differs depending on the color depth.	Background	The background color is set here (in the order of RGB from the left). The setting range differs depending on the color depth.
Foreground	The colors of the $\square \times \text{[ABC]}$ pattern are set here (in the order of RGB from the left). The setting range differs depending on the color depth.				
Background	The background color is set here (in the order of RGB from the left). The setting range differs depending on the color depth.				

Setting ranges by color depth

8 BIT	0 to 255
9 BIT	0 to 511
10 BIT	0 to 1023
11 BIT	0 to 2047
12 BIT	0 to 4095
13 BIT	0 to 8191
14 BIT	0 to 16383
15 BIT	0 to 32767
16 BIT	0 to 65535

6.10.2 Character patterns



























<p>(1) Select Program Edit using  or  , and then press .</p>	
<p>(2) Select Pattern (PAT) using  or  , and then press .</p>	
<p>(3) Select Pattern/RGB/INU select using  or  , and then press .</p>	
<p>(4) Select Character using  or  , and then press .</p>	
<p>(5) Press .</p>	
<p>(6) Select <input type="checkbox"/> x [ABC] using  or  , and then press .</p>	
<p>(7) Select Character using  or  , and then press .</p>	
<p>(8) <Setting the items> Select the items using  or  , and then press .</p> <p><Setting the parameters> Select the parameters using  or  , and then press .</p> <p>Alternatively: Select the parameters using the number keys ( to ) , and then press .</p>	<p>For further details, refer to <Table of character setting items> below.</p>















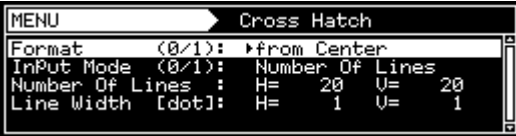

<Table of character setting items>

(1)	Format (0-2)	The format is selected here.	
		0	Character List
		1	All 1-Character
		2	Corner&Center
(2)	Font (0-2)	The font size is set here.	
		0	5 x 7
		1	7 x 9
		2	16 x 16
(3)	Character Code	The character code is selected here. Setting range: 20h to FFh When characters are selected directly, select ABC . For details on the operation procedure, refer to "2.3 Setting the names."	
(4)	Cell Size [dot]	The size of each character is set here.	
		H	Set the size of the character in the horizontal direction.
		V	Set the size of the character in the vertical direction.

6.10.3 Crosshatch patterns

The crosshatch pattern settings are described below.

(1)	<p>Select Program Edit using  →  or  , and then press .</p>	
(2)	<p>Select Pattern (PAT) using  or  or , and then press .</p>	
(3)	<p>Select Pattern/RGB/INV select using  or  , and then press .</p>	
(4)	<p>Select Cross Hatch using  or  or , and then press .</p>	
(5)	<p>Press .</p>	
(6)	<p>Select x [ABC] using  or  or , and then press .</p>	











































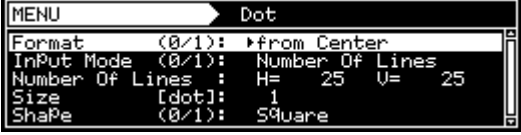

(7)	Select Cross Hatch using  or  , and then press  , and then press  .	
(8)	<p><Setting the items></p> Select the items using  or   , and then press  . <p><Setting the parameters></p> Select the parameters using  or  , and then press  , and then press  . <p>Alternatively: Select the parameters using the number keys ( to ) , and then press .</p>	For further details, refer to <Table of crosshatch setting items> below.

<Table of crosshatch setting items>

(1)	Format (0-2)	The origin point of the pattern drawing is set here.	
		0 From Center	The pattern is drawn using the screen center as the origin point.
		1 From Top-Left	The pattern is drawn using the top left of the screen as the origin point.
(2)	InputMode (0/1)	The input mode is selected here.	
		0 Number Of Line	This sets the number of lines to be displayed on the screen.
		1 Interval (dot)	This sets the interval between the blocks.
(3)-a	When Number of Lines has been selected as the Input Mode setting	The number of lines to be displayed on the screen is set here.	
		Number Of Lines: H =	Set the number of lines in the horizontal direction.
		Number Of Lines: V =	Set the number of lines in the vertical direction.
(3)-b	When Interval (dot) has been selected as the Input Mode setting	The interval between the blocks is set here.	
		Interval [dot]: H =	Set the number of lines in the horizontal direction.
		Interval [dot]: V =	Set the number of lines in the vertical direction.
(4)	Line Width [dot]	The line width is set here.	
		Line Width [dot]: H =	Set the number of lines in the horizontal direction.
		Line Width [dot]: V =	Set the number of lines in the vertical direction.

6.10.4 Dot patterns

The dot pattern settings are described below.





















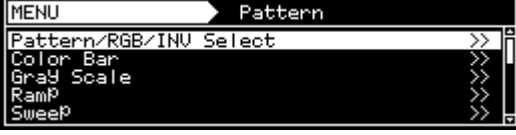

<p>(1) Select Program Edit using  →  or  INC  DEC, and then press .</p>	 <pre> MENU Program Edit Program Name : ▶EIA1920x1080Pa60 Timing (TIM) >>> Output (TIM) >>> Audio (TIM) >>> Pattern (PAT) >>> </pre>
<p>(2) Select Pattern (PAT) using  or  INC  DEC, and then press .</p>	 <pre> MENU Pattern Pattern/RGB/INV Select >>> Color Bar >>> Gray Scale >>> Ramp >>> Sweep >>> </pre>
<p>(3) Select Pattern/RGB/INV select using  or  INC  DEC, and then press .</p>	 <pre> MENU Pattern/RGB/INV Select [] Color Bar [] Gray Scale [] Ramp [] Sweep [] Monoscope </pre>
<p>(4) Select Dot using  or  INC  DEC, and then press .</p>	 <pre> MENU Pattern/RGB/INV Select [] Cross Hatch [x] Dot [] 0 [] X [] + </pre>
<p>(5) Press .</p>	 <pre> MENU Pattern Pattern/RGB/INV Select >>> Color Bar >>> Gray Scale >>> Ramp >>> Sweep >>> </pre>
<p>(6) Select <input type="checkbox"/> x [ABC] using  or  INC  DEC, and then press .</p>	 <pre> MENU DX[ABC] Color >>> Character >>> Cross Hatch >>> Dot >>> Circle >>> </pre>
<p>(7) Select Dot using  or  INC  DEC, and then press .</p>	 <pre> MENU Dot Format (0/1): ▶from Center Input Mode (0/1): Number Of Lines Number Of Lines : H= 25 U= 25 Size [dot]: 1 Shape (0/1): Square </pre>
<p>(8) <Setting the items> Select the items using  or  INC  DEC, and then press .</p> <p><Setting the parameters> Select the parameters using  or  INC  DEC, and then press .</p> <p>Alternatively: Select the parameters using the number keys  to , and then press .</p>	<p>For further details, refer to <Table of dot setting items> below.</p>



















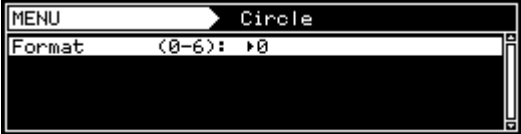

<Table of dot setting items>

(1)	Format (0-2)	The origin point of the pattern drawing is set here.	
		0	From Center The pattern is drawn using the screen center as the origin point.
		1	From Top-Left The pattern is drawn using the top left of the screen as the origin point.
(2)	InputMode (0/1)	The input mode is selected here.	
		0	Number Of Line This sets the number of lines to be displayed on the screen.
		1	Interval (dot) This sets the interval between the dots.
(3)-a	When Number of Lines has been selected as the Input Mode setting	The number of lines to be displayed on the screen is set here.	
		Number Of Lines: H =	Set the number of lines in the horizontal direction.
		Number Of Lines: V =	Set the number of lines in the vertical direction.
(4)-b	When Interval (dot) has been selected as the Input Mode setting	The interval between the blocks is set here.	
		Interval [dot]: H =	Set the number of lines in the horizontal direction.
		Interval [dot]: V =	Set the number of lines in the vertical direction.
(5)	Size [dot]	The size is set here. Setting range: 1 to 15 [Dot]	
(6)	Shape	The shape is set here.	
		0	Circle The dots are drawn in the form of circles.
		1	Square The dots are drawn in the form of squares.

6.10.5 Circle patterns

The circle pattern settings are described below.

(1)	<p>Select Program Edit using  →  or  , and then press .</p>	
(2)	<p>Select Pattern (PAT) using  or  , and then press .</p>	
(3)	<p>Select Pattern/RGB/INV select using  or  , and then press .</p>	
(4)	<p>Select Circle using  or  , and then press .</p>	
(5)	<p>Press .</p>	

(6)	<p>Select <input type="checkbox"/> x [ABC] using  or , and then press  , and then press .</p>	
(7)	<p>Select Circle using  or  , and then press .</p>	
(8)	<p><Setting the items></p> <p>Select Format using  or  , and then press .</p>	<p>Select the shapes of the circles from the options below.</p> <p>Format 0</p> <ul style="list-style-type: none"> • Single circle • Center: 1/2H, 1/2V • Radius: 1/3V
	<p><Setting the parameters></p> <p>Select the parameters using  or , and then press  , and then press .</p>	<p>Format 1</p> <ul style="list-style-type: none"> • Concentric circles 1 • Center: 1/2H, 1/2V • Radius (from the center): 1/6V, 1/3V, 1/2V, 1/2H
	<p>Alternatively:</p> <p>Select the parameters using the number keys</p>	<p>Format 2</p> <ul style="list-style-type: none"> • Format 1 + (circles with radius 1/6V x 4)
	<p>( to ), and then press .</p>	<p>Format 3</p> <ul style="list-style-type: none"> • Concentric circles 2 • Center: 1/2H, 1/2V • Radius (from the center): One circle added inside the 1/6V, 1/3V and 1/2 circles, 1/2 radius added
		<p>Format 4</p> <ul style="list-style-type: none"> • Consecutive circles with radius 1/6V • Top/bottom and left/right symmetry with center (1/2H, 1/2V) as the reference
		<p>Format 5</p> <ul style="list-style-type: none"> • Single filled-in circle • Center: 1/2H, 1/2V • Radius: 1/3V <p>Format 6</p> <ul style="list-style-type: none"> • Filled-in circles with radius 1/6V x 5

0

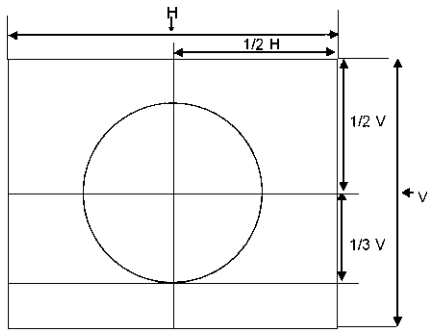

1

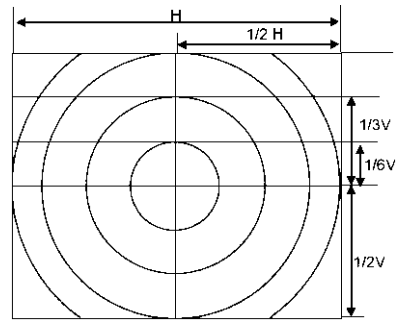

2

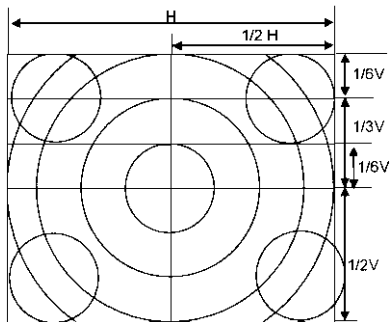

3

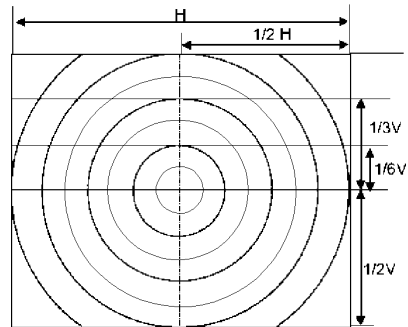

4

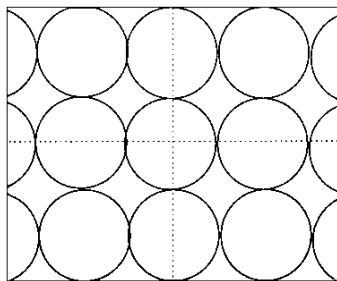

5

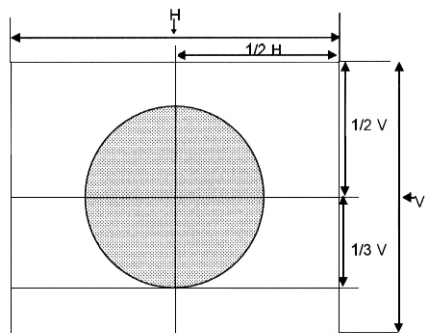

6

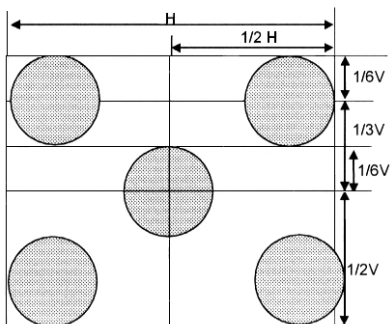





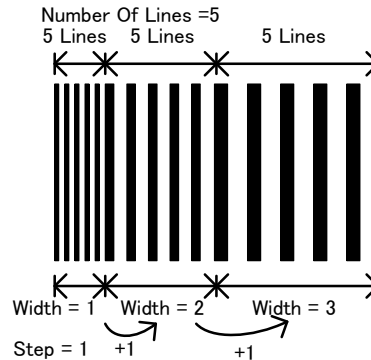





6.10.6 Burst patterns

In burst patterns, the line width increases gradually.



The burst pattern settings are described below.

(1)	Select Program Edit using or , and then press .	
(2)	Select Pattern (PAT) using or , and then press .	
(3)	Select Pattern/RGB/INV select using or , and then press .	
(4)	Select Burst using or , and then press .	
(5)	Press .	
(6)	Select <input type="checkbox"/> x [ABC] using or , and then press .	
(7)	Select Burst using or , and then press .	

(8)	<p><Setting the items></p> <p>Select the items using  or  ,</p> <p>and then press .</p>	For further details, refer to <Table of burst setting items> below.
	<p><Setting the parameters></p> <p>Select the parameters using  or </p> <p>, and then press .</p> <p>Alternatively:</p> <p>Select the parameters using the number keys</p> <p> to , and then press .</p>	

<Table of burst setting items>

(1)	Format (0-2)	The origin point of the pattern drawing is set here.		
		0	L->R	The line width increases from left to right.
		1	L<-R	The line width increases from right to left.
		2	L<-C->R	The line width increases from the center to the left edge and from the center to the right edge.
		3	L->C<-R	The line width increases from the left edge to the center and from the right edge to the center.
		4	T->B	The line width increases from top to bottom.
		5	T<-B	The line width increases from bottom to top.
		6	T<-C->B	The line width increases from the center to the top edge and from the center to the bottom edge.
7	T->C<-B	The line width increases from the top edge to the center and from the bottom edge to the center.		
(2)	Number of Line	The number of lines set here is repeatedly drawn with the same thickness. After the set number of lines has been drawn, the thickness is increased by an amount equivalent to the Step setting , and this is repeated. Setting range: 1 to 99		
(3)	Step	The step is set here. Setting range: 0 to 99 [dot]		

6.11 Window patterns



Mono-color rectangles can be displayed as the window patterns.

The window patterns can also be used to check moving images using the action function described later (refer to the action settings).

6.11.1 Types of window patterns



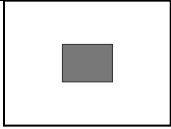
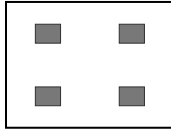
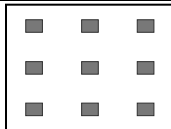
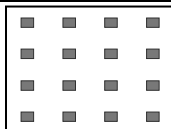
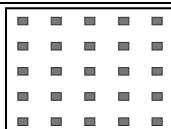
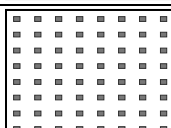

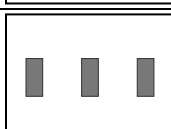
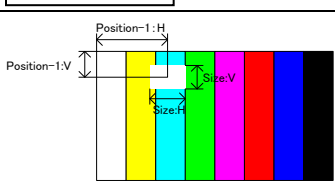
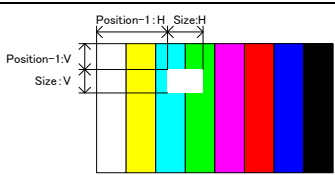

























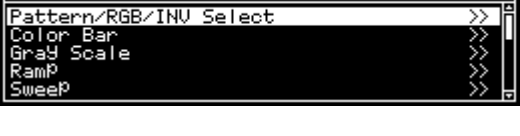







When window has been selected using the pattern key, for instance, window patterns can be selected from among the types listed below.

For further details on pattern selection, refer to “2.1.3 Selecting the pattern data.”

0	1 Window	1 window displayed	
1	4 Window	4 windows displayed	
2	9 Window	9 windows displayed	
3	16 Window	16 windows displayed	
4	25 Window	25 windows displayed	
5	64 Window	64 windows displayed	
6	3 Window In V Row	3 windows in a vertical row displayed	
7	3 Window In H Row	3 windows in a horizontal row displayed	
8	User Pos Center	Window displayed at the position of the user's choice * The coordinates of the window center are specified as the origin point of the display.	
9	User Pos Corner	Window displayed at the position of the user's choice * The coordinates of the top left of the window are specified as the origin point of the display.	

6.11.2 Window pattern settings

The types of window patterns can be selected using the procedure below.

(1)	<p>Select Program Edit using  or  , and then press .</p>	 <pre> MENU Program Edit Program Name : ▶EIA1920x1080P60 Timing (TIM) >> Output (TIM) >> Audio (TIM) >> Pattern (PAT) >> </pre>
(2)	<p>Select Pattern (PAT) using  or  , and then press .</p>	 <pre> MENU Pattern Pattern/RGB/INU Select >> Color Bar >> Gray Scale >> Ramp >> Sweep >> </pre>
(3)	<p>Select Pattern/RGB/INV select using  or  , and then press .</p>	 <pre> MENU Pattern/RGB/INU Select [] Color Bar [] Gray Scale [] Ramp [] Sweep [] Monoscope </pre>
(4)	<p>Select Window using  or  , and then press .</p>	 <pre> MENU Pattern/RGB/INU Select [✓] Window [] Cursor [] Name/List [✓] R/Pr [✓] G/V </pre>
(5)	<p>Press .</p>	 <pre> MENU Pattern Pattern/RGB/INU Select >> Color Bar >> Gray Scale >> Ramp >> Sweep >> </pre>
(6)	<p>Select Window using  or  , and then press .</p>	 <pre> MENU Window : 8bit Format (0-9): ▶1 Window Input Mode (0/1): % Size [%]: H= 20.0 U= 20.0 Position-1 [%]: H= 0.0 U= 0.0 Position-2 [%]: H= 0.0 U= 0.0 </pre>
(7)	<p><Selecting the items></p> <p>Select the items using  or  , and then press .</p> <p><Setting the parameters></p> <p>Select the parameters using  or  , and then press .</p> <p>Alternatively: Select the parameters using the number keys   ( to ), and then press .</p>	<p>For further details on the parameters, refer to <Table of window setting items> below.</p>

<Table of window setting items>

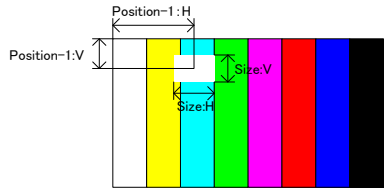
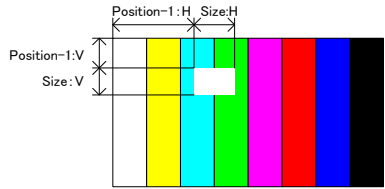
(1)	Format (0-9)	The window display format is set here.		
		0	1 Window	One window is displayed at the center of the screen.
		1	4 Window	The screen is divided into four areas, and each of the four windows is displayed in the center of its respective area. The window size is set using the area divided into the four areas as 100%.
		2	9 Window	The screen is divided into four areas, and each of the nine windows is displayed in the center of its respective area.
		3	16 Window	The screen is divided into four areas, and each of the sixteen windows is displayed in the center of its respective area.
		4	25 Window	The screen is divided into four areas, and each of the thirty-two windows is displayed in the center of its respective area.
		5	64 Window	The screen is divided into four areas, and each of the sixty-four windows is displayed in the center of its respective area.
		6	3 Window In V Row	The screen is divided vertically into three areas, and each of the three windows is displayed in the center of its respective area.
		7	3 Window In H Row	The screen is divided horizontally into three areas, and each of the three windows is displayed in the center of its respective area.
		8	User Pos Center	The window can be displayed at any position. The coordinates of the window center are specified as the origin point of the window display. 
9	User Pos Corner	The window can be displayed at any position. The coordinates of the top left of the window are specified as the origin point of the window display. 		
(2)	Input Mode	The input mode for the window size and display position is specified here.		
		0	%	The size and position are set as a percentage of the entire screen.
		1	dot	The size and position are set in 1-dot increments.
(3)	Size	The window size is set here. The setting procedure differs depending on the Input Mode setting .		

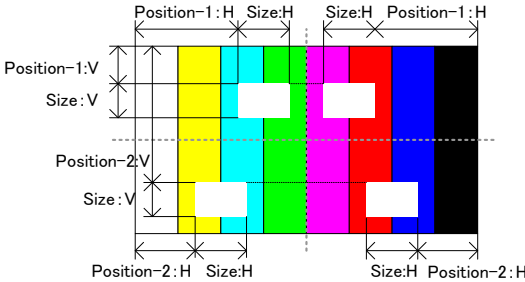
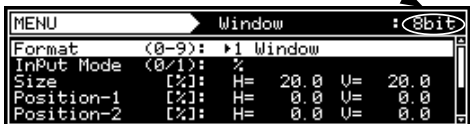
(4)	<p>Position-1 Position-2</p>	<p>Specify the coordinates of the window when format 8 (User Pos Center) or format 9 (User Pos Corner) has been selected. When Position-2 is set, the window is displayed at the reverse mirror positions of Position-1 and Position-2. In other words, when Position-2 is set, four windows are displayed at the same time.</p>  <p>H = The window center position or horizontal direction of its start position is set here.</p> <p>V = The window center position or vertical direction of its start position is set here.</p>																				
(5)	<p>Color R G B</p>	<p>The window colors and level are set here.</p> <p style="text-align: center;">Bit Length</p>  <p>The setting range differs depending on the color depth.</p> <table border="1" data-bbox="1117 716 1380 1075"> <thead> <tr> <th colspan="2">Setting ranges by color depth</th> </tr> </thead> <tbody> <tr> <td>8 BIT</td> <td>0 to 255</td> </tr> <tr> <td>9 BIT</td> <td>0 to 511</td> </tr> <tr> <td>10 BIT</td> <td>0 to 1023</td> </tr> <tr> <td>11 BIT</td> <td>0 to 2047</td> </tr> <tr> <td>12 BIT</td> <td>0 to 4095</td> </tr> <tr> <td>13 BIT</td> <td>0 to 8191</td> </tr> <tr> <td>14 BIT</td> <td>0 to 16383</td> </tr> <tr> <td>15 BIT</td> <td>0 to 32767</td> </tr> <tr> <td>16 BIT</td> <td>0 to 65535</td> </tr> </tbody> </table>	Setting ranges by color depth		8 BIT	0 to 255	9 BIT	0 to 511	10 BIT	0 to 1023	11 BIT	0 to 2047	12 BIT	0 to 4095	13 BIT	0 to 8191	14 BIT	0 to 16383	15 BIT	0 to 32767	16 BIT	0 to 65535
Setting ranges by color depth																						
8 BIT	0 to 255																					
9 BIT	0 to 511																					
10 BIT	0 to 1023																					
11 BIT	0 to 2047																					
12 BIT	0 to 4095																					
13 BIT	0 to 8191																					
14 BIT	0 to 16383																					
15 BIT	0 to 32767																					
16 BIT	0 to 65535																					

6.12 Cursor patterns





































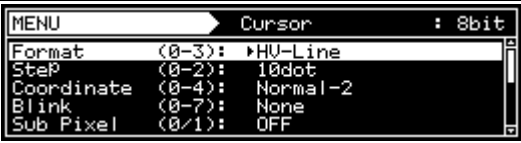

A cursor can be displayed on screens which show pattern displays.

The cursor can be moved to any point, and its position on the screen can be displayed.

6.12.1 Cursor settings

The cursor can be selected by following the operation procedure below.

For further details on pattern selection, refer to “2.1.3 Selecting the pattern data.”

<p>(1) Select Program Edit using  →  or  INC  DEC, and then press .</p>	
<p>(2) Select Pattern (PAT) using  or  INC  DEC, and then press .</p>	
<p>(3) Select Pattern/RGB/INU select using  or  INC  DEC, and then press .</p>	
<p>(4) Select Cursor using  or  INC  DEC, and then press .</p>	
<p>(5) Press .</p>	
<p>(6) Select Cursor using  or  INC  DEC, and then press .</p>	
<p>(7) <Selecting the items> Select the items using  or  INC  DEC, and then press .</p> <p><Setting the parameters> Select the parameters using  or  INC  DEC, and then press .</p> <p>Alternatively: Select the parameters using the number keys  to , and then press .</p>	<p>For further details on the parameters, refer to <Table of cursor setting items> below.</p>

<Example of what is displayed>

Coordinates of target cursor (#1 = cursor 1, #2 = cursor 2 when Cursor 2 is ON)

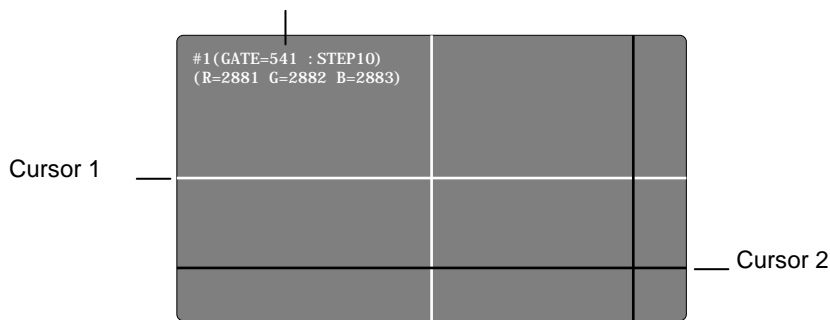

<Table of cursor setting items>

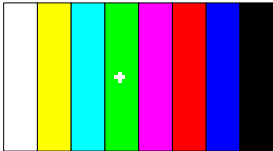
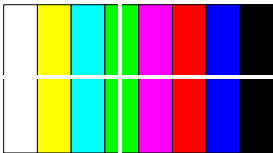
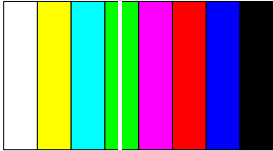
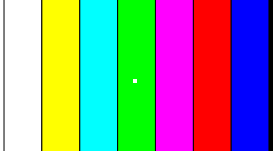
(1)	Format (0-3)	The shape of the cursor is set here.	
		0	5 x 5 Cross The cursor is displayed as a 5-pixel x 5-pixel cross. 
		1	HV-Line The cursor is displayed as a cross whose horizontal and vertical dimensions extend to the edges of the screen. 
		2	V-Line The cursor is displayed as a vertical line. 
		3	Dot The cursor is displayed as a 1-pixel x 1-pixel. 
(2)	Step	The amount of cursor movement when the cursor is to be moved is set here.	
		0 to 2	1 dot/10 dot/100 dot
(3)	Coordinate	The coordinate display method is set here.	
		0	OFF No coordinates are displayed.
		1	Normal-1 The horizontal and vertical coordinates and step are displayed in 1-pixel increments.
		2	Normal-2 The horizontal and vertical coordinates are displayed in sub-pixel increments, and the step is displayed in 1-pixel increments.
		3	Reverse-1 Normal-1 is inverted at the top and bottom, and displayed.
		4	Reverse-2 Normal-2 is inverted at the top and bottom, and displayed.
(4)	Blink	Whether the cursor is to blink and the blink interval are set here.	

		0	None	The cursor does not blink.																				
		1 to 7	1 V /2 V /4 V /8 V /16 V /32 V /64 V	The cursor blinks for each 1 V (vertical sync period) to 64 V and then goes off, and this is repeated.																				
(5)	Sub Pixel	Whether the cursor is to be moved in 1-pixel increments or sub-pixel increments is set here. [Operation in sub-pixel increments]																						
		0	OFF	The cursor is moved in 1-pixel increments.																				
		1	ON	The cursor is moved in sub-pixel increments.																				
(6)	Overlay	Whether the cursor is to be displayed on top of the test pattern or on top of the background color set using the Color Back R G B item is set here.																						
		0	OFF	The cursor is displayed on top of the background color set by the Color Back R G B item.																				
		1	ON	The cursor is displayed on top of the test pattern.																				
(7)	Intersection	The shape of the intersection is set here.																						
		0	Normal	The intersection is filled in as a cross.																				
		1	Space	The cursor is not displayed in the pixels of the intersection and sub-pixels below it, but the original background is displayed instead.																				
(8)	Cursor 2	The display of the second cursor (cursor 2) is set here.																						
		0	OFF	The cursor is not displayed.																				
		1	ON	The cursor is displayed.																				
(9)	Color Cursor 1 R G B	The cursor 1 color and level are set here. The setting range differs depending on the color depth.		<table border="1"> <thead> <tr> <th colspan="2">Setting ranges by color depth</th> </tr> </thead> <tbody> <tr> <td>8 BIT</td> <td>0 to 255</td> </tr> <tr> <td>9 BIT</td> <td>0 to 511</td> </tr> <tr> <td>10 BIT</td> <td>0 to 1023</td> </tr> <tr> <td>11 BIT</td> <td>0 to 2047</td> </tr> <tr> <td>12 BIT</td> <td>0 to 4095</td> </tr> <tr> <td>13 BIT</td> <td>0 to 8191</td> </tr> <tr> <td>14 BIT</td> <td>0 to 16383</td> </tr> <tr> <td>15 BIT</td> <td>0 to 32767</td> </tr> <tr> <td>16 BIT</td> <td>0 to 65535</td> </tr> </tbody> </table>	Setting ranges by color depth		8 BIT	0 to 255	9 BIT	0 to 511	10 BIT	0 to 1023	11 BIT	0 to 2047	12 BIT	0 to 4095	13 BIT	0 to 8191	14 BIT	0 to 16383	15 BIT	0 to 32767	16 BIT	0 to 65535
Setting ranges by color depth																								
8 BIT	0 to 255																							
9 BIT	0 to 511																							
10 BIT	0 to 1023																							
11 BIT	0 to 2047																							
12 BIT	0 to 4095																							
13 BIT	0 to 8191																							
14 BIT	0 to 16383																							
15 BIT	0 to 32767																							
16 BIT	0 to 65535																							
(10)	Color Cursor 2 R, G, B	The cursor 2 color and level are set here. The setting procedure is the same as for the Color Cursor 1 R G B item.																						
(11)	Color Back R G B	The background color and level are set here. However, when On has been selected as the Overlay item setting, the test pattern becomes the background so that this setting is canceled. The setting procedure is the same as for the Color Cursor 1 R G B item.																						

6.12.2 Cursor operations

The cursor operations which can be performed include moving the cursor and changing the cursor level.

Operation screen display

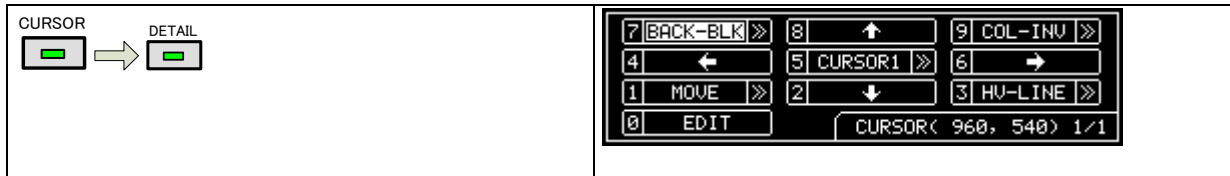

Moving the cursor

<p>(1) Select MOVE using <input type="button" value="1"/>.</p> <p>(When Cursor 2 is ON)</p> <p>Select CURSOR1 or CURSOR2 using <input type="button" value="5/B"/>.</p>	
<p>(2) When the number keys are used</p> <p>4/A ←, 6/C →, 2 ↓, 8/E ↑</p> <p><input type="button" value="4"/>, <input type="button" value="6"/>, <input type="button" value="2"/>, <input type="button" value="8"/></p>	<p>4 The cursor moves toward the left.</p> <p>6 The cursor moves toward the right.</p> <p>2 The cursor moves downward.</p> <p>8 The cursor moves upward.</p>
<p>(3) When the jog dial is used</p>	<p>When <input type="button" value="4/A"/> or <input type="button" value="6/C"/> is pressed and the jog dial is turned, the cursor moves to the left or right.</p> <p>When <input type="button" value="2"/> or <input type="button" value="8/E"/> is pressed and the jog dial is turned, the cursor moves downward or upward.</p>
<p>(4) When the USB mouse is used (Refer to "1.4.6 Names of connectors and their applications.")</p>	<p>The cursor moves in line with the mouse movements. Use the right button to switch between CURSOR1 and CURSOR2.</p>



Changing the cursor level

These steps change the **Color Cursor 1 R, G, B** and **Color Cursor 2 R, G, B** settings.

<p>(1) Select LEVEL using <input type="button" value="1"/>.</p> <p>(When Cursor 2 is ON)</p> <p>Select CURSOR1 or CURSOR2 using <input type="button" value="5/B"/>.</p>	
<p>(2) (When the number keys are used)</p> <p>2 ↓, 8/E ↑</p> <p><input type="button" value="2"/>, <input type="button" value="8"/></p>	<p>2 The level is decremented.</p> <p>8 The level is incremented.</p>
<p>(3) (When the jog dial is used)</p>	<p>When the dial is turned counterclockwise The level is decremented.</p> <p>When the dial is turned clockwise The level is incremented.</p>

Changing the background level

These steps change the **Color Back R, G, B** settings.

(1)	Select LEVEL-BK using <input type="text"/> . Select BACK-DEF using <input type="text"/> .		
(2)	(When the number keys are used) <input type="text"/> (2 ↓), <input type="text"/> (8/E ⇐)	2	The level is decremented.
		8	The level is incremented.
(3)	(When the jog dial is used) 	When the dial is turned counter-clockwise	The level is decremented.
		When the dial is turned clockwise	The level is incremented.

Changing the cursor shape

These steps change the **Format** setting.

<input type="text"/> (3 ↻)	5x5CROSS	Cross consisting of 5 × 5 pixels
	HV-LINE	Cross which covers the entire screen
	V-LINE	Vertical line
	DOT	1 × 1 pixel

Changing the background color

<input type="text"/> (7/D ↻)	BACK-DEF	Color Back R, G, B settings
	BACK-W	White
	BACK-R	Red
	BACK-G	Green
	BACK-B	Blue
	BACK-BLK	Black

Inverting the cursor color

<input type="text"/> (9/F ↻)	COL-DEF	Normal
	COL-INV	Inverted

6.13 Name/List

















Information such as the setting data and execution results as well as the images (number of colors restricted) are contained in the Name/List patterns, and they can be superimposed onto other patterns.























<Name/List types>

NAME/LIST 	NAME	Program name display	For details, refer to "6.13.2 Name."
	EDID	EDID setting data display	For further details, refer to "6.13.3 EDID."
	DDC/CI	DDC-CI setting data display	For further details, refer to "6.13.4 DDC/CI."
	HDCP	HDCP authentication screen display.	For further details, refer to "6.13.5 HDCP (High-bandwidth Digital Content Protection)."
	CEC	CEC setting data display	For further details, refer to "4.2.4 CEC function."
	HDMI	HMDI setting data display	For further details, refer to "6.13.6 HDMI list."
	TIMING	Timing data (parameter, etc.) display	For further details, refer to "6.13.7 Timing data list."
	IMAGE	Image pattern list display	For further details, refer to "6.13.8 Image pattern list."
	OPT-USER	User optional pattern list display	For further details, refer to "6.13.9 OPT-USER pattern list."
	DP	Display port setting information display (link rate, number of lanes, link training results, DPCD)	For details, refer to "4.12.3 Displaying the DisplayPort setting information."
	SUBTITLE	Display of images to be used for the subtitles created by the user	For details, refer to "6.13.10 Subtitle."
	HDMI ARC	Audio Return Channel data display	For details, refer to "4.2.11 Audio Return Channel."
	HDMI HEC	HDMI Ethernet Channel data display	For details, refer to "4.2.12 HDMI Ethernet Channel".

6.13.1 Name/List display











































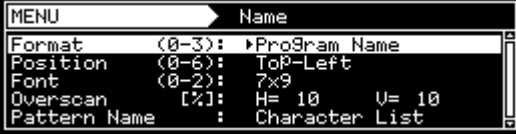

The Name/List functions can be selected by the operations described below.

(1)	<p>Select Program Edit using   </p> <p>or  , and then press .</p>	 <pre> MENU Program Edit Program Name : ▶EIA1920x1080P@60 Timing (TIM) >>> Output (TIM) >>> Audio (TIM) >>> Pattern (PAT) >>> </pre>
(2)	<p>Select Pattern (PAT) using  or </p> <p>, and then press .</p>	 <pre> MENU Pattern Pattern/RGB/INU Select >>> Color Bar >>> Gray Scale >>> Ramp >>> Sweep >>> </pre>
(3)	<p>Select Pattern/RGB/INV select using  or  </p> <p>.</p>	 <pre> MENU Pattern/RGB/INU Select Color Bar [] Gray Scale [] Ramp [] Sweep [] Monoscope [] </pre>

(4)	Select Name/List using  or   , and then press  .																																														
(5)	Press  .																																														
(6)	Select Name/List using  or   , and then press  .																																														
(7)	<Selecting the items> Select the items using  or   , and then press  .	The pattern to be displayed by Type is specified here. Some patterns have detailed setting items. <Type> <table border="1" data-bbox="863 790 1497 1688"> <tbody> <tr> <td data-bbox="863 790 890 851">0</td> <td data-bbox="890 790 1066 851">NAME</td> <td data-bbox="1066 790 1497 851">The names of the programs are displayed.</td> </tr> <tr> <td data-bbox="863 851 890 911">1</td> <td data-bbox="890 851 1066 911">Subtitle</td> <td data-bbox="1066 851 1497 911">The images to be used for the subtitles created by the user are displayed.</td> </tr> <tr> <td data-bbox="863 911 890 949">2</td> <td data-bbox="890 911 1066 949">EDID</td> <td data-bbox="1066 911 1497 949">The EDID is displayed as text.</td> </tr> <tr> <td data-bbox="863 949 890 1010">3</td> <td data-bbox="890 949 1066 1010">EDID (HEX)</td> <td data-bbox="1066 949 1497 1010">The EDID is displayed in the hexadecimal (HEX) format.</td> </tr> <tr> <td data-bbox="863 1010 890 1048">4</td> <td data-bbox="890 1010 1066 1048">DDC/CI</td> <td data-bbox="1066 1010 1497 1048">DDC/CI is used.</td> </tr> <tr> <td data-bbox="863 1048 890 1108">5</td> <td data-bbox="890 1048 1066 1108">HDCP</td> <td data-bbox="1066 1048 1497 1108">The HDCP authentication screen is displayed.</td> </tr> <tr> <td data-bbox="863 1108 890 1169">6</td> <td data-bbox="890 1108 1066 1169">Timing</td> <td data-bbox="1066 1108 1497 1169">A list of the timing data being output is displayed.</td> </tr> <tr> <td data-bbox="863 1169 890 1229">7</td> <td data-bbox="890 1169 1066 1229">Image</td> <td data-bbox="1066 1169 1497 1229">Information of the image patterns registered in the internal memory or on the CF card is displayed.</td> </tr> <tr> <td data-bbox="863 1229 890 1290">8</td> <td data-bbox="890 1229 1066 1290">OPT-USER</td> <td data-bbox="1066 1229 1497 1290">The names and sizes of the user optional patterns registered in the internal memory or on the CF card is displayed.</td> </tr> <tr> <td data-bbox="863 1290 890 1328">9</td> <td data-bbox="890 1290 1066 1328">CEC</td> <td data-bbox="1066 1290 1497 1328">The CEC execution list is displayed.</td> </tr> <tr> <td data-bbox="863 1328 890 1388">A</td> <td data-bbox="890 1328 1066 1388">HDMI ARC</td> <td data-bbox="1066 1328 1497 1388">Audio Return Channel data is displayed.</td> </tr> <tr> <td data-bbox="863 1388 890 1449">B</td> <td data-bbox="890 1388 1066 1449">HDMI HEC</td> <td data-bbox="1066 1388 1497 1449">HDMI Ethernet Channel data is displayed.</td> </tr> <tr> <td data-bbox="863 1449 890 1509">C</td> <td data-bbox="890 1449 1066 1509">HDMI</td> <td data-bbox="1066 1449 1497 1509">A list of the HDMI-related data is displayed.</td> </tr> <tr> <td data-bbox="863 1509 890 1547">D</td> <td data-bbox="890 1509 1066 1547">DP</td> <td data-bbox="1066 1509 1497 1547">DPCD is displayed.</td> </tr> <tr> <td data-bbox="863 1547 890 1608">E</td> <td data-bbox="890 1547 1066 1608">DP (HEX)</td> <td data-bbox="1066 1547 1497 1608">DPCD is displayed in the hexadecimal (HEX) format.</td> </tr> </tbody> </table>	0	NAME	The names of the programs are displayed.	1	Subtitle	The images to be used for the subtitles created by the user are displayed.	2	EDID	The EDID is displayed as text.	3	EDID (HEX)	The EDID is displayed in the hexadecimal (HEX) format.	4	DDC/CI	DDC/CI is used.	5	HDCP	The HDCP authentication screen is displayed.	6	Timing	A list of the timing data being output is displayed.	7	Image	Information of the image patterns registered in the internal memory or on the CF card is displayed.	8	OPT-USER	The names and sizes of the user optional patterns registered in the internal memory or on the CF card is displayed.	9	CEC	The CEC execution list is displayed.	A	HDMI ARC	Audio Return Channel data is displayed.	B	HDMI HEC	HDMI Ethernet Channel data is displayed.	C	HDMI	A list of the HDMI-related data is displayed.	D	DP	DPCD is displayed.	E	DP (HEX)	DPCD is displayed in the hexadecimal (HEX) format.
	0		NAME	The names of the programs are displayed.																																											
1	Subtitle	The images to be used for the subtitles created by the user are displayed.																																													
2	EDID	The EDID is displayed as text.																																													
3	EDID (HEX)	The EDID is displayed in the hexadecimal (HEX) format.																																													
4	DDC/CI	DDC/CI is used.																																													
5	HDCP	The HDCP authentication screen is displayed.																																													
6	Timing	A list of the timing data being output is displayed.																																													
7	Image	Information of the image patterns registered in the internal memory or on the CF card is displayed.																																													
8	OPT-USER	The names and sizes of the user optional patterns registered in the internal memory or on the CF card is displayed.																																													
9	CEC	The CEC execution list is displayed.																																													
A	HDMI ARC	Audio Return Channel data is displayed.																																													
B	HDMI HEC	HDMI Ethernet Channel data is displayed.																																													
C	HDMI	A list of the HDMI-related data is displayed.																																													
D	DP	DPCD is displayed.																																													
E	DP (HEX)	DPCD is displayed in the hexadecimal (HEX) format.																																													
<Setting the parameters> Select the parameters using  or   , and then press  . Alternatively: Select the parameters using the number keys ( to ) , and then press  .																																															

6.13.2 Name

The display method can be set when Name has been selected as the Type setting.

<p>(1) Select Program Edit using  →  or  INC  DEC, and then press .</p>	 <pre> MENU Program Edit Program Name : ▶EIA1920x1080P60 Timing (TIM) Output (TIM) Audio (TIM) Pattern (PAT) </pre>
<p>(2) Select Pattern (PAT) using  or  INC  DEC, and then press .</p>	 <pre> MENU Pattern Pattern/RGB/INU Select Color Bar Gray Scale Ramp Sweep </pre>
<p>(3) Select Pattern/RGB/INV select using  or  INC  DEC, and then press .</p>	 <pre> MENU Pattern/RGB/INV Select Color Bar Gray Scale Ramp Sweep Monoscope </pre>
<p>(4) Select Name/List using  or  INC  DEC, and then press .</p>	 <pre> MENU Name/List Window Cursor Name/List R/Pr G/V </pre>
<p>(5) Press .</p>	 <pre> MENU Pattern Pattern/RGB/INU Select Color Bar Gray Scale Ramp Sweep </pre>
<p>(6) Select Name/List using  or  INC  DEC, and then press .</p>	 <pre> MENU Name/List Type (0-C): ▶NAME NAME Subtitle EDID DDC/CI </pre>
<p>(7) Select Name using  or  INC  DEC, and then press .</p>	 <pre> MENU Name Format (0-3): ▶Program Name Position (0-6): Top-Left Font (0-2): 7x9 Overscan [%]: H= 10 U= 10 Pattern Name : Character List </pre>
<p>(8) <Selecting the items> Select the items using  or  INC  DEC, and then press .</p> <p><Setting the parameters> Select the parameters using  or  INC  DEC, and then press .</p> <p>Alternatively: Select the parameters using the number keys  ( to ), and then press .</p>	<p>For further details, refer to <Table of name setting items> below.</p>











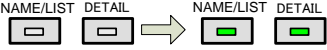





<Table of name setting items>

(1)	Format (0-3)	The display contents of Name are set here.		
		0	Program Name	The program names are displayed.
		1	Pattern Name	The pattern names are displayed.
		2	Program & Pattern Name	The program names and pattern names are displayed at the same time.
		3	Program Name, Freq	The program names and video timing signal frequencies are displayed at the same time.
(2)	Position	The display position of the name is set here.		
		0	Center	The name is displayed at the screen center.
		1	Top-Left	The name is displayed at the top left of the screen.
		2	Bottom-Left	The name is displayed at the bottom left of the screen.
		3	Top-Right	The name is displayed at the top right of the screen.
		4	Bottom-Right	The name is displayed at the bottom right of the screen.
		5	Top-Center	The name is displayed at the upper center of the screen.
		6	Bottom Center	The name is displayed at the lower center of the screen.
(3)	Font	The font size is set here.		
		0	5 × 7	5 × 7 is set as the font size.
		1	7 × 9	7 × 9 is set as the font size.
		2	16 × 16	16 × 16 is set as the font size.
(4)	Overscan [%]	The display position can be adjusted in such a way that the display is not hidden to simulate an overscanning monitor.		
		H =	Set the horizontal overscanning ratio.	
		V =	Set the vertical overscanning ratio.	
(5)	Pattern Name	The pattern names are edited here. For details on the editing procedure, refer to "2.3 Setting the names."		

6.13.3 EDID

The EDID of the connected display can be displayed on the screen.

a) EDID display method

(1)		
(2)	<p><Displaying the EDID></p> <p>Select EDID using  or  , and then press .</p> <p>Alternatively, select  for the GUI display format or  for the HEX display format.</p>	<p>The EDID is displayed as shown in the figure below.</p> 
(3)	<p><Selecting the pages></p> <p>Select  (previous page) or  (next page) using  or  , and then press .</p> <p>Alternatively, select the page using  (previous page) or  (next page).</p>	<p>When the display extends over several pages, it is divided up on the fluorescent display tube, and shown. (Switch from one page to another to display all the information.)</p>

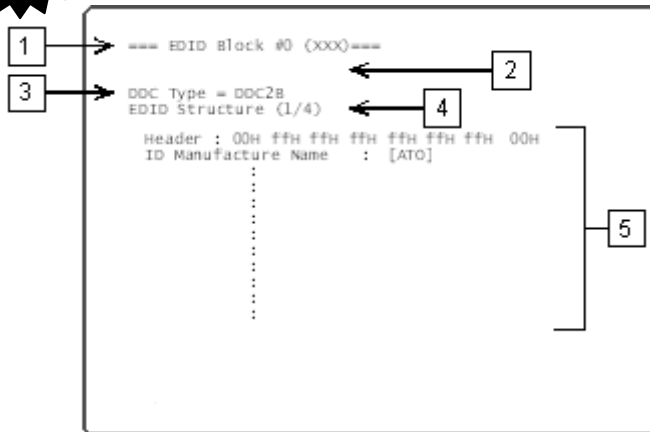

With the GUI display format

- 1) Block number of EDID
- 2) Error display when an error has occurred
- 3) DDC type
- 4) EDID block now displayed
- 5) Content of EDID

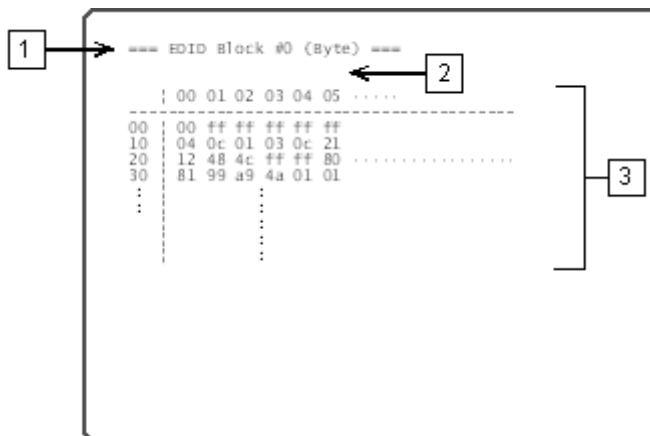

With the HEX display format











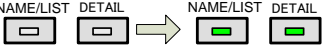

- 1) Block number of EDID
- 2) Error display when an error has occurred
- 3) Content of EDID



The maximum number of blocks read for EDID is 8 (one basic block + 7 expanded blocks). (When HDMI is selected)

b) Port selection method

The EDID is displayed by only one video interface at a time, and it is necessary to set the video interface which is to display the EDID.











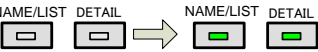

(1)	 <p>Establish the state in which EDID or EDID (HEX) is selected.</p>																																								
(2)	<p>Select EDIT using  or  , and then press .</p> <p>Alternatively, select EDIT using .</p>																																								
(3)	<p><Selecting the port></p> <p>Select the port using  or  , and then press .</p>	<p>Select the video interface which is to display the EDID. (Depending on the unit configuration, not all the following parameters will be displayed.)</p> <table border="1" data-bbox="743 741 1374 1279"> <tr> <td>0</td> <td>DVI1</td> <td>Channel 1 of the DVI unit is selected.</td> </tr> <tr> <td>1</td> <td>DVI2</td> <td>Channel 2 of the DVI unit is selected.</td> </tr> <tr> <td>2</td> <td>iTMDS1</td> <td>Channel 1 of the iTMDS unit is selected.</td> </tr> <tr> <td>3</td> <td>iTMDS2</td> <td>Channel 2 of the iTMDS unit is selected.</td> </tr> <tr> <td>4</td> <td>iTMDS-Quad 1</td> <td>Channel 1 of the iTMDS Quad unit is selected.</td> </tr> <tr> <td>5</td> <td>iTMDS-Quad 3</td> <td>Channel 3 of the iTMDS Quad unit is selected.</td> </tr> <tr> <td>6</td> <td>HDMI1</td> <td>Channel 1 of the HDMI unit is selected.</td> </tr> <tr> <td>7</td> <td>HDMI2</td> <td>Channel 2 of the HDMI unit is selected.</td> </tr> <tr> <td>8</td> <td>DP1</td> <td>Channel 1 of the DPI unit is selected.</td> </tr> <tr> <td>9</td> <td>DP2</td> <td>Channel 2 of the DPI unit is selected.</td> </tr> <tr> <td>A</td> <td>PC-DVI</td> <td>DVI of the PC analog unit is selected.</td> </tr> <tr> <td>B</td> <td>PC-VGA</td> <td>VGA of the PC analog unit is selected.</td> </tr> <tr> <td>C</td> <td>TV-VGA/DVI</td> <td>VGA of the TV encoder unit is selected.</td> </tr> </table>	0	DVI1	Channel 1 of the DVI unit is selected.	1	DVI2	Channel 2 of the DVI unit is selected.	2	iTMDS1	Channel 1 of the iTMDS unit is selected.	3	iTMDS2	Channel 2 of the iTMDS unit is selected.	4	iTMDS-Quad 1	Channel 1 of the iTMDS Quad unit is selected.	5	iTMDS-Quad 3	Channel 3 of the iTMDS Quad unit is selected.	6	HDMI1	Channel 1 of the HDMI unit is selected.	7	HDMI2	Channel 2 of the HDMI unit is selected.	8	DP1	Channel 1 of the DPI unit is selected.	9	DP2	Channel 2 of the DPI unit is selected.	A	PC-DVI	DVI of the PC analog unit is selected.	B	PC-VGA	VGA of the PC analog unit is selected.	C	TV-VGA/DVI	VGA of the TV encoder unit is selected.
0	DVI1	Channel 1 of the DVI unit is selected.																																							
1	DVI2	Channel 2 of the DVI unit is selected.																																							
2	iTMDS1	Channel 1 of the iTMDS unit is selected.																																							
3	iTMDS2	Channel 2 of the iTMDS unit is selected.																																							
4	iTMDS-Quad 1	Channel 1 of the iTMDS Quad unit is selected.																																							
5	iTMDS-Quad 3	Channel 3 of the iTMDS Quad unit is selected.																																							
6	HDMI1	Channel 1 of the HDMI unit is selected.																																							
7	HDMI2	Channel 2 of the HDMI unit is selected.																																							
8	DP1	Channel 1 of the DPI unit is selected.																																							
9	DP2	Channel 2 of the DPI unit is selected.																																							
A	PC-DVI	DVI of the PC analog unit is selected.																																							
B	PC-VGA	VGA of the PC analog unit is selected.																																							
C	TV-VGA/DVI	VGA of the TV encoder unit is selected.																																							

6.13.4 DDC/CI





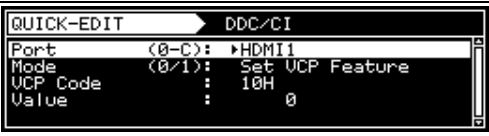

Using the DVI and VGA connectors, the DDC/CI commands can be sent and received, and shown on the display.

Two modes are available for DVI/CI: the **Get (Get VCP Feature)** mode in which the setting data is loaded from the information set in the display at the connection destination, and the **Set (Set VCP Feature)** mode in which the data of the user's choice is set.

<Setting DDC/CI>

<p>(1)</p> 	
<p>(2) <Selecting DDC/CI></p> <p>Select DDC/CI using  or  , and then press .</p>	
<p>(3) <Detailed setting: EDIT></p> <p>Select EDIT using  or  , and then press .</p> <p>Alternatively, select EDIT using .</p>	

<Re-executing DDC/CI>

<p>(1)</p> 	
<p>(2)</p> <p>Select RE-EXECUTE using  or , and then press .</p> <p>Alternatively, select RE-EXECUTE using .</p>	

<Table of DDC/CI setting items>

(1)	Port (0-C)	<p>The port for using DDC/CI is set here.</p> <table border="1"> <tr> <td>0</td> <td>DVI1</td> <td>DDC/CI is used by the DVI1 port.</td> </tr> <tr> <td>1</td> <td>DVI2</td> <td>DDC/CI is used by the DVI2 port.</td> </tr> <tr> <td>2</td> <td>iTMDS1</td> <td>DDC/CI is used by channel 1 of the iTMDS unit.</td> </tr> <tr> <td>3</td> <td>iTMDS2</td> <td>DDC/CI is used by channel 2 of the iTMDS unit.</td> </tr> <tr> <td>4</td> <td>iTMDS-Quad1</td> <td>DDC/CI is used by channel 1 of the iTMDS Quad unit.</td> </tr> <tr> <td>5</td> <td>iTMDS-Quad3</td> <td>DDC/CI is used by channel 3 of the iTMDS Quad unit.</td> </tr> <tr> <td>6</td> <td>HDMI1</td> <td>DDC/CI is used by the HDMI1 port.</td> </tr> <tr> <td>7</td> <td>HDMI2</td> <td>DDC/CI is used by the HDMI2 port.</td> </tr> <tr> <td>8</td> <td>DP1</td> <td>DDC/CI is used by the DisplayPort1.</td> </tr> <tr> <td>9</td> <td>DP2</td> <td>DDC/CI is used by the DisplayPort2.</td> </tr> <tr> <td>A</td> <td>PC-DVI</td> <td>DDC/CI is used by the DVI port of the PC analog unit.</td> </tr> <tr> <td>B</td> <td>PC-VGA</td> <td>DDC/CI is used by the VGA port of the PC analog unit.</td> </tr> <tr> <td>C</td> <td>TV-VGA/DVI</td> <td>DDC/CI is used by the DVI port of the TV encoder unit.</td> </tr> </table>	0	DVI1	DDC/CI is used by the DVI1 port.	1	DVI2	DDC/CI is used by the DVI2 port.	2	iTMDS1	DDC/CI is used by channel 1 of the iTMDS unit.	3	iTMDS2	DDC/CI is used by channel 2 of the iTMDS unit.	4	iTMDS-Quad1	DDC/CI is used by channel 1 of the iTMDS Quad unit.	5	iTMDS-Quad3	DDC/CI is used by channel 3 of the iTMDS Quad unit.	6	HDMI1	DDC/CI is used by the HDMI1 port.	7	HDMI2	DDC/CI is used by the HDMI2 port.	8	DP1	DDC/CI is used by the DisplayPort1.	9	DP2	DDC/CI is used by the DisplayPort2.	A	PC-DVI	DDC/CI is used by the DVI port of the PC analog unit.	B	PC-VGA	DDC/CI is used by the VGA port of the PC analog unit.	C	TV-VGA/DVI	DDC/CI is used by the DVI port of the TV encoder unit.
0	DVI1	DDC/CI is used by the DVI1 port.																																							
1	DVI2	DDC/CI is used by the DVI2 port.																																							
2	iTMDS1	DDC/CI is used by channel 1 of the iTMDS unit.																																							
3	iTMDS2	DDC/CI is used by channel 2 of the iTMDS unit.																																							
4	iTMDS-Quad1	DDC/CI is used by channel 1 of the iTMDS Quad unit.																																							
5	iTMDS-Quad3	DDC/CI is used by channel 3 of the iTMDS Quad unit.																																							
6	HDMI1	DDC/CI is used by the HDMI1 port.																																							
7	HDMI2	DDC/CI is used by the HDMI2 port.																																							
8	DP1	DDC/CI is used by the DisplayPort1.																																							
9	DP2	DDC/CI is used by the DisplayPort2.																																							
A	PC-DVI	DDC/CI is used by the DVI port of the PC analog unit.																																							
B	PC-VGA	DDC/CI is used by the VGA port of the PC analog unit.																																							
C	TV-VGA/DVI	DDC/CI is used by the DVI port of the TV encoder unit.																																							

(2)	Mode (0/1)	The operating mode is set here.	
		0	Get VCP Feature The status of the connection destination is checked.
		1	Set VCP Feature The control commands are sent to the connection destination.
(3)	VCP Code	00H-FFH	The VCP code is set.
(4)	Value	0-65535	A value is set only when Set VCP Feature has been selected as the Mode setting.

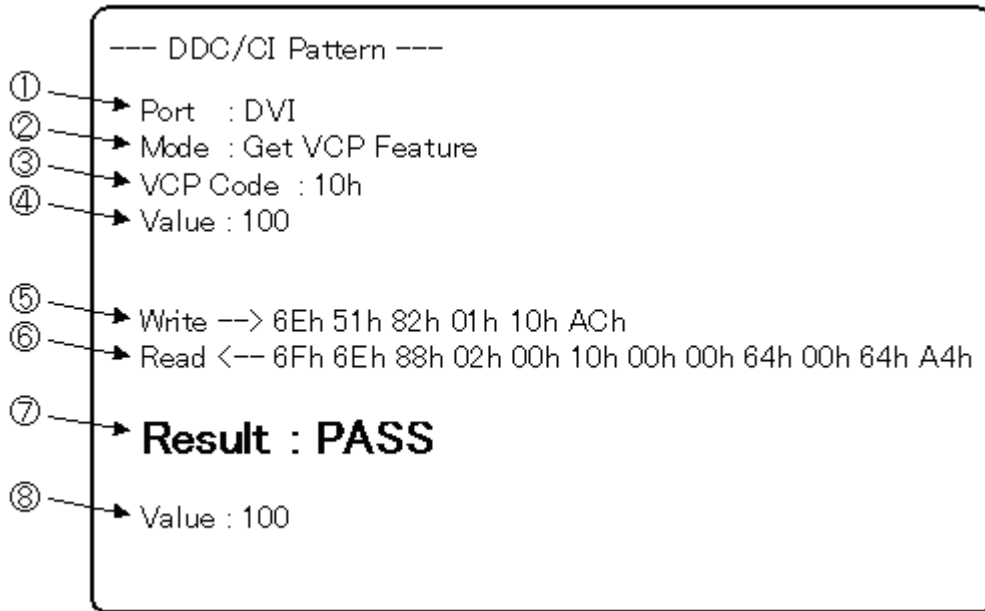







1	Port	Output port from which DDC/CI is transferred DVI or Dsub	Items to be set by the generator
2	Mode	DDC/CI transfer mode Get VCP Feature: The status of the connection destination is received. Set VCP Feature: Control commands are sent to the connection destination.	
3	VCP Code	Transfer command (set using the hexadecimal format)	
4	Value	(Displayed only when Set VCP Feature has been selected as the Mode setting.) Parameter value to be transferred from the generator to the connection destination	
5	Write	Data sent from the generator	Items which display the receiving or sending results
6	Read	Data received by the generator	
7	Result	Transfer result PASS: Data was transferred successfully. NG: Transfer failed.	
8	Value	(Displayed only when Get VCP Feature has been selected as the Mode setting.) Parameter value received by the VG-870/871/873/874 from the connection destination	

6.13.5 HDCP (High-bandwidth Digital Content Protection)

The HDCP authentication results can be shown on the display.

(For details on the HDCP settings and execution refer to “8. HDCP SETTINGS AND EXECUTION”)

<Displaying the HDCP authentication screen>

(1)		
(2)	<p><Selecting HDCP></p> <p>Select HDCP using  or  , and then press .</p>	
(3)	<p><Detailed setting ></p> <p>For the detailed HDCP settings, refer to “8. HDCP SETTINGS AND EXECUTION.”</p>	

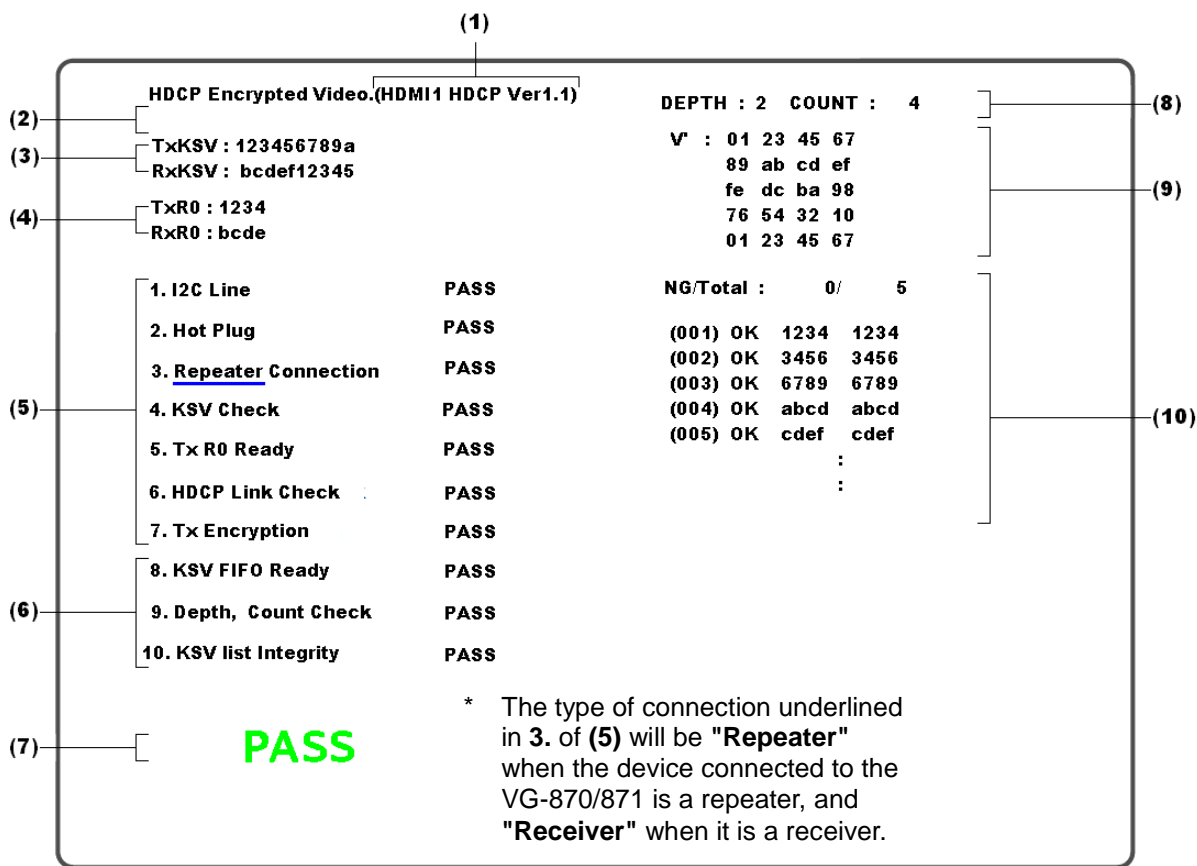

Details of the information shown on the screen are given below.

<HDCP authentication screen display data>

(1)	This indicates the port selected in c) Display Select of "8.2.1 Execution procedure" (When the HDCP authentication is successful, the HDCP version is displayed beside the port; when it has failed, an error message is displayed beside the port.)	
(2)	The EDID reading results are indicated here. (The results are displayed only when AUTO has been selected as the HDMI or DVI setting in "4.2.2 HDMI setting procedure" or when "EDID Check" has been selected as the Version setting in "8.1 HDCP settings.")	
(3)	The Key Selection Vectors are displayed here among the HDCP keys. "TxKSV" is the key selection vector of the transmitter; "RxKSV" is the key selection vector of the receiver.	
(4)	The Synchronization Verification Values calculated by the initial authentication are displayed here. "TxR0" is the value calculated for the transmitter; "RxR0" is the value calculated for the receiver.	
(5)	The authentication status of the initial authentication is displayed here.	An item with "PASS" denotes an item that has been successfully authenticated.
(6)*	The authentication status of the second authentication for a repeater is displayed here.	
(7)	If all the authentications have been carried out successfully, "PASS (green)" appears; otherwise, "NG (red)" appears.	
(8)*	The DEPTH (number of stages) and COUNT (total number of connections) of the devices connected beyond the receiver which in turn is connected to the VG-870B/871B/873/874 are shown here.	
(9)*	The value (V') shown here is for verifying the adequacy of the KSV list of the devices connected beyond of the receiver which in turn is connected to the VG-870B/871B/873/874.	
(10)	Shown here are the Synchronization Verification Values (Ri, Ri') for checking the adequacy of the link. Ri is the value calculated for the transmitter; Ri' is the value calculated for the receiver. "OK" is displayed when the transmitter and receiver values match. (If OK resulted from a retry, "OK2" is displayed instead.)	

* This information is displayed only when the device connected to the VG-870B/871B/873/874 is a repeater.

* Items (6) and (8) to (10) are not displayed for DisplayPort output.

6.13.6 HDMI list

The HDMI list display can be selected by pressing the NAME/LIST pattern key while the output from the HDMI connector is connected to the display. Information on the signals which are input to the display from the HDMI connector is shown on the display.

Example: HDMI list when EIA 1280 x 720 and 59.94 Hz output signals are supplied to the display

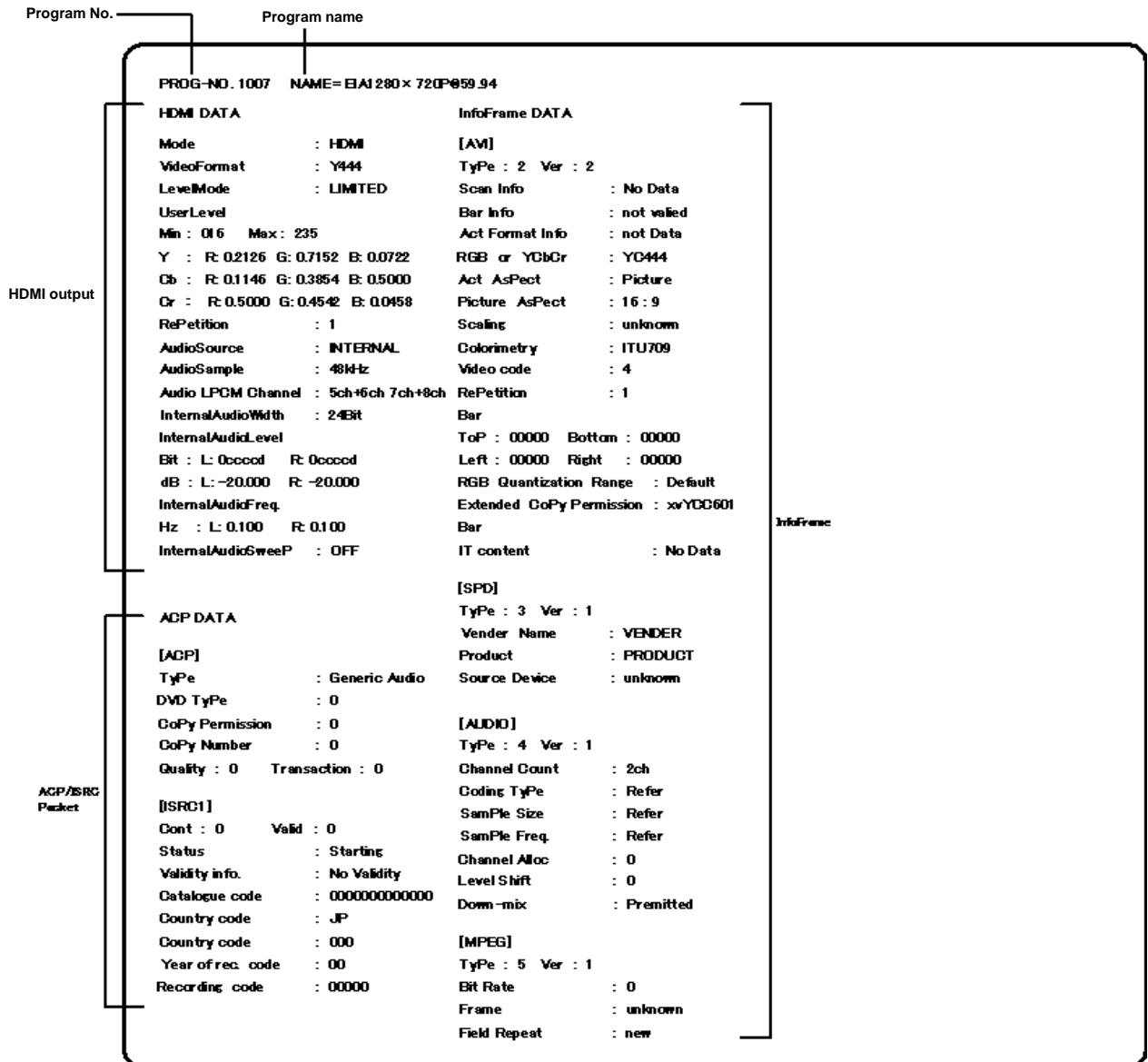

6.13.7 Timing data list

The timing data list display can be selected by pressing the NAME/LIST pattern key while the generator output is connected to the display. The timing data (such as the parameters) of the signals which are input to the display from the output connector is shown on the display.

Example: Timing list when EIA 1280 × 720 and 59.94 Hz output signals are supplied to the display

Program No.	Program name	Horizontal sync frequency	Vertical sync frequency	Program data enable/disable
PROG-NO. 1007	NAME= EIA1280 × 720P@59.94	H= 44.96KHz	V= 59.94Hz	ENABLE
Mode	: dot	Mode	: H	
CLOCK	: 74.176MHz	SCAN	: Progressive	
HPERIOD	: 22.24us	1650dot	SERRATION : 1H	
HDISP	: 17.26us	1280dot	EQP : OFF	
HSYNC	: 0.54us	40dot	VTOTAL1 : 16.883ms	750.0H
HBACKP	: 2.97us	220dot	VTOTAL2 : 16.016ms	720.0H
Hd_strt	: 0.00us	0dot	VSYNC1 : 0.111ms	5.0H
Hd_width	: 0.00us	0dot	VBACKP1 : 0.445ms	20.0H
			EQP FP1 : 0.000ms	0.0H
			EQP BP1 : 0.022ms	1.0H
HS	: POSI	TV-MODE	: HDTV720	
VS	: POSI			
CS	: NEGA			
SYNC ON		Freq L/R	: 1000Hz	1000Hz
VIDEO	: 0.70 V	Level L/R	: 2000mV	2000mV
SYNC	: 0.30 V	SWEEP	: OFF	
SETUP	: 0.00 V	STEP	: 40 msec	
RGB/YpPr	: YpPr	Times	: 0	
YpPr No.	: 0	Freq Min	: 200 Hz	
		Freq Max	: 20000 Hz	
		FreqSteP	: 200 Hz	
PC BNC	: ON	SamPFreq	: 48KHz	
PC DSUB	: ON	Digi CH0	: 0ccccdH	1000 Hz
PC DVI-I	: ON	Digi CH1	: 0ccccdH	1000 Hz
PC DVI-D	: ON	Digi CH2	: 0ccccdH	1000 Hz
TV VBBS	: OFF	Digi CH3	: 0ccccdH	1000 Hz
TV BNC	: ON	Digi CH4	: 0ccccdH	1000 Hz
TV SCON	: OFF	Digi CH5	: 0ccccdH	1000 Hz
TV DCON	: ON	Digi CH6	: 0ccccdH	1000 Hz
TV DSUB	: ON	Digi CH7	: 0ccccdH	1000 Hz
TV SCART1	: OFF			
TV SCART2	: OFF			
HDMI 1/2	: ON ON			

6.13.8 Image pattern list

When the image list display is selected by pressing the NAME/LIST key while the generator output is connected to the display, the information on the image patterns registered in the internal memory or on the CF card is shown on the display.

If the CF card has been inserted, the information on the CF card is displayed; otherwise, the information in the internal memory is displayed.

Internal memory or CF card		Free space [KB]		Page number/total number of pages	
Image Data List (Internal: 12345KB free) ... 1/1					
NO.	H, V- SIZE	COLOR	NAME	LICENSE	
1	(1024, 768)	24bit	owl	-	
101	(712, 484)	24bit	chi na Monoscope	available	
102	(1920, 1080)	24bit	carnati on girl	missing	
	⋮				

NO.: Image number

H, V-SIZE: Image size (width [dots], height [dots])

COLOR: Number of bits per dot

NAME: Image name

LICENSE: - No license required (standard)

available The license has been registered so the image list can be used. (option)

missing The license has not been registered so the image list cannot be used by this generator. (option)

If the total number of pages exceeds 2, the pages can be selected using 2 << / 3 >>.

6.13.9 OPT-USER pattern list

When the OPT-USER pattern list display is selected by pressing the NAME/LIST key while the generator output is connected to the display, the names and sizes of the user optional patterns registered in the internal memory or on the CF card are shown on the display.

If the CF card has been inserted, the names and sizes of the patterns on the CF card are displayed; otherwise, the names and sizes of the patterns in the internal memory are displayed.

Internal memory or CF card		Free space [KB]		Page number/total number of pages	
USER OPT Data List (Internal: 12345KB free) ... 1/1					
NO.	SIZE	NAME			
1	578	RGBW Color Bar			
100	676	10Step & 1/10MHz			
200	2549	Di splayPosi ti onAdj			
	⋮				

NO.: Pattern number

SIZE: Pattern size [bytes]

NAME: Pattern name

If the total number of pages exceeds 2, the pages can be selected using 2 << / 3 >>.

6.13.10 Subtitle

































The image patterns (*) created by the user are displayed.

Scrolling is possible using the action settings. (Refer to “7.5 Subtitle scrolling.”)



- * Unlike the images in “6.9 Image/OPT,” the images which can be displayed here are subject to restrictions on the number of colors and other aspects. They are created and registered using the Windows software program (SP-8870) which is provided with the VG generator. For details, refer to the operating instructions of the SP-8870.

The procedure for setting the parameters is outlined below.

<p>(1) Select Program Edit using  →  or  , and then press .</p>	
<p>(2) Select Pattern (PAT) using  or  , and then press .</p>	
<p>(3) Select Name/List using  or  , and then press .</p>	
<p>(4) Select Subtitle using  or  , and then press .</p>	
<p>(5) <Selecting the items> Select the items using  or  , and then press .</p> <p><Setting the parameters> Select the parameters using  or  , and then press .</p> <p>Alternatively: Select the parameters using the number keys  , and then press .</p>	<p>For details on the parameters, refer to <Table of subtitle setting items>.</p>

<Table of subtitle setting items>

(1)	No.	The number of the image pattern to be displayed is set here. Setting range: 1 to 200		
(2)	Position (0-9)	The position where the pattern is to be displayed is set here.		
		0	User Position	Setting position of User Position in (3)
		1	Top-Left	Top left
		2	Middle-Left	Center left
		3	Bottom-Left	Bottom left
		4	Top-Center	Center top
		5	Center	Center
		6	Bottom-Center	Center bottom
		7	Top-Right	Top right
		8	Middle-Right	Center right
9	Bottom-Right	Bottom right		
(3)	User Position	The desired display position (coordinate for the top left of the pattern) is set here. The setting takes effect when User Position has been selected as the Position setting. Setting range: 0 to 9999		
(4)	Color Select (0/1)	The display colors are set here.		
		0	File Data	The colors of the image pattern data are displayed in their original form.
		1	User Color	The settings for User Color1-3 in (5) are used.
(5)	User Color1 to 3 R,G,B	The desired display colors are set here. The setting takes effect when User Color has been selected as the Color Select setting.		
		The setting range differs depending on the color depth.		
		Color Depth	Setting range	
		8BIT	0 - 255	
		9BIT	0 - 511	
		10BIT	0 - 1023	
		11BIT	0 - 2047	
		12BIT	0 - 4095	
		13BIT	0 - 8191	
14BIT	0 - 16383			
15BIT	0 - 32767			
16BIT	0 - 65535			

6.14 Video black/white reversal

The video levels can be reversed.

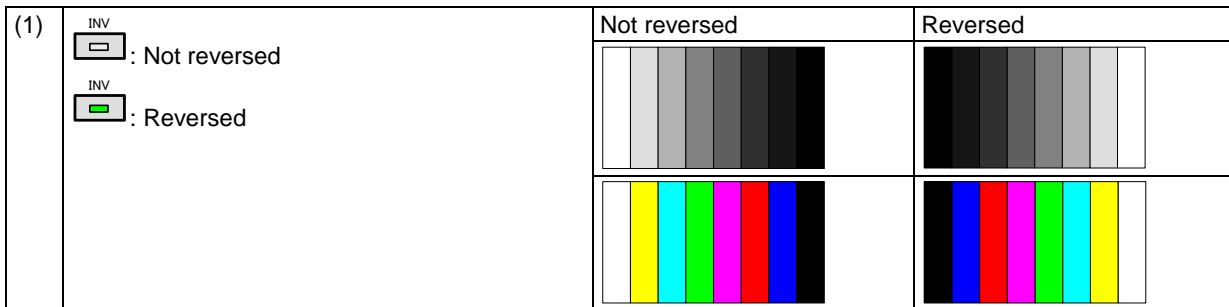

6.15 Simple animation

Simple animation sequences can be displayed by drawing a multiple number of images in the drawing area and moving the display start coordinates. The display method is described here uses an example of a simple animation sequence consisting of 640×480 images in nine frames.

6.15.1 Creating and registering the images

- (1) Create the images.

The 640×480 images in nine frames are created as a 1920×1440 image which is three frames wide and three frames high. (See Fig. 6-15-1.)

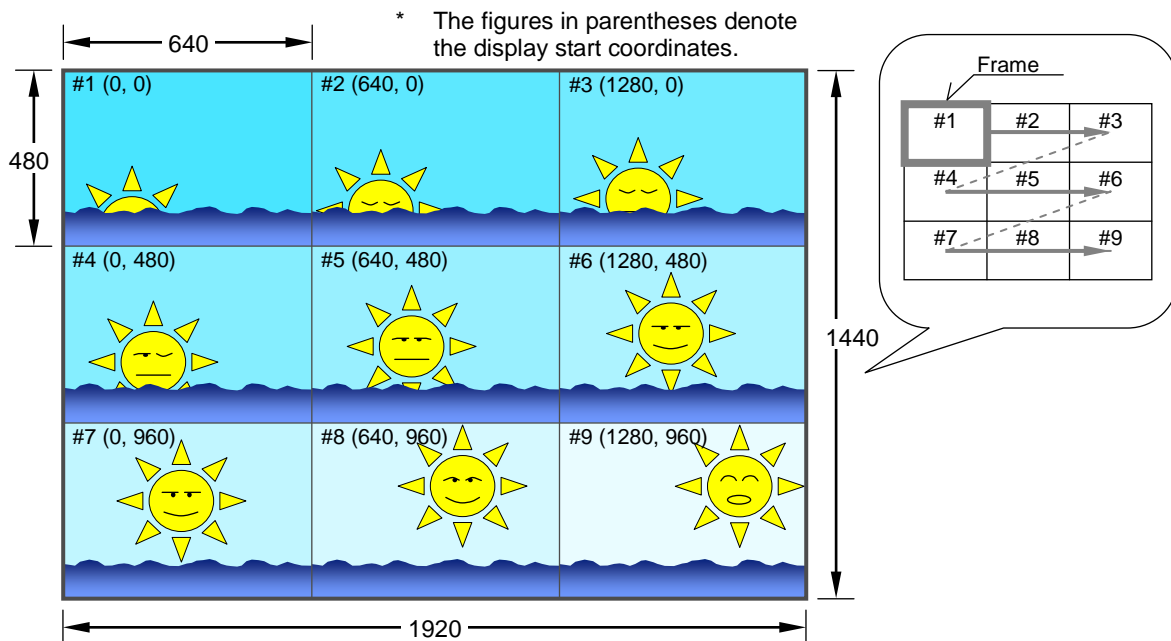

Fig. 6-15-1 Example of the images used for simple animation

* The display shows images #1 to #9 with a 640×480 frame size in the sequence of #1, #2 and so on up to #9.

- (2) Register the created images as image data (No.1 to 200) on the CF card using the Windows software (SP-8870) provided.



When creating simple animation images, create images whose resolution can be divided by 32 dots **when pasting images side by side**.

If the images have a resolution which cannot be divided by 32 dots, they will not be output properly.

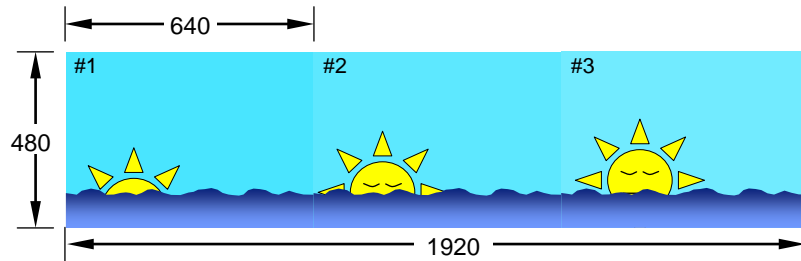

$$1920 / 32 = 60$$

Since the resolution can be divided by 32, images with this resolution are output properly.

If the above image has a resolution of 720 x 480

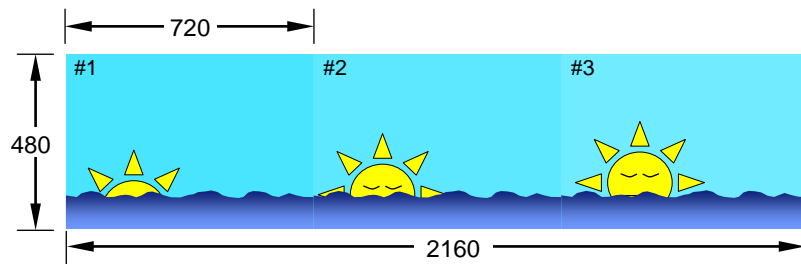

$$2160 / 32 = 67.5$$

Since the resolution cannot be divided by 32, images with this resolution are not output properly.

Images which have been pasted one on top of the other—even images which cannot be divided by 32 dots—are output properly.

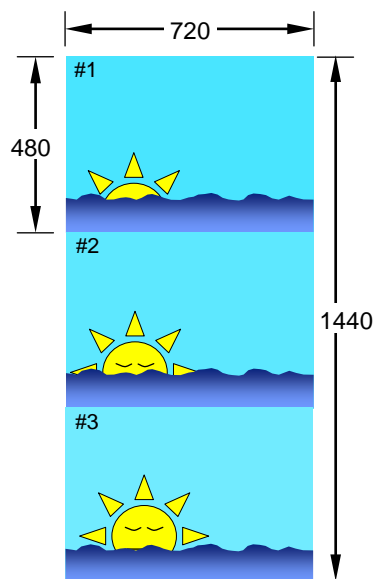

These images are not pasted side by side so they are output properly.

<Frame Sequential 3D patterns>







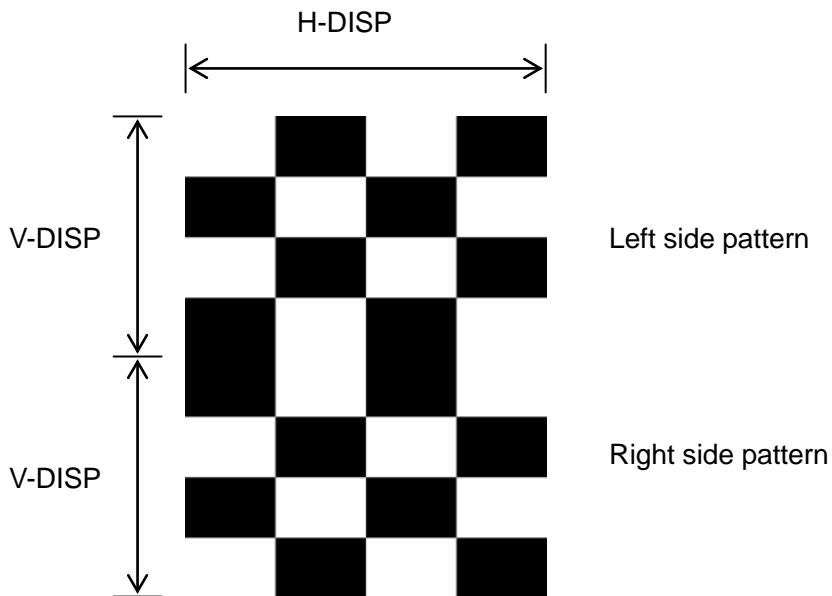







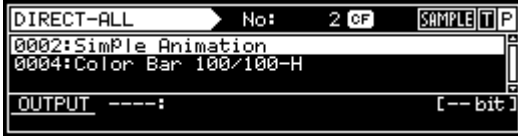









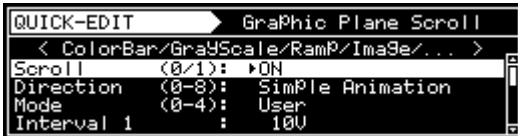

Patterns are drawn as shown in the figure below when **Frame Sequential** has been selected as the **Output Mode setting** among the 3D pattern (OPT No.101) settings in section 6.9.6.

This pattern is displayed at the left and right alternatively, and the **Frame Sequential** operation is performed by setting H=1 and V=2 as the values for the "Repeat" parameter among the simple animation settings in section 6.15.2.

The Interval1 parameter also takes effect at this time.



6.15.2 Simple animation settings

(1)	Insert the CF card containing the registered images. * At this point, check that  has not been pressed.									
(2)	Select the program No. using  or   , and then press  .									
(3)	<Setting Action> Select G-SCROLL using  and  , and then select EDIT using  .									
(4)	Select Graphic Plane using  or   , and then press  .									
(5)	<Selecting the items> Select the items using  or   , and then press  .									
	<Setting the parameters> Select the parameters using  or   , and then press  . Alternatively: Select the parameters using the number keys ( to ) , and then press  .	Set only the items below. <table border="1" data-bbox="861 1108 1492 1276"> <tbody> <tr> <td>Scroll</td> <td>ON (1)</td> </tr> <tr> <td>Direction</td> <td>Simple Animation (8)</td> </tr> <tr> <td>Interval1</td> <td>1 V to 255 V</td> </tr> <tr> <td>Repeat</td> <td>H = 3, V = 3 * This setting is for a 3 x 3 9-frame animation</td> </tr> </tbody> </table> * For details of the parameter settings, refer to “7.3 Graphic plane scrolling actions.” * Do not change any parameters not listed in the above table from their initial values.	Scroll	ON (1)	Direction	Simple Animation (8)	Interval1	1 V to 255 V	Repeat	H = 3, V = 3 * This setting is for a 3 x 3 9-frame animation
Scroll	ON (1)									
Direction	Simple Animation (8)									
Interval1	1 V to 255 V									
Repeat	H = 3, V = 3 * This setting is for a 3 x 3 9-frame animation									

7

ACTION SETTINGS



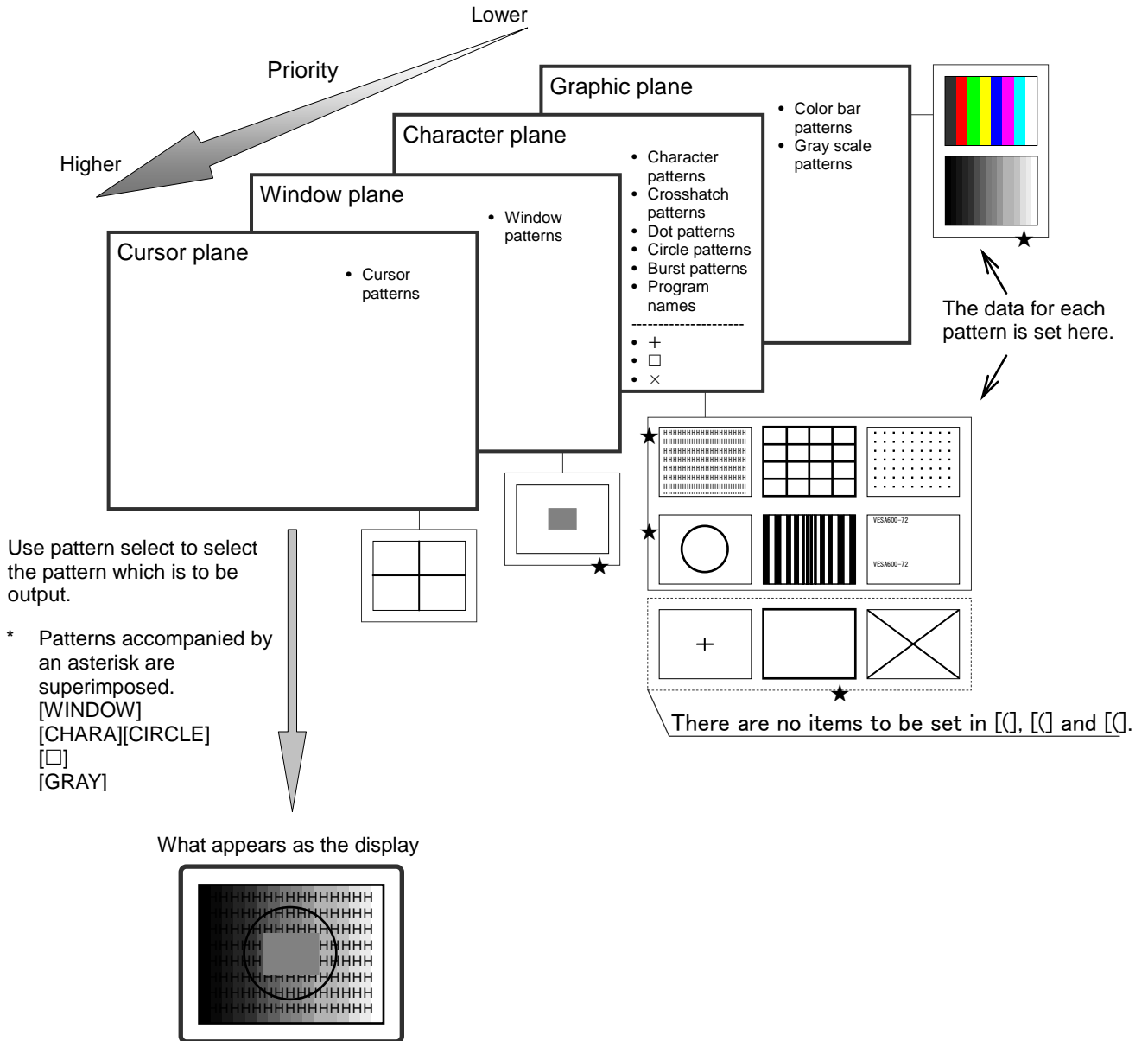











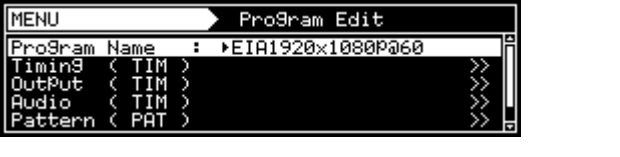



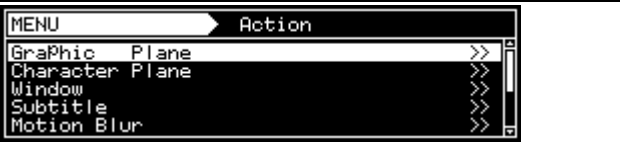











7.1 Concerning the planes



7.2 Window actions

7.2.1 Scrolling

For details on the action selection procedure, refer to “2.1.4 Selecting the actions.”





















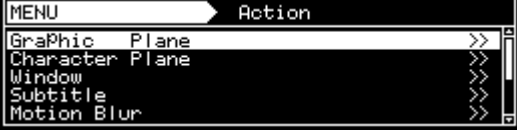











(1)	<p>Select Program Edit using  →  or  , and then press .</p>	
(2)	<p>Select Action (PAT) using  or  , and then press .</p>	
(3)	<p>Select Window using  or  , and then press .</p>	
(4)	<p>Select Scroll/Flicker using  or  , and then press .</p>	
(5)	<p><Selecting the items> Select the items using  or  , and then press .</p> <p><Setting the parameters> Select the parameters using  or  , and then press .</p> <p>Alternatively: Select the parameters using the number keys  to , and then press .</p>	<p>For further details, refer to <Table of scroll setting items>.</p>

<Table of scroll setting items>

(1)	OFF/ON (0/1)	On or Off is set for window scrolling here.		
		0	OFF	Window scrolling is set to Off.
		1	ON	Window scrolling is set to On.
(2)	Direction (0-A)	The direction of scrolling is set here.		
		0	Left	The window is scrolled toward the left.
		1	Right	The window is scrolled toward the right.
		2	Up	The window is scrolled upward.
		3	Down	The window is scrolled downward.
		4	Left Up	The window is scrolled toward the top left.
		5	Left Down	The window is scrolled toward the bottom left.
		6	Right Up	The window is scrolled toward the top right.
		7	Right Down	The window is scrolled toward the bottom right.
		8	Left<->Right	The window is scrolled toward the left and right.
		9	Up<->Down	The window is scrolled toward the top and bottom.
A	Random	The window is scrolled at random.		
(3)	Mode (0-4)	The interval (execution interval) mode for window scrolling is set here.		
		0	User	The window is scrolled as per the Interval 1-4 setting .
		1	60i->60i	The interval (execution interval) is set to 1 V.
		2	24p->60i 2-3PullDown	The interval (execution interval) is set to 2 V and 3 V, and repeated.
		3	25p->50i	The interval (execution interval) is set to 2 V.
4	30p->60i	The interval (execution interval) is set to 2 V.		
(4)	Interval (Interval 1)	The interval (execution interval) is set here. Setting range: 1 V to 255 V This setting takes effect only when User has been selected as the Mode setting .		
(5)	Step (Step 1)	The amount of movement per interval (execution interval) is set here.		
		H	Setting range: 1 dot to 255 dots This setting takes effect only when Left or Right has been selected as the Direction setting .	
		V	Setting range: 1H to 255H This setting takes effect only when Up or Down has been selected as the Direction setting .	
The following items are selected only when User has been selected as the Mode setting .				
(6)	Interval 2 to 4	The interval (execution interval) is set here. Setting range: 0 V to 255 V When a setting other than "0" has been selected, the conditions which have been set are repeated in sequence starting with Interval 1 . Example: Interval 1 → Interval 2 → Interval 3 → Interval 1 → ...		
(7)	Step 2 to 4	The amount of movement per interval (execution interval) is set here. The amount of movement corresponding to the Interval 2-4 setting is set.		
		H	Setting range: 0 dot to 255 dots This setting takes effect only when Left or Right has been selected as the Direction setting .	
		V	Setting range: 0H to 255H This setting takes effect only when Up or Down has been selected as the Direction setting .	

7.2.2 Flickering

For details on the action selection procedure, refer to “2.1.4 Selecting the actions”





















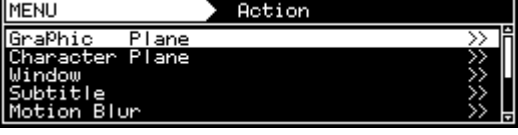











(1)	<p>Select Program Edit using  → </p> <p>or  , and then press </p>	
(2)	<p>Select Action (PAT) using  or </p> <p>, and then press </p>	
(3)	<p>Select Window using  or  ,</p> <p>and then press </p>	
(4)	<p>Select Flicker using  or  ,</p> <p>and then press </p>	
(5)	<p><Selecting the items></p> <p>Select the items using  or  ,</p> <p>and then press </p> <p><Setting the parameters></p> <p>Select the parameters  or  ,</p> <p>and then press .</p> <p>Alternatively: Select the parameters using the number keys  to , and then press .</p>	<p>For further details , refer to <Table of Flicker setting items>.</p>

<Table of Flicker setting items>

(1)	OFF/ON (0/1)	<p>On or Off is set for window flicker</p> <table border="1"> <tr> <td>0</td> <td>OFF</td> <td>Flicker is set to OFF</td> </tr> <tr> <td>1</td> <td>ON</td> <td>Flicker is set to ON</td> </tr> </table>	0	OFF	Flicker is set to OFF	1	ON	Flicker is set to ON
0	OFF	Flicker is set to OFF						
1	ON	Flicker is set to ON						
(2)	Interval	<p>The interval (execution interval) is set here. Setting range: 1 V to 255 V</p>						

7.2.3 Level up/down actions

For details on the action selection procedure, refer to “2.1.4 Selecting the actions.”































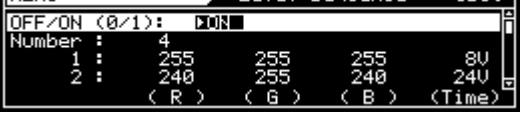

(1)	Select Program Edit using  →  or   , and then press  .	
(2)	Select Action (PAT) using  or  or  , and then press  .	
(3)	Select Window using  or   , and then press  .	
(4)	Select Level Up/Down using  or  or  , and then press  .	
(5)	<p><Selecting the items></p> Select the items using  or   , and then press  . <p><Setting the parameters></p> Select the parameters using  or  or  , and then press  . Alternatively: Select the parameters using the number keys ( to ), and then press  .	For further details, refer to <Table of level up/down setting items> .

<Table of level up/down setting items>

(1)	OFF/ON (0/1)	On or Off is set for level up/down here. 0 OFF Level up/down is set to Off. 1 ON Level up/down is set to On.
(2)	Direction (0/1)	Whether the level is to be increased or reduced is set here. 0 Up The level is increased. 1 Down The level is reduced.
(3)	Interval	The interval (execution interval) is set here. Setting range: 1 V to 255 V
(4)	Step	The amount of increase or reduction per interval (execution interval) is set here. Setting range: 1 to 255

7.2.4 Level sequence action

For details on the action selection procedure, refer to “2.1.4 Selecting the actions.”



























<p>(1) Select Program Edit using  →  or  INC  DEC, and then press .</p>	
<p>(2) Select Action (PAT) using  or  INC  DEC, and then press .</p>	
<p>(3) Select Window using  or  INC  DEC, and then press .</p>	
<p>(4) Select Level Sequence using  or  INC  DEC, and then press .</p>	
<p>(5) <Selecting the items> Select the items using  or  INC  DEC, and then press .</p> <p><Setting the parameters> Select the parameters using  or  INC  DEC, and then press .</p> <p>Alternatively: Select the parameters using the number keys ( to ), and then press .</p>	<p>For further details, refer to <Table of level sequence setting items>.</p>

<Table of level sequence setting items>

(1)	OFF/ON (0/1)	On or Off is set for level sequence here.		
		0	OFF	Level sequence is set to Off.
		1	ON	Level sequence is set to On.
(2)	Number	The number of level sequences is set here. Setting range: 1 to 16 The sequences are repeated in order for the number of times set here.		
(3)	1 to 16	The RGB levels and interval (execution interval) in each sequence are set here.		
		(R)	Set the R, G and B levels.	
		(G)	8-bit setting range:0 to 255	
		(B)	9-bit setting range:0 to 511	
			10-bit setting range:0 to 1023	
11-bit setting range:0 to 2047				
12-bit setting range:0 to 4095				
		13-bit setting range:0 to 8191		
		14-bit setting range:0 to 16383		
		15-bit setting range:0 to 32767		
		16-bit setting range:0 to 65535		
	(Time)	The interval (execution interval) is set here. Setting range: 1 V to 9999 V		

7.3 Graphic plane scrolling actions

For details on the action selection procedure, refer to “2.1.4 Selecting the actions.”

























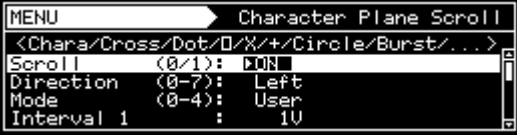



(1)	<p>Select Program Edit using  → </p> <p>or  , and then press .</p>	
(2)	<p>Select Action (PAT) using  or </p> <p>, and then press .</p>	
(3)	<p>Select Graphic Plane using  or </p> <p>, and then press .</p>	
(4)	<p><Selecting the items></p> <p>Select the items using  or  ,</p> <p>and then press .</p> <p><Setting the parameters></p> <p>Select the parameters using  or </p> <p>, and then press .</p> <p>Alternatively:</p> <p>Select the parameters using the number keys</p> <p> to , and then press .</p>	<p>For further details, refer to <Table of graphic plane setting items>.</p>

<Table of graphic plane setting items>

(1)	Scroll (0/1)	On or Off is set for scrolling here.	
		0	OFF Scrolling is set to Off.
		1	ON Scrolling is set to On.
(2)	Direction (0-8)	The direction of scrolling is set here.	
		0	Left The window is scrolled toward the left.
		1	Right The window is scrolled toward the right.
		2	Up The window is scrolled upward.
		3	Down The window is scrolled downward.
		4	Left Up The window is scrolled toward the top left.
		5	Left Down The window is scrolled toward the bottom left.
		6	Right Up The window is scrolled toward the top right.
		7	Right Down The window is scrolled toward the bottom right.
8	Simple Animation Simple animation For details, refer to "6.15.2 Simple animation settings."		
(3)	Mode (0-4)	The interval (execution interval) mode for scrolling is set here.	
		0	User The window is scrolled as per the Interval 1-4 setting .
		1	60i->60i The interval (execution interval) is set to 1 V.
		2	24p->60i 2-3PullDown The interval (execution interval) is set to 2 V and 3 V, and repeated.
		3	25p->50i The interval (execution interval) is set to 2 V.
4	30p->60i The interval (execution interval) is set to 2 V.		
(4)	Interval (Interval 1)	The interval (execution interval) is set here. Setting range: 1 V to 255 V This setting takes effect only when User has been selected as the Mode setting .	
(5)	Step (Step 1)	The amount of movement per interval (execution interval) is set here.	
		H	Setting range: 1 dot to 4095 dots This setting takes effect only when Left or Right has been selected as the Direction setting .
		V	Setting range: 1H to 4095H This setting takes effect only when Up or Down has been selected as the Direction setting .
The following items are selected only when User has been selected as the Mode setting .			
(6)	Interval 2 to 4	The interval (execution interval) is set here. Setting range: 0 V to 255 V When a setting other than "0" has been selected, the conditions which have been set are repeated in sequence starting with Interval 1 . Example: Interval 1 → Interval 2 → Interval 3 → Interval 1 → ...	
(7)	Step 2 to 4	The amount of movement per interval (execution interval) is set here. The amount of movement corresponding to the Interval 2-4 setting is set.	
		H	Setting range: 0 dot to 4095 dots This setting takes effect only when Left or Right has been selected as the Direction setting .
		V	Setting range: 0H to 4095H This setting takes effect only when Up or Down has been selected as the Direction setting .
(8)	Repeat	The number of images in the width and height dimensions to be used for the simple animation is specified here. For details, refer to "6.15.2 Simple animation settings."	
		H	Setting range: 1 to 16 The number of images arranged horizontally is specified here.
		V	Setting range: 1 to 64 The number of images arranged vertically is specified here.

7.4 Character plane scrolling actions

For details on the action selection procedure, refer to “2.1.4 Selecting the actions.”

























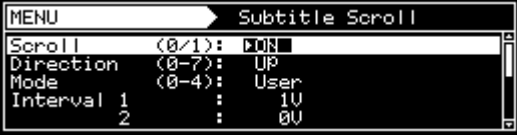

(1)	<p>Select Program Edit using  → </p> <p>or  INC  DEC, and then press .</p>	
(2)	<p>Select Action (PAT) using  or </p> <p> DEC, and then press .</p>	
(3)	<p>Select Character Plane using  or </p> <p> DEC, and then press .</p>	
(4)	<p><Selecting the items></p> <p>Select the items using  or </p> <p> DEC, and then press .</p> <p><Setting the parameters></p> <p>Select the parameters using  or </p> <p> DEC, and then press .</p> <p>Alternatively: Select the parameters using the number keys 0/STATUS  9/F </p> <p>( to ), and then press .</p>	<p>For further details, refer to <Table of character plane setting items>.</p>

<Table of character plane setting items>

(1)	Scroll (0/1)	On or Off is set for scrolling here.		
		0	OFF	Scrolling is set to Off.
		1	ON	Scrolling is set to On.
(2)	Direction (0-7)	The direction of scrolling is set here.		
		0	Left	The window is scrolled toward the left.
		1	Right	The window is scrolled toward the right.
		2	Up	The window is scrolled upward.
		3	Down	The window is scrolled downward.
		4	Left Up	The window is scrolled toward the top left.
		5	Left Down	The window is scrolled toward the bottom left.
		6	Right Up	The window is scrolled toward the top right.
7	Right Down	The window is scrolled toward the bottom right.		
(3)	Mode (0-4)	The interval (execution interval) mode for scrolling is set here.		
		0	User	The window is scrolled as per the Interval 1-4 setting .
		1	60i->60i	The interval (execution interval) is set to 1 V.
		2	24p->60i 2-3PullDown	The interval (execution interval) is set to 2 V and 3 V, and repeated.
		3	25p->50i	The interval (execution interval) is set to 2 V.
4	30p->60i	The interval (execution interval) is set to 2 V.		
(4)	Interval (Interval 1)	The interval (execution interval) is set here. Setting range: 1 V to 255 V This setting takes effect only when User has been selected as the Mode setting .		
(5)	Step (Step 1)	The amount of movement per interval (execution interval) is set here.		
		H	Setting range: 1 dot to 4095 dots This setting takes effect only when Left or Right has been selected as the Direction setting .	
		V	Setting range: 1H to 4095H This setting takes effect only when Up or Down has been selected as the Direction setting .	
The following items are selected only when User has been selected as the Mode setting .				
(6)	Interval 2 to 4	The interval (execution interval) is set here. Setting range: 0 V to 255 V When a setting other than "0" has been selected, the conditions which have been set are repeated in sequence starting with Interval 1 . Example: Interval 1 → Interval 2 → Interval 3 → Interval 1 → ...		
(7)	Step 2 to 4	The amount of movement per interval (execution interval) is set here. The amount of movement corresponding to the Interval 2-4 setting is set.		
		H	Setting range: 0 dot to 4095 dots This setting takes effect only when Left or Right has been selected as the Direction setting .	
		V	Setting range: 0H to 4095H This setting takes effect only when Up or Down has been selected as the Direction setting .	

7.5 Subtitle scrolling

For details on the action selection procedure, refer to “2.1.4 Selecting the actions.”

(1)	<p>Select Program Edit using  →  or  INC  DEC, and then press .</p>	
(2)	<p>Select Action (PAT) using  or  INC  DEC, and then press .</p>	
(3)	<p>Select Subtitle using  or  INC  DEC, and then press .</p>	
(4)	<p><Selecting the items> Select the items using  or  INC  DEC, and then press .</p> <p><Setting the parameters> Select the parameters using  or  INC  DEC, and then press .</p> <p>Alternatively: Select the parameters using the number keys  to , and then press .</p>	<p>For details, refer to the <Table of subtitle scroll setting items>.</p>

<Table of subtitle scroll setting items>

(1)	Scroll(0/1)	Scrolling is set to On or Off here.	
		0	OFF Scrolling is set to Off.
		1	ON Scrolling is set to On.
(2)	Direction(0-7)	The scrolling direction is set here.	
		0	Left The subtitles are scrolled to the left.
		1	Right The subtitles are scrolled to the right.
		2	Up The subtitles are scrolled to the top.
		3	Down The subtitles are scrolled to the bottom.
		4	Left Up The subtitles are scrolled to the top left.
		5	Left Down The subtitles are scrolled to the bottom left.
		6	Right Up The subtitles are scrolled to the top right.
7	Right Down The subtitles are scrolled to the bottom right.		
(3)	Mode(0-4)	The scrolling interval (execution interval) mode is specified here.	
		0	User Scrolling is executed in compliance with the Interval 1, 2, 3 or 4 setting.
		1	60i->60i 1V serves as the interval (execution interval).
		2	24p->60i 2-3PullDown 2V and 3V are repeated as the interval (execution interval).
		3	25p->50i 2V serves as the interval (execution interval).
4	30p->60i 2V serves as the interval (execution interval).		
(4)	Interval(Interval 1)	The interval (execution interval) is set here. Setting range: 1 V to 255 V This item can be set only when User has been selected as the Mode setting. In all other modes, a fixed value is displayed.	
(5)	Step(Step 1)	The amount of movement per interval (execution interval) is set here.	
		H	Setting range: 1 dot to 4095 dots This item takes effect only when Left or Right has been selected as the Direction setting.
		V	Setting range: 1 H to 4095 H This item takes effect only when Up or Down has been selected as the Direction setting.
The items listed below are set only when User has been selected as the Mode setting.			
(6)	Interval 2 - 4	The interval (execution interval) is set here. Setting range: 0 V to 255 V When a setting other than "0" has been set, the set conditions are repeated in sequence starting from Interval 1 . Example: Interval 1 → Interval 2 → Interval 3 → Interval 1 → ...	
(7)	Step 2 - 4	The amount of movement per interval (execution interval) is set here. This is the amount of movement (step) which corresponds to the Interval 2-4 settings.	
		H	Setting range: 0 dot to 255 dots This item takes effect only when Left or Right has been selected as the Direction setting.
		V	Setting range: 0 H to 255 H This item takes effect only when Up or Down has been selected as the Direction setting.

7.6 0.25- and 0.125-dot scrolling actions (option)

0.25-dot and 0.125-dot scrolling can be set.

This function is optional. (The 0.25 dot and 0.125 dot are separate options.)

For further details, contact your dealer or an ASTRODESIGN sales representative.

- Concerning 0.25- and 0.125-dot scrolling

The setting increments used by the regular scrolling function are interval 1 V increments (frames for progressive scanning and fields for interlaced scanning), and 1-dot increments are used for the movement amounts.

In the case of the VG-870B,871B,873,874 smoother scrolling can be achieved by providing four patterns with a 0.25-dot shift in between (or two patterns with a 0.5-dot shift and 8 patterns with a 0.125-dot shift).

<Example>

When scrolling horizontally for one round at a 1920 × 1080p @ 60p timing of approximately 5 seconds

About 13 dots are required per 2 V and about 6.5 dots (*1) per 1 V.

$$*1: \text{Amount of movement per 1 V} = 1920 / (60 * 5) = 6.4 \approx 6.5 \text{ [dot]}$$

Standard setting (1)

Amount of movement in 6, 7, 6, 7
..... dots per frame

Standard setting (2)

Movement by 13 dots per 2
frames

0.5-dot scrolling

Movement by 6.5 dots per frame

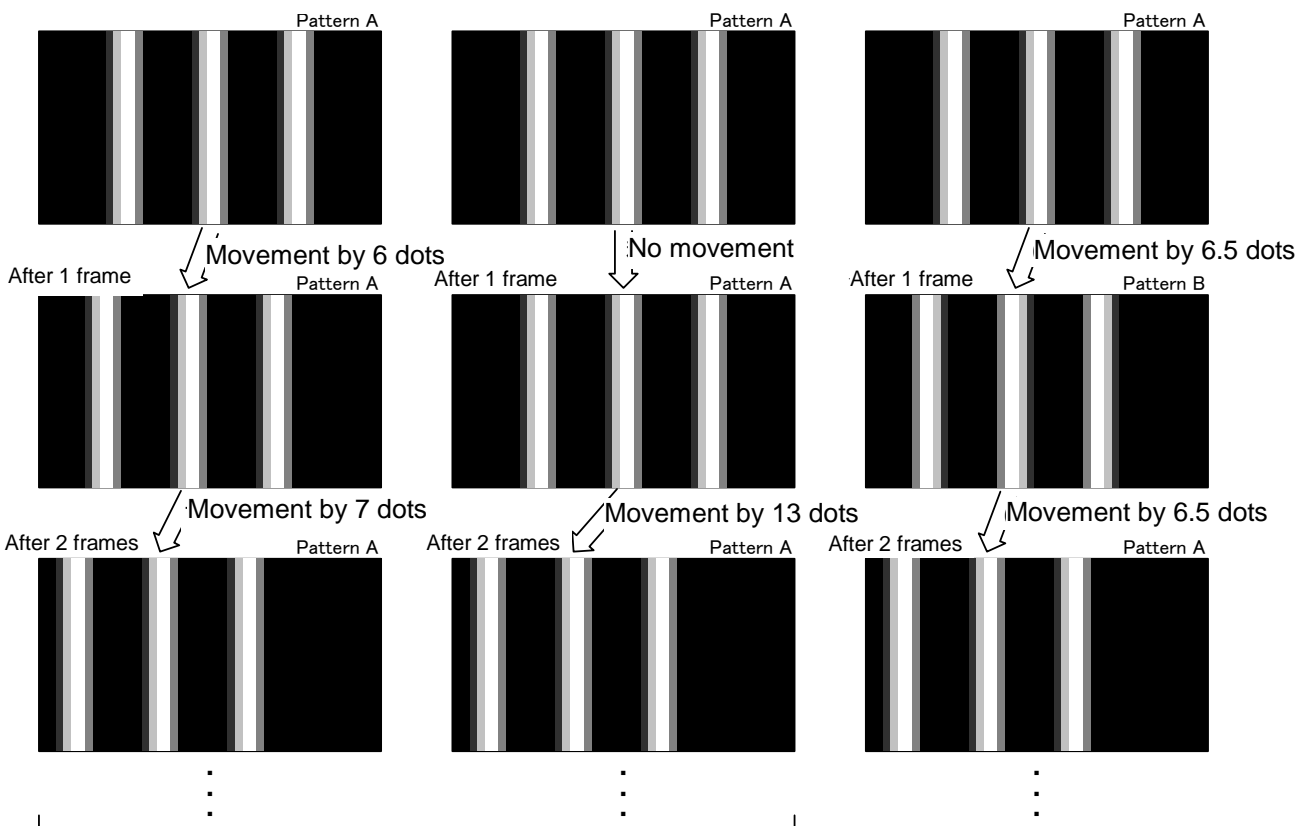

Movement is not smooth.

Smooth scrolling is enabled.

Pattern A: Pattern serving as the reference

Pattern B: Pattern produced when pattern A is moved by 0.5 dot.



The 0.25-/0.125-dot scrolling function takes effect only for the image data created by the user.

With 0.5-dot scrolling

Two patterns, with one offset by 0.5 dot from the other, are created.



Pattern produced when pattern A is moved 0.5 dot to the left.

With 0.25-dot scrolling

Four patterns, each offset by 0.25 dot from the others, are created.

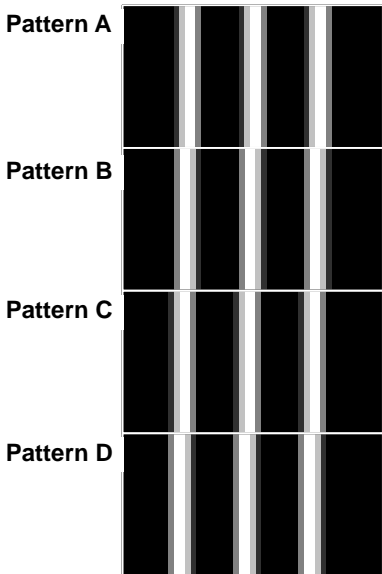

Pattern produced when pattern A is moved 0.25 dot to the left.

Movement by 0.25 dot to the left

Movement by 0.25 dot to the left

With 0.125-dot scrolling

Eight patterns, with one offset by 0.125 dot from the other, are created.

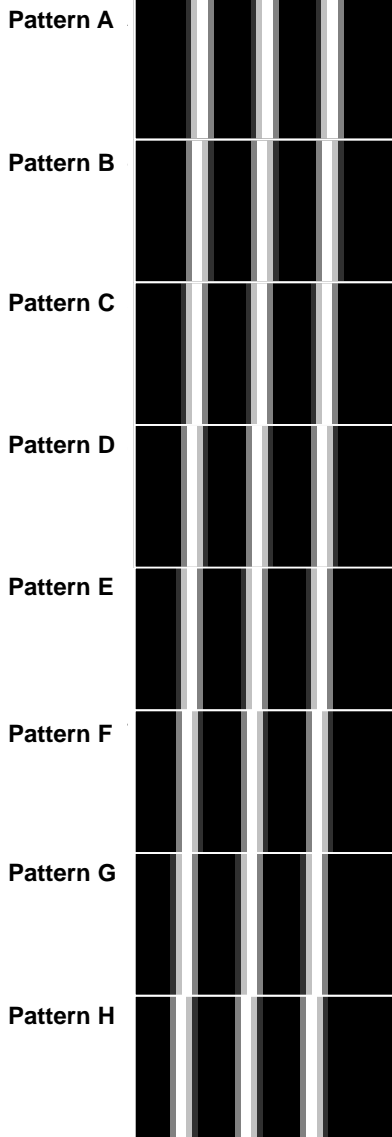

Pattern produced when pattern A is moved 0.125 dot to the left.

Movement by 0.125 dot to the left

Movement by 0.125 dot to the left

Movement by 0.125 dot to the left





















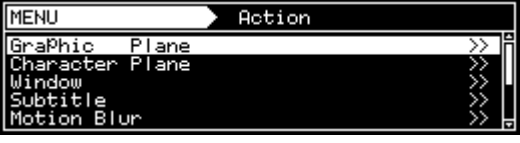



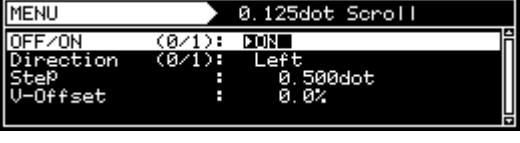

Movement by 0.125 dot to the left

Movement by 0.125 dot to the left

Movement by 0.125 dot to the left

● 0.25-/0.125-dot scrolling settings

For details on the action selection procedure, refer to “2.1.4 Selecting the actions.”

<p>(1) Select Program Edit using    or  , and then press .</p>	
<p>(2) Select Action (PAT) using  or  , and then press .</p>	
<p>(3) Select “0.25dot Scroll” or “0.125dot Scroll” using  or  , and then press .</p>	
<p>(4) <Selecting the items> Select the items using  or  , and then press .</p> <p><Setting the parameters> Select the parameters using  or  , and then press .</p> <p>Alternatively: Select the parameters using the number keys   , and then press .</p>	<p>For further details, refer to <Table of 0.25-/0.125-dot scrolling setting items>.</p>

<Table of 0.25-dot and 0.125-dot scroll setting items>

(1)	OFF/ON (0/1)	On or Off for 0.25-/0.125-dot scrolling is set here. 0 OFF 0.25-/0.125-dot scrolling is set to Off. 1 ON 0.25-/0.125-dot scrolling is set to On.
(2)	Direction (0/1)	The direction of 0.25-/0.125-dot scrolling is set here. 0 Left Scrolling moves to the left. 1 Right Scrolling moves to the right.
(3)	Step	The amount of movement per 1 V is set here. 0.25-dot scroll setting range: 0.00 dot to 254.75 dots (0.25 dot Step) 0.125-dot scroll setting range: 0.000 dot to 254.750 dot (0.125 dot Step)
(4)	V-offset	The value of V-offset is set here. Setting range: 0.0 to 100.0% (0.1% Step)

7.7 Motion blur

Motion blur is a function for displaying up to 16 of the specified patterns described later, and moving them.





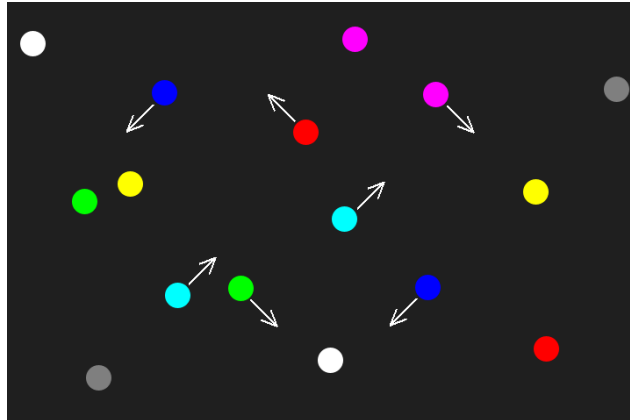















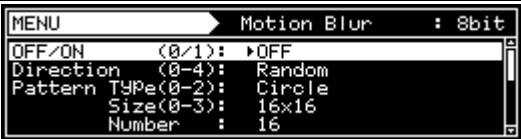

The patterns to be displayed using this function can be combined with other patterns (excluding the cursor), and displayed.

<Display example: Random movement direction>



The setting procedure is described below.

For details on the action selection procedure, refer to “2.1.4 Selecting the actions.”

(1)	Select Program Edit using  or  or  , and then press  .	
(2)	Select Action (PAT) using  or  , and then press  .	
(3)	Select Motion Blur using  or  , and then press  .	
(4)	<p><Selecting the items></p> Select the items using  or  , and then press  . <p><Setting the parameters></p> Select the parameters using  or  , and then press  . Alternatively: Select the parameters using the number keys ( to ) , and then press  .	For further details, refer to <Table of motion blur setting items>.

<Table of motion blur setting items>

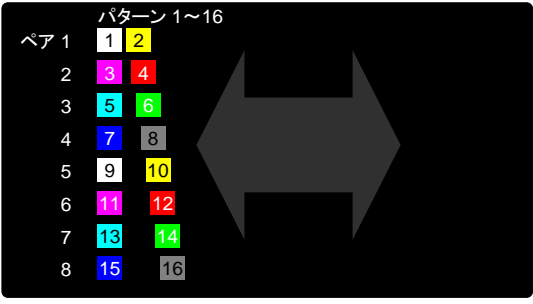
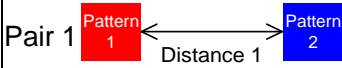
(1)	OFF/ON (0/1)	This is used to set the motion blur function to ON or OFF.	
		0	OFF
		1	ON
(2)	Direction (0-4)	The direction of the pattern movement is specified here.	
		0	Top-L<->Bottom-R Top left ⇔ bottom right
		1	Left<->Right Left ⇔ right
		2	2:Up<->Down Up ⇔ down
		3	Random Random
		4	Left<->Right Pair Left ⇔ right pair
			
(3)	Pattern Type (0-2)	The shape of the pattern is specified here.	
		0	Circle Circle
		1	Square Square
		2	USER Character User character Setting range: E0h - FFh
(4)	Pattern Size (0-3)	The size of the pattern is specified here. (dot)	
		0	8 × 8
		1	16 × 16
		2	32 × 32
		3	64 × 64
(5)	Pattern Number	The number of patterns to be displayed is set here. Setting range: 1 - 16	
		* The Direction >Left<->Right Pair setting is available only when 2, 4, 8, or 16 is specified as the number of patterns. Even if a number other than 2, 4, 8, or 16 is specified, the number of patterns will be 2, 4, 8, or 16.	
(6)	Distance	When the Direction >Left<->Right Pair setting is selected, the pattern interval for each pair is specified here. Setting range: 0 to 255 [dot]	
			
(7)	Step InpMode (0/1)	The step setting method is specified here.	
		0	All All the patterns are set together.
		1	Separate The patterns are set individually.
(8)	Step (/1 V)	The amount of pattern movement per 1 V (progressive scanning: frame; interlaced scanning: field) is set here. Setting range: 1 - 255 [dot]	
		* When the Direction >Left<->Right Pair setting is selected, the amount of movement is specified for each pair (pair 1 to 8).	

(9)	Color InpMode (0/1)	The color setting method is specified here.																					
		0 All	All the patterns are set together.																				
		1 Separate	The patterns are set individually.																				
(10)	Color	<p>The pattern colors (R/G/B levels) are set here. The colors for patterns 9 to 16 are the same as for patterns 1 to 8. The setting range differs depending on the pattern drawing bit length (Color Depth).</p> <table border="1"> <thead> <tr> <th>Color Depth</th> <th>Setting range</th> </tr> </thead> <tbody> <tr><td>8bit</td><td>0 - 255</td></tr> <tr><td>9bit</td><td>0 - 511</td></tr> <tr><td>10bit</td><td>0 - 1023</td></tr> <tr><td>11bit</td><td>0 - 2047</td></tr> <tr><td>12bit</td><td>0 - 4095</td></tr> <tr><td>13bit</td><td>0 - 8191</td></tr> <tr><td>14bit</td><td>0 - 16383</td></tr> <tr><td>15bit</td><td>0 - 32767</td></tr> <tr><td>16bit</td><td>0 - 65535</td></tr> </tbody> </table>		Color Depth	Setting range	8bit	0 - 255	9bit	0 - 511	10bit	0 - 1023	11bit	0 - 2047	12bit	0 - 4095	13bit	0 - 8191	14bit	0 - 16383	15bit	0 - 32767	16bit	0 - 65535
Color Depth	Setting range																						
8bit	0 - 255																						
9bit	0 - 511																						
10bit	0 - 1023																						
11bit	0 - 2047																						
12bit	0 - 4095																						
13bit	0 - 8191																						
14bit	0 - 16383																						
15bit	0 - 32767																						
16bit	0 - 65535																						
(11)	OPT Back R,G,B	The background color (R/G/B levels) is specified here when the internal optional pattern No.71 (Motion Blur Line) has been selected. The setting range is the same as for the Color setting item .																					
(12)	Area H/V	The pattern movement range is set as a percentage of H/V-Timing Disp. Setting range: 0 - 100 [%]																					

<Concerning the internal optional pattern No.71>

Internal optional pattern No.71 (Motion Blur Line) is the pattern which displays the aspects of the Motion Blur>Step setting and other setting items.

What is displayed depends on the Direction setting.

The background color can be set using OPT Back.

- (1) When the Direction>Top-L<->Bottom-R, Left<->Right, or Up<->Down setting is selected

The Step and its path line are displayed in white.

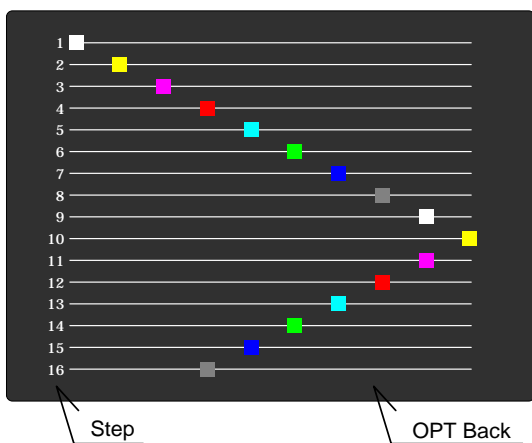

- (2) When the Direction>Left<->Right setting is selected

The Step and Distance are displayed in white.

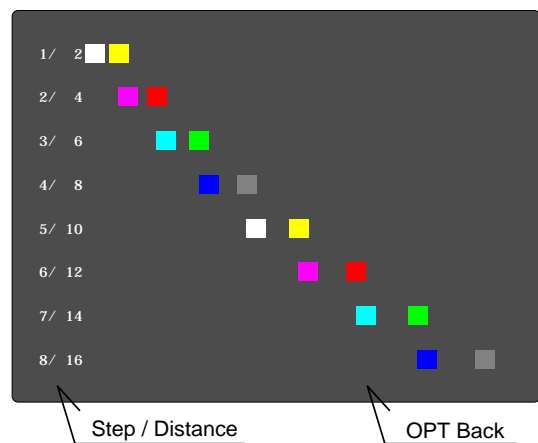























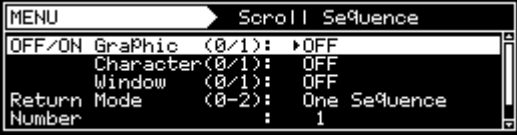



- (3) When the Direction>Random setting is selected

The frames are displayed in white.

7.8 Scroll Sequence

Sequence numbers for each plane can set up to 16 by scroll sequence setting.

(1)	<p>Select Program Edit using  →  or  INC  DEC, and then press .</p>	 <pre> MENU Program Edit Program Name : ▶EIA1920x1080Pa60 Timing (TIM) : >>> OutPut (TIM) : >>> Audio (TIM) : >>> Pattern (PAT): >>> </pre>
(2)	<p>Select Action using  or  INC  DEC, and then press .</p>	 <pre> MENU Action Motion Blur : >> 0.5/0.25dot Scroll : >> Scroll Sequence : >> LiP Sync : >> Black Insertion : >> </pre>
(3)	<p>Select Scroll Sequence using  or  INC  DEC, and then press .</p>	 <pre> MENU Scroll Sequence OFF/ON Graphic (0/1): ▶OFF Character(0/1): OFF Window (0/1): OFF Return Mode (0-2): One Sequence Number : 1 </pre>
(4)	<p>Select the items using  or  INC  DEC, and then press .</p> <p><Setting the parameters></p> <p>Select the parameters using  or  INC  DEC, and then press .</p> <p>Alternatively: Select the parameters using the number keys  to , and then press .</p>	<p>For further details, refer to <table of Scroll Sequence setting items>.</p>





















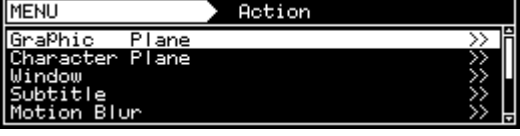



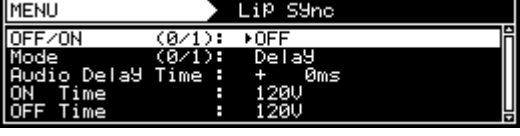

<The table of Scroll Sequence setting items>

(1)	OFF/ON (0/1)	On or Off is set for graphic/character/window plane here.	
		0	OFF
		1	ON
(2)	Return Mode (0/2)	The mode to restore the scroll position is set here.	
		0	One Sequence Restore per sequence scroll position
		1	All Sequence Restore entire sequence scroll positions.
		2	Random The scroll position is not restored. In this mode, the Parameter settings (scroll direction, execution interval, movement amount and execution time) are changed at random for each sequence regardless of the values which have been set. However, with the exception of Direction, the set values are used as the upper limits.
(3)	Number	Set the number of sequence Setting range: 1-16	
Parameter			
(1)	Direction	The direction of scrolling is set here	
		0	L The window is scrolled toward the left.
		1	R The window is scrolled toward the right.
		2	U The window is scrolled upward.
		3	D The window is scrolled downward.
		4	L-U The window is scrolled toward the top left.
		5	L-D The window is scrolled toward the bottom left.
		6	R-U The window is scrolled toward the top right.
		7	R-D The window is scrolled toward the bottom right.
(2)	Interval	The interval (execution interval) is set here. Setting range: 1 - 255 V	
(3)	H Step	The amount of horizontal movement per interval (execution interval) movement is set here. Setting range: 1 - 255 dot	
(4)	V Step	The amount of vertical movement per interval (execution interval) movement is set here. Setting range: 1 - 255 H	
(5)	Time	Execution time per sequence is set here. Setting range: 1 - 999 V	



7.9 LipSync

For details on the action selection procedure, refer to “2.1.4 Selecting the actions.”

The lip sync function can be used to set a difference between the audio phase and video phase.



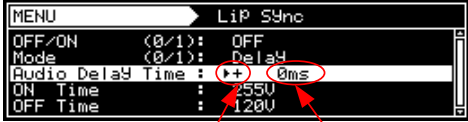

















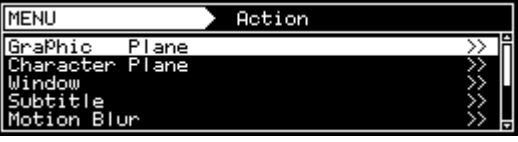





(1)	<p>Select Program Edit using  →  or  , and then press .</p>	 <pre> MENU → Program Edit Program Name : ▶EIA1920x1080P360 Timing < TIM > >> Output < TIM > >> Audio < TIM > >> Pattern < PAT > >> </pre>
(2)	<p>Select Action (PAT) using  or  , and then press .</p>	 <pre> MENU → Action Graphic Plane >> Character Plane >> Window >> Subtitle >> Motion Blur >> </pre>
(3)	<p>Select Lip Sync using  or  , and then press .</p>	 <pre> MENU → Lip Sync OFF/ON < 0/1 > : ▶OFF Mode < 0/1 > : Delay Audio Delay Time : + 0ms ON Time : 120U OFF Time : 120U </pre>
(4)	<p>Select the items using  or  , and then press .</p> <p><Setting the parameters></p> <p>Select the parameters using  or  , and then press .</p> <p>Alternatively: Select the parameters using the number keys ( to ), and then press .</p>	<p>For further details, refer to <Table of lip sync setting items>.</p>

<Table of LipSync setting items>

(1)	OFF/ON(0/1)	Whether to set the lip sync function on or off is set here.	
		0 OFF	Disabled
		1 ON	Enabled
(2)	Mode(0/1)	The method used to set the delay amount (time) is set here.	
		0 Delay	The delay amount of the user's choice is set.
		1 EDID	The delay amount accords with the EDID of the connection destination. (Automatically set)
(3)	When Delay has been selected as the Mode setting Audio Delay Time	The delay amount is set here as a time.	
			
		Sign: Indicates behind or ahead.	
		0 +	The audio is behind the video.
		1 -	The audio is ahead of the video.
	Time: The time is set here.		
	When EDID has been selected as the Mode setting EDID Port	The port used to read the EDID is set here. Operation is initiated using the amount of delay defined in the EDID concerned.	
			
		0 HDMI1	The EDID is read from HDMI1.
		1 HDMI2	The EDID is read from HDMI2.
(4)	On Time	The audio output time and raster (white) display time are set using the vertical sync signal (in 1-frame increments). Setting range: 1 V to 255 V	
(5)	OFF Time	The audio no output time and display OFF (black) time are set using the vertical sync signal (in 1-frame increments). Setting range: 1 V to 255 V	

7.10 Black insertion action

For details on the action selection procedure, refer to “2.1.4 Selecting the actions.”

(1)	<p>Select Program Edit using  →  or  INC  DEC, and then press .</p>	 <pre> MENU → Program Edit Program Name : ▶EIA1920x1080Pa60 Timing (TIM) >>> Output (TIM) >>> Audio (TIM) >>> Pattern (PAT) >>> </pre>
(2)	<p>Select Action (PAT) using  or  INC  DEC, and then press .</p>	 <pre> MENU → Action Graphic Plane >>> Character Plane >>> Window >>> Subtitle >>> Motion Blur >>> </pre>
(3)	<p>Select Black Insertion using  or  INC  DEC, and then press .</p>	 <pre> MENU → Black Insertion Insertion (0/1): ON Position (0-2): All Pattern Display Time: 00 Black Insertion Time: 00 </pre>
(4)	<p><Selecting the items> Select the items using  or  INC  DEC, and then press .</p> <p><Setting the parameters> Select the parameters using  or  INC  DEC, and then press .</p> <p>Alternatively: Select the parameters using the number keys  to , and then press .</p>	<p>For further details, refer to <Table of black insertion setting items>.</p>

<Table of black insertion setting items>









(1)	Insertion (0/1)	<p>On or Off for black insertion is set here.</p> <table border="1"> <tr> <td>0</td> <td>OFF</td> <td>Black insertion is set to Off.</td> </tr> <tr> <td>1</td> <td>ON</td> <td>Black insertion is set to On.</td> </tr> </table>	0	OFF	Black insertion is set to Off.	1	ON	Black insertion is set to On.			
0	OFF	Black insertion is set to Off.									
1	ON	Black insertion is set to On.									
(2)	Position (0-2)	<p>The black insertion position is set here.</p> <table border="1"> <tr> <td>0</td> <td>All</td> <td>The entire screen is subject to the black insertion.</td> </tr> <tr> <td>1</td> <td>Left Half</td> <td>The left half of the screen is subject to the black insertion.</td> </tr> <tr> <td>2</td> <td>Right Half</td> <td>The right half of the screen is subject to the black insertion.</td> </tr> </table>	0	All	The entire screen is subject to the black insertion.	1	Left Half	The left half of the screen is subject to the black insertion.	2	Right Half	The right half of the screen is subject to the black insertion.
0	All	The entire screen is subject to the black insertion.									
1	Left Half	The left half of the screen is subject to the black insertion.									
2	Right Half	The right half of the screen is subject to the black insertion.									
(3)	Pattern Display Time	<p>The time during which the pattern is to be displayed is set here. Setting range: 0 V to 255 V</p>									
(4)	Black Insertion Time	<p>The time during which black insertion is to take effect is set here. Setting range: 0 V to 255 V</p>									

8

HDCP SETTINGS AND EXECUTION

8.1 HDCP settings

<HDCP setting procedure>

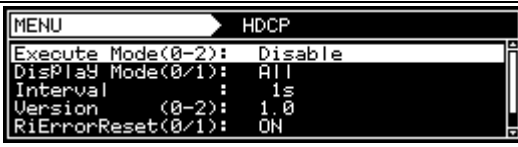
<p>(1) Select Configuration using  or  , and then press .</p>	
<p>(2) Select HDCP using  or  , and then press .</p>	

<List of HDCP setting items>

(1)	Execute Mode (0-2)	<p>The HDCP execution mode is set here.</p> <table border="1"> <tr> <td>0</td> <td>Disable</td> <td>HDCP execution is disabled.</td> </tr> <tr> <td>1</td> <td>Enable</td> <td>HDCP execution is enabled.</td> </tr> <tr> <td>2</td> <td>Program</td> <td>HDCP execution enable/disable is set for each program.</td> </tr> </table>	0	Disable	HDCP execution is disabled.	1	Enable	HDCP execution is enabled.	2	Program	HDCP execution enable/disable is set for each program.
0	Disable	HDCP execution is disabled.									
1	Enable	HDCP execution is enabled.									
2	Program	HDCP execution enable/disable is set for each program.									
(2)	Display Mode (0-1)	<p>The HDCP authentication screen display mode is set here.</p> <table border="1"> <tr> <td>0</td> <td>All</td> <td>All the authentication values are displayed.</td> </tr> <tr> <td>1</td> <td>NG Only</td> <td>The authentication values are displayed only with an NG result.</td> </tr> </table>	0	All	All the authentication values are displayed.	1	NG Only	The authentication values are displayed only with an NG result.			
0	All	All the authentication values are displayed.									
1	NG Only	The authentication values are displayed only with an NG result.									
(3)	Interval	<p>The interval for performing the authentication is set here.</p> <table border="1"> <tr> <td>1s-10s</td> <td></td> <td>An interval from 1 second to 10 seconds is set.</td> </tr> </table>	1s-10s		An interval from 1 second to 10 seconds is set.						
1s-10s		An interval from 1 second to 10 seconds is set.									
(4)	Version (0-2)	<p>The HDCP version is set here.</p> <table border="1"> <tr> <td>0</td> <td>1.0</td> <td>HDCP version 1.0 is used for execution.</td> </tr> <tr> <td>1</td> <td>1.1/1.2</td> <td>Operation is performed using HDCP version 1.1 or 1.2. *1</td> </tr> <tr> <td>2</td> <td>EDID Check</td> <td>The version is determined after checking EDID.</td> </tr> </table>	0	1.0	HDCP version 1.0 is used for execution.	1	1.1/1.2	Operation is performed using HDCP version 1.1 or 1.2. *1	2	EDID Check	The version is determined after checking EDID.
0	1.0	HDCP version 1.0 is used for execution.									
1	1.1/1.2	Operation is performed using HDCP version 1.1 or 1.2. *1									
2	EDID Check	The version is determined after checking EDID.									
(5)	RiErrorReset (0/1)	<p>Whether to proceed with re-authentication when errors have occurred in HDCP authentication is set here. *2</p> <table border="1"> <tr> <td>0</td> <td>OFF</td> <td>Re-authentication is not undertaken when errors have occurred.</td> </tr> <tr> <td>1</td> <td>ON</td> <td>Re-authentication is undertaken when errors have occurred.</td> </tr> </table>	0	OFF	Re-authentication is not undertaken when errors have occurred.	1	ON	Re-authentication is undertaken when errors have occurred.			
0	OFF	Re-authentication is not undertaken when errors have occurred.									
1	ON	Re-authentication is undertaken when errors have occurred.									
(6)	FIFO Ready (0-8)	<p>The limit on the time to wait until "FIFO Ready" is returned when the connected device is a repeater is set here.</p> <table border="1"> <tr> <td>0</td> <td>OFF</td> <td>30 seconds</td> </tr> <tr> <td>1-7</td> <td>600 ms to 4,200 ms</td> <td>Increased in increments of 600 ms</td> </tr> <tr> <td>8</td> <td>5,000 ms</td> <td>5 seconds</td> </tr> </table>	0	OFF	30 seconds	1-7	600 ms to 4,200 ms	Increased in increments of 600 ms	8	5,000 ms	5 seconds
0	OFF	30 seconds									
1-7	600 ms to 4,200 ms	Increased in increments of 600 ms									
8	5,000 ms	5 seconds									
(7)	Wait Time	<p>Delay the time to start first HDCP recognition. (available only for HDMI 300MHz unit VM-1823)</p> <table border="1"> <tr> <td>0ms-200ms</td> <td></td> <td>Set delay time by 10ms unit.</td> </tr> </table>	0ms-200ms		Set delay time by 10ms unit.						
0ms-200ms		Set delay time by 10ms unit.									

*1 "Advance Cipher/Enhanced Link Verification" is not supported.

*2 HDMI 300MHz unit (VM-1823) is always set as ON.

8.2 HDCP execution

8.2.1 Execution procedure

One of the following three steps can be taken for HDCP execution.















- Set enable or disable using the On/Off customize key.
- Set enable or disable using Configuration.**
- Set enable or disable for each program.

a) Setting enable or disable using the On/Off customize key

This setting is canceled when the program is changed, and **b) Setting enable or disable always using Configuration** and **c) Setting enable or disable for each program** take effect.

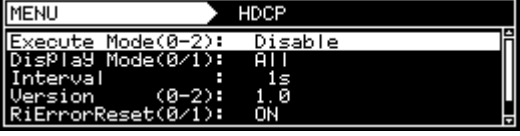































(1)		HDCP is executed, and the authentication results screen appears above the test pattern.
-----	---	---

b) Setting enable or disable using Configuration

(1)	<p>Select Configuration using  →  or  INC  DEC, and then press .</p>										
(2)	<p>Select HDCP using  or  INC  DEC, and then press .</p>										
(3)	<p>Select Execute Mode using  or  INC  DEC, and then press .</p>	<p>The HDCP execution mode is set here.</p> <table border="1"> <tr> <td>0</td> <td>Disable</td> <td>HDCP execution is disabled.</td> </tr> <tr> <td>1</td> <td>Enable</td> <td>HDCP execution is enabled.</td> </tr> <tr> <td>2</td> <td>Program</td> <td>HDCP execution enable/disable is set for each program.</td> </tr> </table>	0	Disable	HDCP execution is disabled.	1	Enable	HDCP execution is enabled.	2	Program	HDCP execution enable/disable is set for each program.
0	Disable	HDCP execution is disabled.									
1	Enable	HDCP execution is enabled.									
2	Program	HDCP execution enable/disable is set for each program.									

c) Setting enable or disable for each program

This setting takes effect when “Program” was selected as the HDCP mode setting in **b) Setting enable or disable using Configuration**.

(1)	<p>Select Program Edit using  →  or  INC  DEC, and then press .</p>																									
(2)	<p>Select Output (TIM) using  or  INC  DEC, and then press .</p>																									
(3)	<p>Select All Output using  or  INC  DEC, and then press .</p>																									
(4)	<p>Select HDCP using  or  INC  DEC, and then press .</p>																									
(5)	<p>Select the items using  or  INC  DEC, and then press .</p>	<p>Execute Enable (0/1) This selects whether HDCP is to be executed. It covers all the video interfaces capable of executing HDCP. HDCP is executed at the same time.</p> <table border="1" data-bbox="863 1077 1485 1144"> <tr> <td>0</td> <td>Disable</td> <td>HDCP is not executed.</td> </tr> <tr> <td>1</td> <td>Enable</td> <td>HDCP is executed.</td> </tr> </table>	0	Disable	HDCP is not executed.	1	Enable	HDCP is executed.																		
0	Disable	HDCP is not executed.																								
1	Enable	HDCP is executed.																								
	<p><Inputting the parameters></p> <p>Select the parameters using  or  INC  DEC, and then press .</p> <p>Alternatively: Select the parameters using the number keys  ( to ), and then press .</p>	<p>Display Select (0-4) <input type="checkbox"/> This item allows the HDCP authentication status to be displayed for one video interface system only.</p> <table border="1" data-bbox="863 1234 1485 1639"> <tr> <td>0</td> <td>Disable</td> <td>The status is not displayed.</td> </tr> <tr> <td>1</td> <td>HDMI1</td> <td>The status of HDMI unit channel 1 is displayed.</td> </tr> <tr> <td>2</td> <td>HDMI2</td> <td>The status of HDMI unit channel 2 is displayed.</td> </tr> <tr> <td>3</td> <td>DP1</td> <td>The status of DP unit channel 1 is displayed.</td> </tr> <tr> <td>4</td> <td>DP2</td> <td>The status of DP unit channel 2 is displayed.</td> </tr> <tr> <td>5</td> <td>DVI2</td> <td>The status of DVI unit channel 2 is displayed.</td> </tr> <tr> <td>6</td> <td>PC-DVI</td> <td>The status of PC unit DVI is displayed.</td> </tr> <tr> <td>7</td> <td>TV-DVI</td> <td>The status of TV unit DVI is displayed.</td> </tr> </table>	0	Disable	The status is not displayed.	1	HDMI1	The status of HDMI unit channel 1 is displayed.	2	HDMI2	The status of HDMI unit channel 2 is displayed.	3	DP1	The status of DP unit channel 1 is displayed.	4	DP2	The status of DP unit channel 2 is displayed.	5	DVI2	The status of DVI unit channel 2 is displayed.	6	PC-DVI	The status of PC unit DVI is displayed.	7	TV-DVI	The status of TV unit DVI is displayed.
0	Disable	The status is not displayed.																								
1	HDMI1	The status of HDMI unit channel 1 is displayed.																								
2	HDMI2	The status of HDMI unit channel 2 is displayed.																								
3	DP1	The status of DP unit channel 1 is displayed.																								
4	DP2	The status of DP unit channel 2 is displayed.																								
5	DVI2	The status of DVI unit channel 2 is displayed.																								
6	PC-DVI	The status of PC unit DVI is displayed.																								
7	TV-DVI	The status of TV unit DVI is displayed.																								

8.2.2 Screen displays during HDCP execution

The authentication results and other information are displayed on the screen during HDCP execution.
(If other patterns are already displayed, the information will be displayed on top of the patterns.)

- (1) When HDCP is selected as the NAME/LIST pattern.

For details on the screen and what is displayed on the screen, refer to “6.13.5 HDCP (High-bandwidth Digital Content Protection).”

- (2) At all other times

A screen such as the one shown below is displayed.

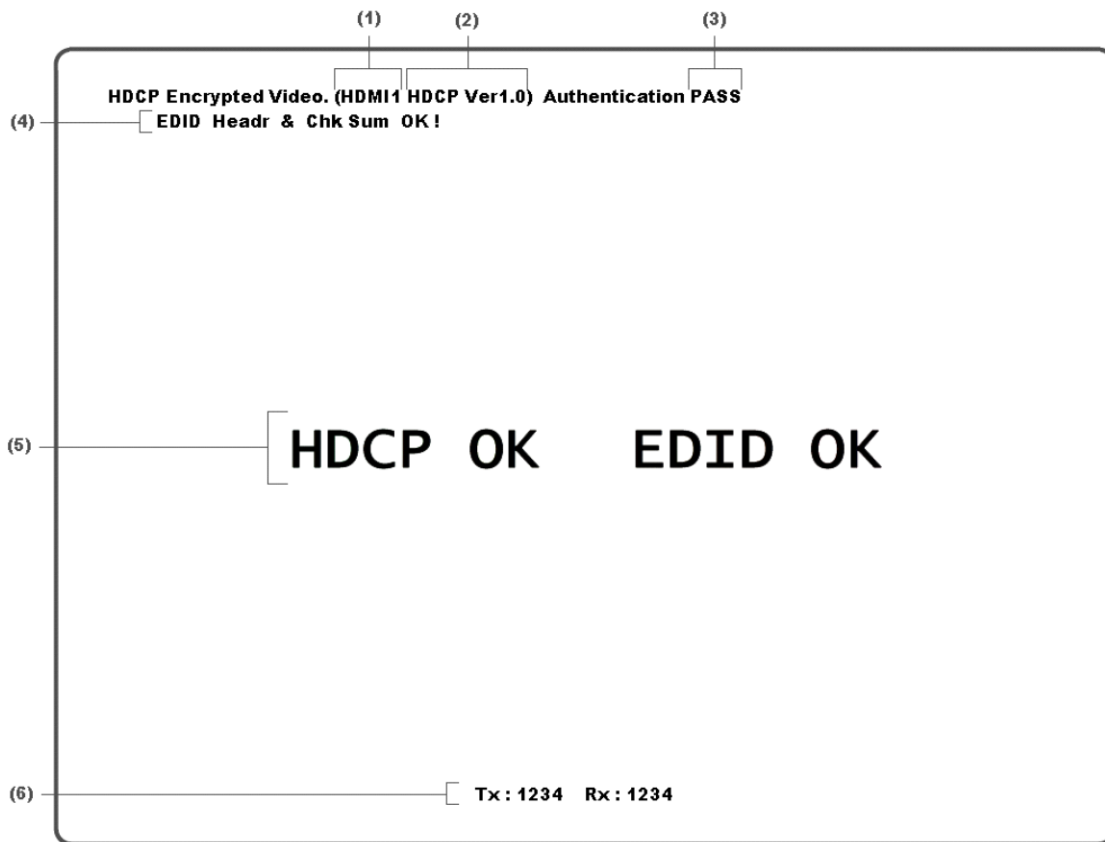

Details of the information shown on the screen are given below.

<HDCP authentication screen (simplified version) display data>











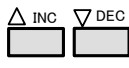

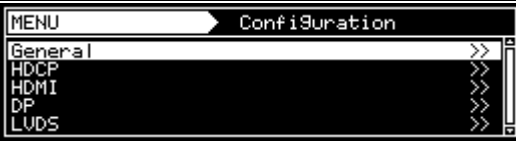

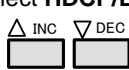

(1)	This indicates the port selected in c) Display Select of “ 8.2.1 Execution procedure. ”												
(2)	The HDCP version is displayed here. (When the HDCP authentication has failed, an error message is displayed.)												
(3)	The HDCP authentication results are displayed here. (If authentication is successful, “PASS” appears; it has failed, “NG” appears.)												
(4)	The check results for the EDID header and checksum are indicated here. (These results are displayed only when “ AUTO ” has been selected as the HDMI or DVI setting in “ 4.2.2 HDMI setting procedure ” or when “ EDID Check ” has been selected as the Version setting in “ 8.1 HDCP settings. ”)												
(5)	The HDCP authentication status (OK or NG) as well as the check result (OK or NG) for the EDID header and checksum are indicated here. (These results are displayed only when “ AUTO ” has been selected as the HDMI or DVI setting in “ 4.2.2 HDMI setting procedure ” or when “ EDID Check ” has been selected as the Version setting in “ 8.1 HDCP settings. ”)												
(6)	<p>The Synchronization Verification Values for checking the adequacy of the link are displayed here. “Tx” is the value calculated for the transmitter; “Rx” is the value calculated for the receiver. The display is updated each time HDCP authentication and encryption are completed. * When the HDCP display is DisplayPort, this item is not displayed.</p> <p>In the HDCP/EDID/CEC collective display mode, the following check results are displayed in addition to the above displays.</p> <table border="1" data-bbox="472 922 1348 1019"> <tr> <td>HDCP:</td> <td>DVI-2: OK</td> <td>HDMI1: OK</td> <td>HDMI2: NG</td> </tr> <tr> <td>CEC:</td> <td></td> <td>HDMI1: OK</td> <td>HDMI2: OK</td> </tr> <tr> <td>EDID:</td> <td>DVI-1: OK DVI-2: OK TvVGA1: OK</td> <td>HDMI1: OK</td> <td>HDMI2: OK</td> </tr> </table> <p style="text-align: center;">Display example (DVI + TV + HDMI)</p> <p>For details of the HDCP/EDID/CEC collective display mode settings, refer to section “8.2.3 HDCP/EDID/CEC collective display.”</p> <p>* The requisite license must be registered. To purchase the license, consult with an ASTRODESIGN sales representative or your distributor.</p>	HDCP:	DVI-2: OK	HDMI1: OK	HDMI2: NG	CEC:		HDMI1: OK	HDMI2: OK	EDID:	DVI-1: OK DVI-2: OK TvVGA1: OK	HDMI1: OK	HDMI2: OK
HDCP:	DVI-2: OK	HDMI1: OK	HDMI2: NG										
CEC:		HDMI1: OK	HDMI2: OK										
EDID:	DVI-1: OK DVI-2: OK TvVGA1: OK	HDMI1: OK	HDMI2: OK										

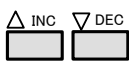
8.2.3 HDCP/EDID/CEC collective display







* The requisite license must be registered. To purchase the license, consult with an ASTRODESIGN sales representative or your distributor.

When OFF has been selected as the List display setting, the results of the HDCP/EDID/CEC check can be displayed together with HDCP ON.

■ OK/NG Display Mode settings

<p>(1) Select Configuration using  or , and then press .</p>							
<p>(2) Select HDCP/EDID/CEC Check using  or , and then press .</p>							
<p>(3) Select OK/NG Display Mode using  or , and then press .</p>							
<p><Inputting the parameters></p> <p>Select the parameters using  or , and then press .</p> <p>Alternatively: Select the parameters using the number keys ( to ) , and then press .</p>	<p>Select the OK/NG Display Mode setting.</p> <table border="1" data-bbox="750 1097 1372 1332"> <tr> <td>0</td> <td>Standard</td> <td>This is the standard display.</td> </tr> <tr> <td>1</td> <td>Collective</td> <td>This is the collective display. The results of the checks of the items selected by Item Select are displayed collectively.</td> </tr> </table>	0	Standard	This is the standard display.	1	Collective	This is the collective display. The results of the checks of the items selected by Item Select are displayed collectively.
0	Standard	This is the standard display.					
1	Collective	This is the collective display. The results of the checks of the items selected by Item Select are displayed collectively.					

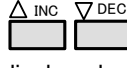
■ Item Select settings

<p>(1) Select Item Select using  or , and then press .</p>	 <p>When Collective is selected as the OK/NG Display Mode setting, the Item Select item appears on the next line.</p>
<p>(2) Using  or , select the items to be collectively displayed, and then press .</p>	 <p>* The item differs depending on the optional board installed.</p>

<OK or NG judgment>

(1) HDCP

With HDCP ON, it is checked that HDCP authentication is performed correctly.

(2) EDID

The EDID is read at specific intervals, and an "OK" verdict is given when:

- The EDID can be read correctly.
- The EDID header and checksum are correct.

(3) CEC

An OK verdict is given if the CEC commands are sent in succession to the HDMI ports and ACK responses are given correctly when the program is run.

For the CEC send data and parameters, refer to the CEC List data among the program data.

The CEC check is performed if the following conditions are met:

- Transmission must be established as the Mode setting.
- The Tx Destination must be other than Fh.

If the above conditions are not met, the CEC check is not performed. (No displays will be shown.)

<Items which can be displayed collectively>

The items listed in the table below can be displayed collectively.

Output unit	HDCP		EDID		CEC	
PC analog unit VM-1811	PcDVI1 PcDVI2 PcDVI3		PcDVI1 PcDVI2 PcDVI3	PcVGA1 PcVGA2 PcVGA3		
TV encoder unit VM-1812, VM-1812-B			TvVGA1 TvVGA2 TvVGA3			
DVI unit VM-1814		DVI-2 DVI-4 DVI-6	DVI-1 DVI-3 DVI-5	DVI-2 DVI-4 DVI-6		
HDMI unit VM-1817, VM-1822 VM-1823	HDMI1 HDMI3 HDMI5	HDMI2 HDMI4 HDMI6	HDMI1 HDMI3 HDMI5	HDMI2 HDMI4 HDMI6	HDMI1 HDMI3 HDMI5	HDMI2 HDMI4 HDMI6
Display port unit VM-1820	DP-1 DP-3 DP-5	DP-2 DP-4 DP-6	DP-1 DP-3 DP-5	DP-2 DP-4 DP-6		

* The settings of the second and third boards are set for the second and third slots of the columns.

















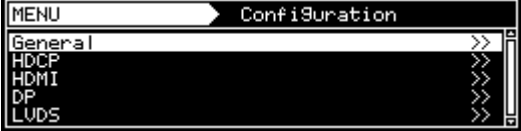





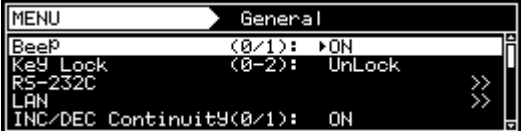



9

VG-870B/871B/873/874 SYSTEM SETTINGS

9.1 System settings

9.1.1 Beep setting



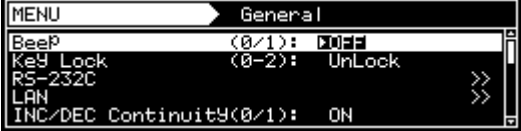







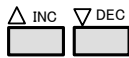

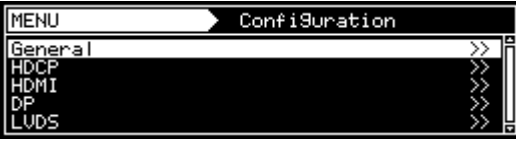

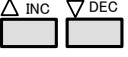

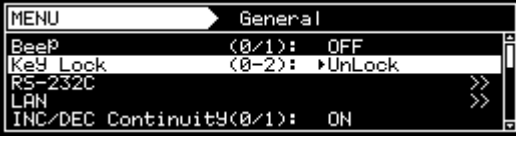

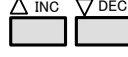
The buzzer which sounds when any of the keys on the front panel of the VG-870B/873 (or on the RB-1870 or RB-1871) are pressed can be turned on or off.

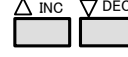
(1)	<p>Select Configuration using    or  INC  DEC , and then press .</p>							
(2)	<p>Select General using  or  INC  DEC , and then press .</p>							
	<p>Select Beep using  or  INC  DEC , and then press .</p> <p><Inputting the parameters></p> <p>Select the parameters using  or  INC  DEC , and then press .</p> <p>Alternatively: Select the parameters using the number keys ( to ), and then press .</p>	 <p>Whether the buzzer is to beep is set here.</p> <table border="1" data-bbox="863 1144 1497 1391"> <tr> <td data-bbox="863 1144 890 1178">0</td> <td data-bbox="890 1144 1062 1178">OFF</td> <td data-bbox="1062 1144 1497 1178">The buzzer is turned off.</td> </tr> <tr> <td data-bbox="863 1178 890 1211">1</td> <td data-bbox="890 1178 1062 1211">ON</td> <td data-bbox="1062 1178 1497 1211">The buzzer is turned on.</td> </tr> </table>	0	OFF	The buzzer is turned off.	1	ON	The buzzer is turned on.
0	OFF	The buzzer is turned off.						
1	ON	The buzzer is turned on.						

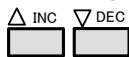

9.1.2 Key lock setting

The keys on the VG-870B/871B/873/874 main unit can be locked.

<Key lock setting>

<p>(1) Select Configuration using  or , and then press .</p>	
<p>(2) Select General using  or , and then press .</p>	
<p>(3) Select Key Lock using  or . Select the setting using  or , and then press . Alternatively: Select the setting using the number keys ( to ).</p>	<p>UnLock: Key lock is not set.</p> <p>Lock: The keys set by the SP-8870 are locked. * For details on the settings, refer to the instruction manual of the SP-8870 software.</p> <p>ALL Lock: All the keys are locked.</p>
<p>(4) Call the SAVE menu using . Select Configuration Data SAVE using  or , and then press . After saving the data, the key lock setting takes effect when the power is turned off and then turned back on.</p>	



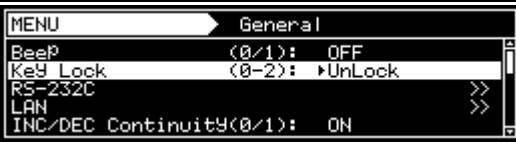







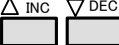

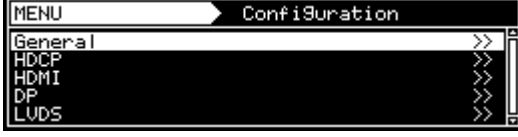

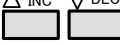

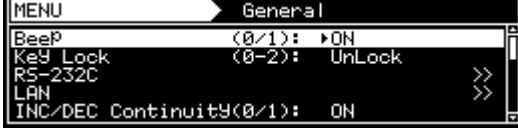

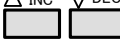
<Key lock release and unlock settings>

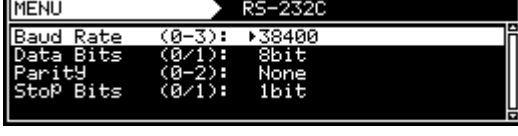
<p>(1) After performing the key lock setting, the setting takes effect when the power of the generator is turned on. To release the key lock setting: Press  for about 5 seconds. Key lock is released, and MENU is opened.</p>	
<p>(2) Save the Unlock setting by following steps (1) to (4) for the key lock setting.</p>	

* Unless the Unlock setting is saved, the key lock setting will take effect when the generator is turned on.

9.1.3 RS-232C settings

These settings are performed when connection to the terminal is to be established from the RS-232C port.











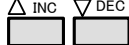

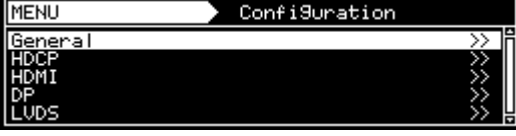



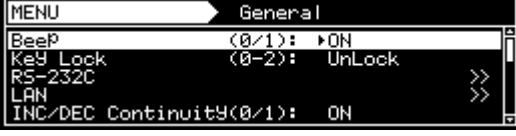

(1)	<p>Select Configuration using  or , and then press .</p>																																		
(2)	<p>Select General using  or , and then press .</p>																																		
(3)	<p>Select RS232C using  or , and then press .</p>																																		
(4)	<p><Inputting the parameters></p> <p>Select the parameters using  or , , and then press .</p> <p>Alternatively: Select the parameters using the number keys , , and then press .</p>	<p>The baud rate is set here.</p> <table border="1" data-bbox="861 869 1492 1003"> <tr><td>0</td><td>9600</td><td>The baud rate is set to 9600 bps.</td></tr> <tr><td>1</td><td>19200</td><td>The baud rate is set to 19200 bps.</td></tr> <tr><td>2</td><td>38400</td><td>The baud rate is set to 38400 bps.</td></tr> <tr><td>3</td><td>57600</td><td>The baud rate is set to 57600 bps.</td></tr> </table> <p>The number of data bits is set here.</p> <table border="1" data-bbox="861 1037 1492 1104"> <tr><td>0</td><td>7 bit</td><td>7 data bits are set</td></tr> <tr><td>1</td><td>8 bit</td><td>8 data bits are set</td></tr> </table> <p>The parity is set here.</p> <table border="1" data-bbox="861 1137 1492 1238"> <tr><td>0</td><td>None</td><td>Parity is set to none.</td></tr> <tr><td>1</td><td>Even</td><td>Parity is set to even.</td></tr> <tr><td>2</td><td>Odd</td><td>Parity is set to odd.</td></tr> </table> <p>The number of stop bits is set here.</p> <table border="1" data-bbox="861 1272 1492 1339"> <tr><td>0</td><td>1 bit</td><td>1 stop bit is set.</td></tr> <tr><td>1</td><td>2 bit</td><td>2 stop bits are set.</td></tr> </table>	0	9600	The baud rate is set to 9600 bps.	1	19200	The baud rate is set to 19200 bps.	2	38400	The baud rate is set to 38400 bps.	3	57600	The baud rate is set to 57600 bps.	0	7 bit	7 data bits are set	1	8 bit	8 data bits are set	0	None	Parity is set to none.	1	Even	Parity is set to even.	2	Odd	Parity is set to odd.	0	1 bit	1 stop bit is set.	1	2 bit	2 stop bits are set.
0	9600	The baud rate is set to 9600 bps.																																	
1	19200	The baud rate is set to 19200 bps.																																	
2	38400	The baud rate is set to 38400 bps.																																	
3	57600	The baud rate is set to 57600 bps.																																	
0	7 bit	7 data bits are set																																	
1	8 bit	8 data bits are set																																	
0	None	Parity is set to none.																																	
1	Even	Parity is set to even.																																	
2	Odd	Parity is set to odd.																																	
0	1 bit	1 stop bit is set.																																	
1	2 bit	2 stop bits are set.																																	

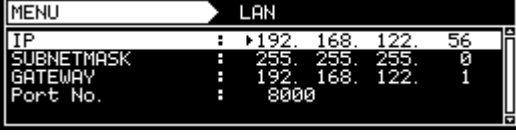

- When you use terminal commands for VG-870 series, please set "Data Bits" as 8-bit. If you use old VG series (e.g. VG-848, VG-859C), some commands works okay with Data Bits as 7-bit.
- When you change setting here, please re-boot VG unit. The setting change is activated after re-booting.

9.1.4 LAN settings

These settings are performed when connection to the terminal is to be established from the LAN port.





















<p>(1) Select Configuration using  or , and then press .</p>																	
<p>(2) Select General using  or , and then press .</p>																	
<p>(3) Select LAN using  or , and then press .</p>																	
<p>(4) <Inputting the parameters> Select the parameters using  or , , and then press . Alternatively: Select the parameters using the number keys  ( to ), and then press .</p>	<table border="1"> <tbody> <tr> <td colspan="2">The IP is set here.</td> </tr> <tr> <td>xxx.xxx.xxx.xxx</td> <td>Set the IP address. The factory setting is 192.168.0.2.</td> </tr> <tr> <td colspan="2">The SUBNETMASK is set here.</td> </tr> <tr> <td>xxx.xxx.xxx.xxx</td> <td>Set the subnetmask address. The factory setting is 255. 255. 255.0.</td> </tr> <tr> <td colspan="2">The GATEWAY is set here.</td> </tr> <tr> <td>xxx.xxx.xxx.xxx</td> <td>Set the gateway address. The factory setting is 192. 168. 122.1.</td> </tr> <tr> <td colspan="2">The Port No. is set here.</td> </tr> <tr> <td>xxxx</td> <td>Set the number of the port to be used by the terminal commands. The factory setting is 8000.</td> </tr> </tbody> </table>	The IP is set here.		xxx.xxx.xxx.xxx	Set the IP address. The factory setting is 192.168.0.2.	The SUBNETMASK is set here.		xxx.xxx.xxx.xxx	Set the subnetmask address. The factory setting is 255. 255. 255.0.	The GATEWAY is set here.		xxx.xxx.xxx.xxx	Set the gateway address. The factory setting is 192. 168. 122.1.	The Port No. is set here.		xxxx	Set the number of the port to be used by the terminal commands. The factory setting is 8000.
The IP is set here.																	
xxx.xxx.xxx.xxx	Set the IP address. The factory setting is 192.168.0.2.																
The SUBNETMASK is set here.																	
xxx.xxx.xxx.xxx	Set the subnetmask address. The factory setting is 255. 255. 255.0.																
The GATEWAY is set here.																	
xxx.xxx.xxx.xxx	Set the gateway address. The factory setting is 192. 168. 122.1.																
The Port No. is set here.																	
xxxx	Set the number of the port to be used by the terminal commands. The factory setting is 8000.																

CAUTION

- When you change setting here, please re-boot VG unit. The setting change is activated after re-booting.















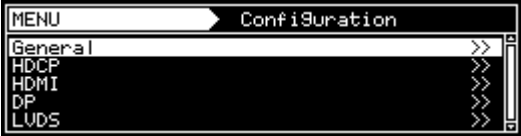

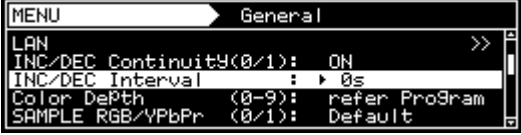

9.1.5 INC/DEC continuity setting

The INC/DEC key continuity function enables the holding down of the INC and DEC keys to be enabled or disabled. It works only when programs are selected and executed.

<p>(1) Select Configuration using  →  or  , and then press .</p>	
<p>(2) Select General using  or  , and then press .</p>	
<p>(3) Select INC/DEC Continuity using  or  .</p> <p>Select ON or OFF using  or  , and then press .</p> <p>Alternatively, select ON or OFF using the number keys ( to ).</p>	<p>ON: Programs continue to be switched while the INC or DEC key is held down.</p> <p>OFF: The number of programs switched corresponds to the number of times the INC or DEC key is pressed. Whether the keys are tapped or held down makes no difference.</p> <p>* For the switching intervals, refer to “9.1.6 INC/DEC interval setting.”</p>

9.1.6 INC/DEC interval setting

This function enables the minimum interval for switching programs to be set using the INC and DEC key. It works only when programs are selected and executed.

<p>(1) Select Configuration using  →  or  , and then press .</p>	
<p>(2) Select General using  or  , and then press .</p>	
<p>(3) Select INC/DEC Interval using  or  .</p> <p>Select the value using  or  , and then press .</p> <p>Alternatively, select the value using the number keys ( to ).</p>	<p>Set using a value from 0 s to 10 s. The lower the value, the faster the switching speed.</p>





















9.1.7 Color depth setting

This setting makes it possible to specify whether the number of color gray scale bits for the output images is to accord with the program data or whether it is to be fixed.

For details, refer to “4.1.5 Setting the bit length (gray scale) for pattern drawing.”

















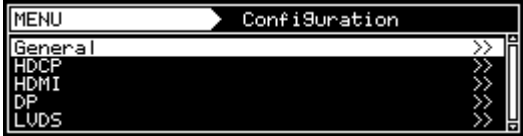





9.1.8 SAMPLE RGB/YPbPr setting

This setting makes it possible to specify whether the color space of the output images is to accord with the sample program data or whether it is to be fixed to RGB.

<p>(1) Select Configuration using  →  or  INC  DEC, and then press .</p>	
<p>(2) Select General using  or  INC  DEC, and then press .</p>	
<p>(3) Select SAMPLE RGB/YPbPr using  or  INC  DEC. Select the value using  or  INC  DEC, and then press . Alternatively, select the value using the number keys ( to ).</p>	<p>Default: Default: RGB/YPbPr is changed in accordance with the color space registered in the sample program data.</p> <p>RGB: The color space is fixed to RGB. Due to the stipulations of the DVI and other standards, the color difference signals are output at the “Default” setting in the event that the EIA timing or other such data of the sample program has been selected for outputs with no color difference signals. However, by selecting “RGB” to fix the color space to RGB, the RGB output can be selected without having to edit the program.</p>

9.1.9 DDC clock setting

The DDC clock can be set.

(1)	<p>Select Configuration using    or  , and then press .</p>	
(2)	<p>Select General using  or  , and then press .</p>	
(3)	<p>Select DDC Clock using  or  .</p> <p>Select the value using  or  , and then press .</p> <p>Alternatively, select the value using the number  keys ( to ).</p>	<p>Select 20, 40, 60, 80 or 100 kHz. The factory setting is 100 kHz.</p>

9.1.10 Trigger mode settings

- Concerning the trigger function

The trigger function outputs trigger in accordance with the patterns in order to evaluate the moving picture response speed and other factors.

The following kinds of triggers are provided.

- (1) Window triggers (TriggerA/TriggerB)
- (2) VSync trigger
- (3) Scroll triggers (optional)
- (4) Simple moving image frame trigger (optional)

(1) Window triggers (TriggerA/TriggerB)

When, on the window patterns, 4 or 16 levels are set and displayed for the format, these triggers are output in accordance with the level sequence.

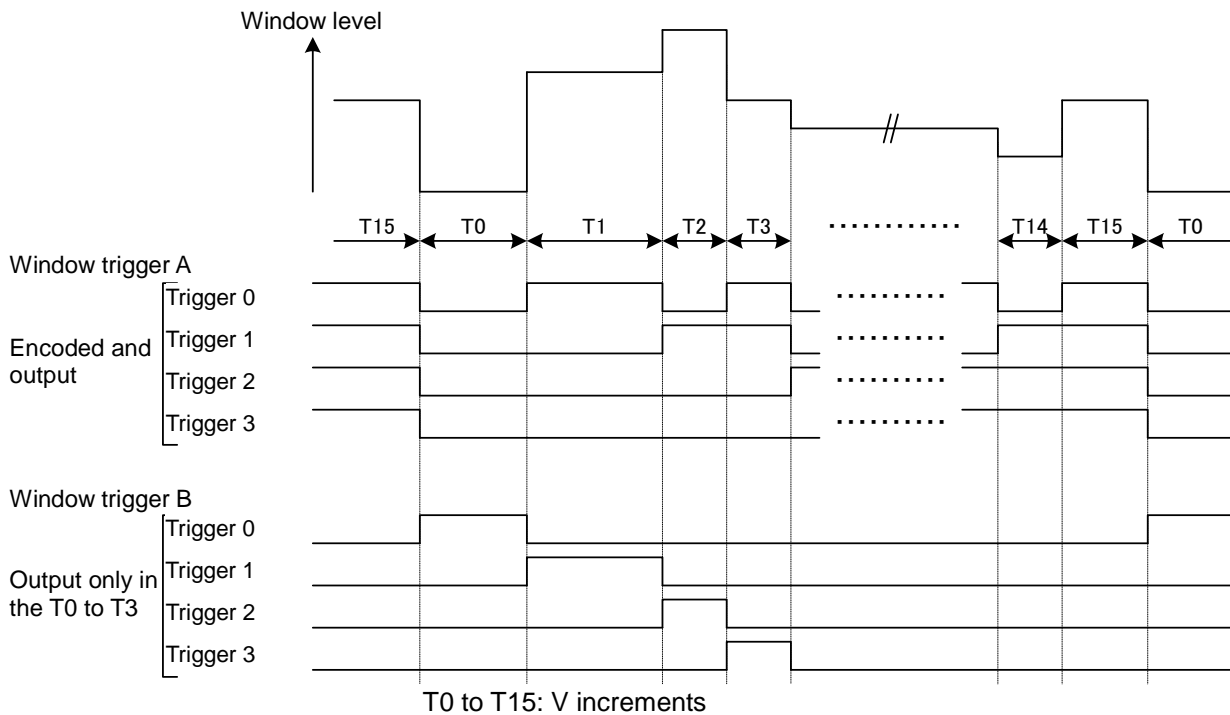

(2) VSync trigger

High and low levels are output alternately in line with VSync.

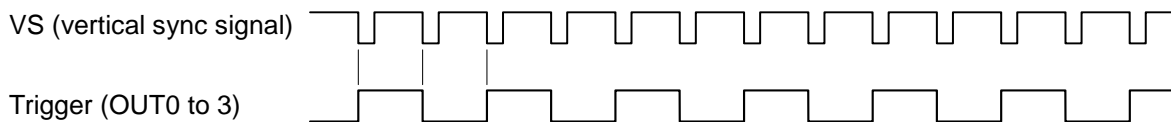

(3) Scroll triggers (optional)

When a pattern is being scrolled, the trigger is output when the pattern has reached the start position.

When scrolling toward the left

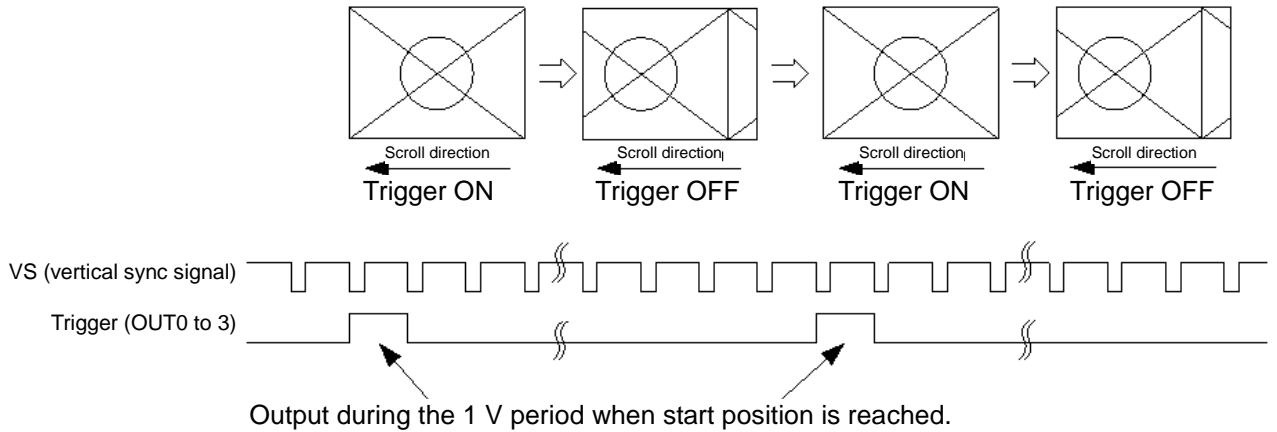

CAUTION

- When there is a multiple number of scroll ON planes (graphic, character and window planes), trigger ON is not output when the scroll settings (step and direction) differ.
- When there is one scroll ON plane, the trigger ON is output in accordance with the settings of that plane.
- Trigger ON can be output with both horizontal direction (left/right) scrolling and vertical direction (up/down) scrolling, but when scrolling in both of these directions (top right, for instance), it is output in accordance with the horizontal direction.





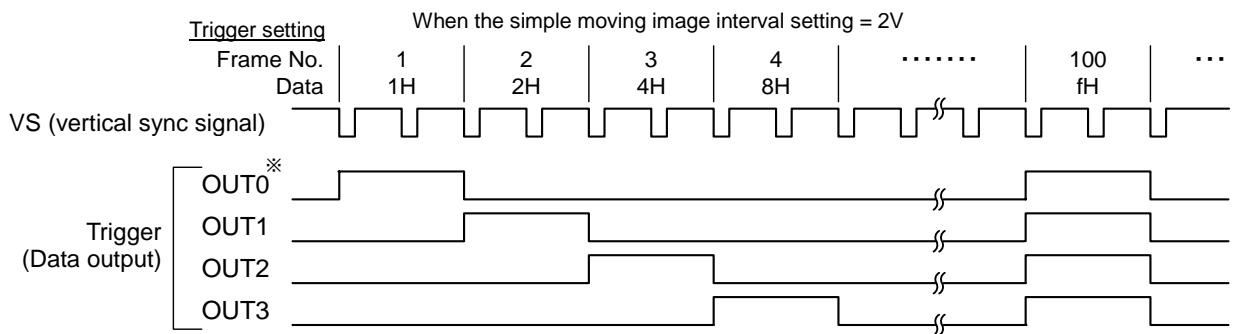









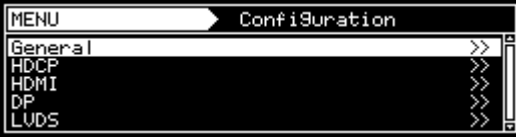



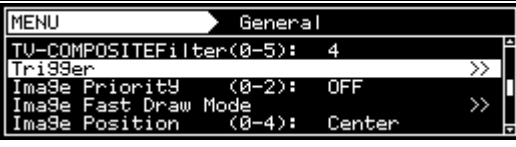



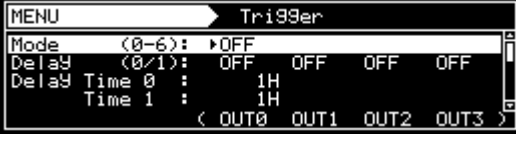

(4) Simple moving image frame trigger (optional)

The trigger is output at the specified frames while simple moving images are displayed.



* The VSync trigger is output for OUT0 when Frame + VSync Trigger has been set as the mode.

<Setting procedure>

(1)	<p>Select Configuration using  →  or  , and then press .</p>	
(2)	<p>Select General using  or  , and then press .</p>	
(3)	<p>Select Trigger using  or  , and then press .</p>	
(4)	<p><Selecting the items> Select the parameters using  or  , and then press .</p> <p><Setting the parameters> Select the parameters using  or  , and then press .</p> <p>Alternatively: Select the parameters using the number keys ( to ), and then press .</p>	<p>For details, refer to <Table of common trigger setting items> and <Table of simple moving image frame trigger setting items>.</p>

<Table of common trigger setting items>

Mode (0-6)	<p>The trigger functions are selected here. * Frame Trigger, Frame+VSync Trigger and Scroll Trigger are optional functions. For further details, contact your dealer or an ASTRODESIGN sales representative.</p>	
0	OFF	At this setting, the trigger output is set to OFF.
1	TriggerA	Window trigger A is output. The trigger is encoded in line with the set time, and output.
2	TriggerB	Window trigger B is output. The trigger is output in line with the set time only for the T0-T3 duration.
3	VSync Trigger	The VSync trigger is output. The trigger is encoded in line with the VSync signal, and output.
4	Frame Trigger *	The simple moving image frame triggers are output. The triggers are output at the specified frames.
5	Frame+VSync Trigger *	The simple moving image frame triggers (OUT1-3) and VSync trigger (OUT0) are output.
6	Scroll Trigger *	The scroll trigger is output. The trigger is output in line with the scroll setting.

Delay (0/1)	ON or OFF for the trigger delay function is selected for each output (OUT0-3).		Delay OFF ON Delay Time	
	0	OFF		The triggers are not delayed.
	1	ON		The trigger outputs are delayed in accordance with the Delay Time .
Delay Time 0, 1	The delay time is set here. Setting range: 1 to 4096 [H]			
	Time Sel (0/1) The delay time settings (Delay Time 0 and 1) are selected here for each output (OUT0 to 3).			
	0	Delay Time 0		
Pulse (0/1)	ON or OFF for the pulse function is selected for each output (OUT0-3).		Pulse OFF ON Triggers other than VSync trigger VSync trigger * Pulse Width	
	0	OFF		The triggers are output using a width in V increments. (Refer to "Concerning the trigger function" described previously.)
	1	ON		The triggers are output using the designated width (in H increments) of the Pulse Width .
Pulse Width 0, 1	The pulse width is set here. Setting range: 0 to 4095 [H]		* When the pulse function is OFF, high-level and low-level VSync triggers are output alternately in line with VSync; when it is ON, they are output with each VSync signal.	
	Width Sel (0/1) The pulse width settings (Pulse Width 0 and 1) are selected here for each output (OUT0 to 3).			
Polarity (0/1)	The polarity of the trigger output is selected for each output (OUT0-3).			
	0	Nega	Reversed	
	1	Posi	Positive (high)	

<Table of simple moving image frame trigger setting items>

* The simple moving image frame trigger is an option so it will not be displayed unless the license has been registered.

Number Of Frames	The number of frames for outputting the trigger is set here. Setting range: 0 to 16
Frame No.	The numbers of the frames (max. 16) for outputting the trigger are set here. Any number which exceeds the number of simple moving image being displayed will be ignored. Setting range: 1 to 1024
Data	The data to be output to the specified frames is set here. (Data bits 0-3: OUT0-3) Setting range: 0x0 to 0xF

<Example of simple animation frame trigger settings>

●EXP.1

V-Sync

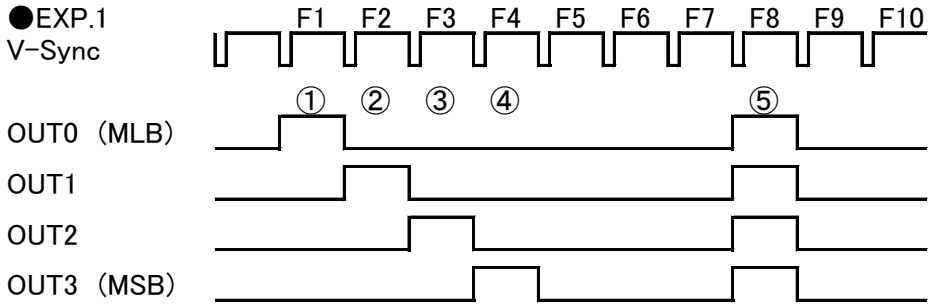

Number Of Fram: 5

	Frame No.	Data
①	1 :	1 1H
②	2 :	2 2H
③	3 :	3 4H
④	4 :	4 8H
⑤	5 :	8 fH

●EXP.2

V-Sync

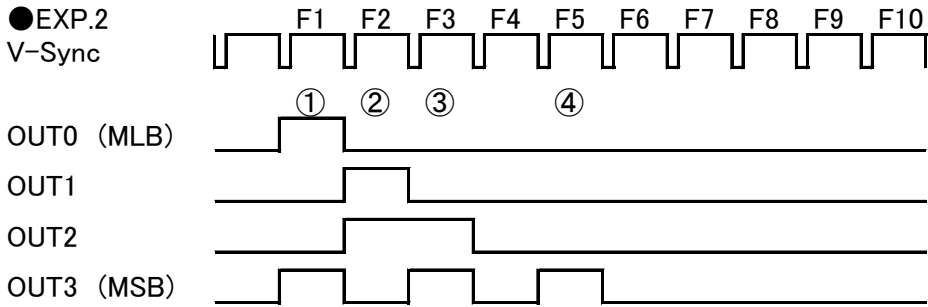

Number Of Fram: 4

	Frame No.	Data
①	1 :	1 9H
②	2 :	2 6H
③	3 :	3 cH
④	4 :	5 8H

●EXP.3
V-Sync

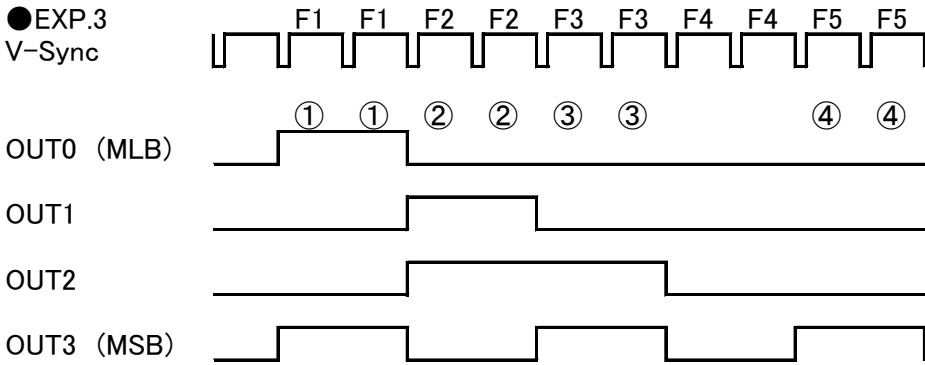

Number Of Fram: 4

	Frame No.	Data
①	1 : 1	9H
②	2 : 2	6H
③	3 : 3	cH
④	4 : 5	8H

○When "2" has been selected as the setting for the interval parameter of simple animation below
 GraphicPlaneScr : Direction : SimpleAnimation
 :Interval1 : 2 (A value of 1 applies for EXP.1 and EXP.2.)

●EXP.4
V-Sync

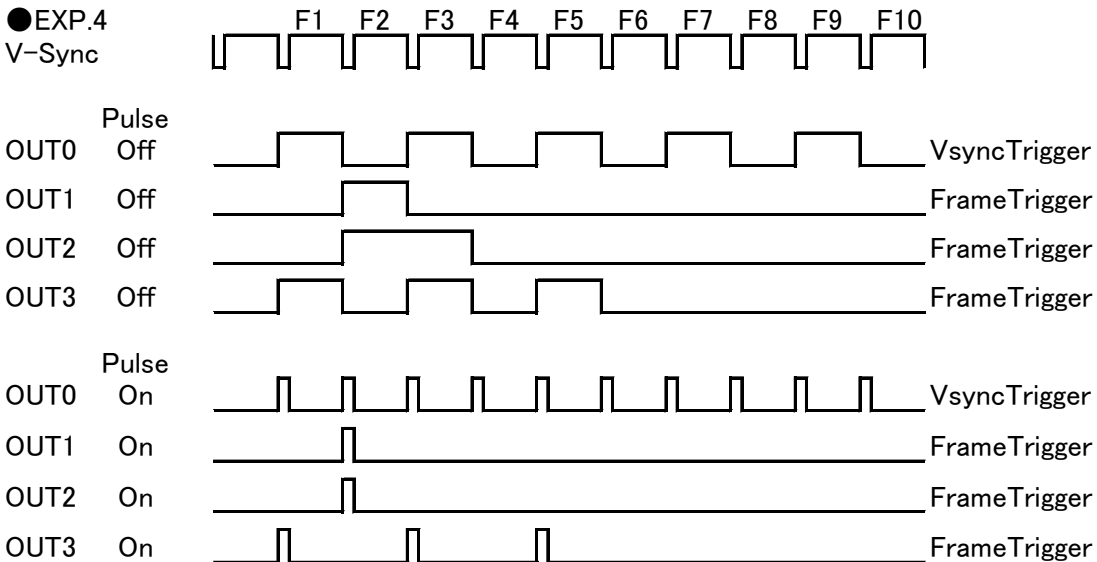

○Under the settings below, VsyncTrigger is output to OUT1 and FrameTrigger to the other ports.
 Mode : Frame+Vsync Trigger

- When Pulse has been set to On, VsyncTrigger pulses are output at both the rising and falling edges.
- When Pulse has been set to On, FrameTrigger pulses are output at the rising edges only.
- A pulse is output only to the initial edge when it spans a multiple number of frames as with OUT2.















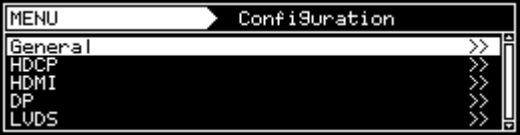

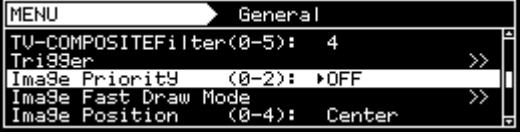

9.1.11 Image - priority settings

Image priority settings can be performed.

Data can be saved both in the internal memory of the VG-870B/871B/873/874 or on CF cards.

This setting is used to set the priority when both sets of image data have been made valid.

















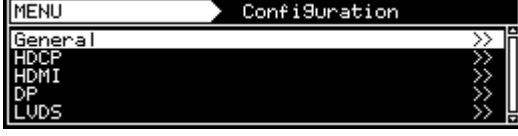

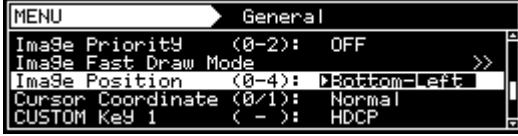

Utilizing it brings some advantages such as increasing the drawing speed and dispersing the data to the internal memory and CF card and then calling the saved data.

(1)	<p>Select Configuration using  →  or  INC  DEC, and then press .</p>	
(2)	<p>Select General using  or  INC  DEC, and then press .</p>	
(3)	<p>Select Image Priority using  or  INC  DEC.</p> <p>Select the setting using  or  INC  DEC, and then press .</p> <p>Alternatively, select the setting using the number keys ( to ).</p>	<p>OFF: When a CF card is inserted, only the image data on the CF card is valid. The image data in the internal memory is invalid.</p> <p>Internal > CF: The image data both in the internal memory and on the CF card are valid. In this mode, reading of the image data in the internal memory takes priority. An increase in the drawing speed can be expected.</p> <p>CF > Internal: The image data both in the internal memory and on the CF card are valid. In this mode, reading of the image data on the CF card takes priority.</p>

9.1.12 Image Position Setting

Image Position setting can change Bitmap's display position.

* **Bitmap resolution can be set only when its resolution is lower than display resolution.**



















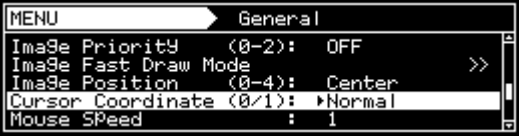

(1)	<p>Select Configuration using   or  INC  DEC , and then press .</p>	
(2)	<p>Select General using  or  INC  DEC, and then press .</p>	
(3)	<p>Select Image Position using  or  INC  DEC.</p> <p>Select the setting using  or  INC  DEC, and then press .</p> <p>Alternatively, select the setting using the number keys ( 0/STATUS to  9/F ).</p>	<p>For further details of the settings, refer to the table below</p>

Key	LCD display	Description
0	Center	The image is displayed at the center of the screen.
1	Top-Left	The image is displayed at the top left of the screen
2	Bottom-Left	The image is displayed at the bottom left of the screen
3	Top-Right	The image is displayed at the top right of the screen
4	Bottom-Right	The image is displayed at the bottom right of the screen

9.1.13 Cursor coordinate setting

The position for displaying the cursor coordinates can be set.

For details on the On or Off setting procedure for the coordinate display, refer to “6.12.1 Cursor settings.”















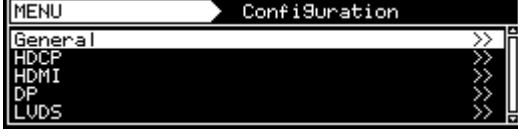

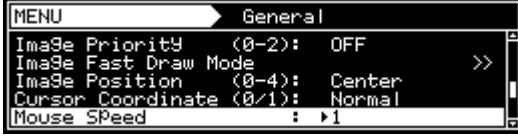

(1)	<p>Select Configuration using    or  , and then press .</p>	
(2)	<p>Select General using  or  , and then press .</p>	
(3)	<p>Select Cursor Coordinate using  or  .</p> <p>Select the setting using  or  , and then press .</p> <p>Alternatively, select the setting using the number keys ( to ).</p>	<p>For details on the settings, refer to the table below.</p>

Key	LCD display	Description
0	Normal	The coordinates are displayed at the top left or top right of the display.
1	Move with Curs	The display appears near the actual cursor coordinates and moves as the cursor moves.

9.1.14 Mouse speed setting





















The movement speed at which to move the cursor using the USB mouse can be set.

For details on the On or Off setting procedure for the coordinate display, refer to “6.12.1 Cursor settings.”

<p>(1) Select Configuration using  or  , and then press .</p>	
<p>(2) Select General using  or  , and then press .</p>	
<p>(3) Select Mouse Speed using  or  .</p> <p>Select the setting using  or  , and then press .</p> <p>Alternatively, select the setting using the number keys ( to ).</p>	<p>Setting range: 0 (fastest) to 9 (slowest) The factory speed setting is “1.”</p>

9.1.15 Digital Video Level Step setting















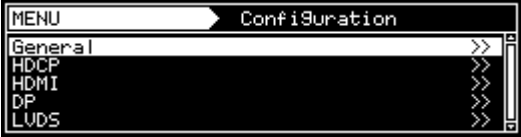



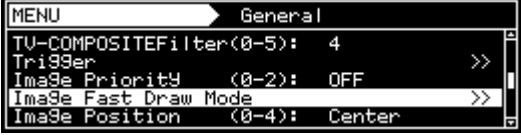

By performing operations to change the digital level of the video signals (refer to section “4.1.8 Setting the digital level”), the number of steps to be taken when the setting speed is increased by pressing the SHIFT key simultaneously is set.

<p>(1) Select Configuration using  →  or  INC  DEC, and then press .</p>	
<p>(2) Select General using  or  INC  DEC, and then press .</p>	
<p>(3) Select DV Level Step (SHIFT) using  or  INC  DEC. Select the setting using  or  INC  DEC, and then press . Alternatively, select the setting using the number keys ( to ).</p>	<p>Setting range: 0 (factory default), 1 - 32767</p> <p>When “0” has been set, the default number of steps which differs depending on the bit length (gray scale) is used. When a value from 1 to 32767 has been set, the number of steps set regardless of the bit length (gray scale) is used.</p>

9.1.16 High-speed drawing mode setting

This function allows high-speed drawing to be set.

With the VG-870B/871B, the high-speed drawing mode in which the specified patterns are selected at high speed can be executed.

<p>(1) Select Configuration using   or  INC  DEC, and then press .</p>											
<p>(2) Select General using  or  INC  DEC, and then press .</p>											
<p>(3) Select Image Fast Draw Mode using  or  INC  DEC, and then press .</p>											
<p>Select the setting using  or  INC  DEC, and then press . Alternatively, select the setting using the number keys ( 0/STATUS to  9/F ).</p>	<p>Select either ON or OFF.</p> <table border="1" data-bbox="857 931 1490 1066"> <tbody> <tr> <td>0</td> <td>OFF</td> <td>The high-speed drawing mode is not executed.</td> </tr> <tr> <td>1</td> <td>ON</td> <td>The high-speed drawing mode is executed.</td> </tr> </tbody> </table> <p>Specify the data numbers of the points at which high-speed drawing is to start and end.</p> <table border="1" data-bbox="857 1111 1490 1254"> <tbody> <tr> <td>Start point</td> <td>Specify a data number from 1 to 200.</td> </tr> <tr> <td>End point</td> <td>* If a number higher than the end point is set for the start point, the start point value will be also applied to the end point.</td> </tr> </tbody> </table>	0	OFF	The high-speed drawing mode is not executed.	1	ON	The high-speed drawing mode is executed.	Start point	Specify a data number from 1 to 200.	End point	* If a number higher than the end point is set for the start point, the start point value will be also applied to the end point.
0	OFF	The high-speed drawing mode is not executed.									
1	ON	The high-speed drawing mode is executed.									
Start point	Specify a data number from 1 to 200.										
End point	* If a number higher than the end point is set for the start point, the start point value will be also applied to the end point.										



























- **Video memory capacity restrictions**
The total volume of data which can be developed in the high-speed pattern selection mode in the image files of the video memory is approximately 174 MB although this figure differs slightly depending on the image data size and other factors. In the high-speed pattern selection mode, it is not possible to load image data exceeding this total.
- **When the CF card has been ejected**
When the high-speed pattern selection mode has been set to ON and image data has been developed from the card into the video memory, all the image data developed from the CF card will be cleared if the card is ejected.

9.1.17 CUSTOM Key1, 2, RB-1871 CUSTOM Key 1, 2

Custom Key2/RB-1871CustomKey2

Either MUTE or HDMI AV-MUTE can be selected.





















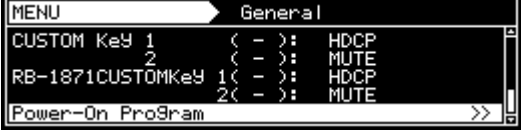



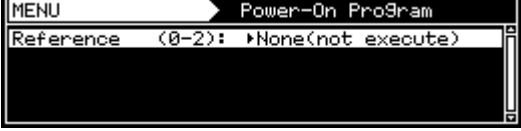







(1)	<p>Select Configuration using  →  or  INC  DEC, and then press .</p>	
(2)	<p>Select General using  or  INC  DEC, and then press .</p>	
(3)	<p>By using  or  INC  DEC, select Parameter. →  .</p> <p>《Parameter setting》</p> <p>By using  or  INC  DEC, select parameter →  .</p> <p>Or, by using number keys  to , select parameters → .</p>	<p>Refer to <<Custom key setting item list>> for details.</p> <p>MUTE: This operates as the audio mute.</p> <p>HDMI AV-MUTE: This operates as the HDMI Av-Mute. It is set to Off when the program is switched.</p> <p>* When the setting is changed, MUTE or HDMI AV-MUTE is set to Off.</p>

《 Custom key setting item list 》

Custom Key1 (0/1)	Set Custom Key1		
	0	HDCP	Operates HDCP Enable/Disable.
	1	SIG ON	SIG ON Key Note) this is valid only VM-1826 is installed.
Custom Key2 (0-2)	Set Custom Key2		
	0	MUTE	Audio Mute
	1	HDMI AV-MUTE	HDMI AV-Mute If you change program, it becomes OFF. Note) if you change setting value, MUTE/HDMI AV-MUTE becomes OFF.
	2	SIG ON	SIG ON key Note) this is valid only VM-1826 is installed.

9.1.18 Operation mode at power-on

The program to be executed immediately after turning on the power of the VG-870B/871B/873/874 can be set.

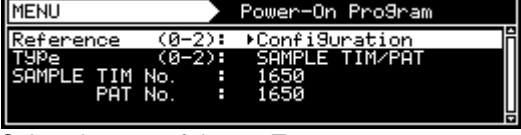
(1)	<p>Select Configuration using    or  , and then press .</p>	
(2)	<p>Select General using  or  , and then press .</p>	
(3)	<p>Select Power-On-Program using  or  , and then press .</p>	
(4)	<p>Select the setting using  or  , and then press .</p> <p>Alternatively: Select the setting using the number keys   ( to ), and then press .</p>	<p><Reference> None (not execute): The program is not executed when the generator's power is turned on.</p> <p>Configuration: The program which was set in step (5) is executed.</p> <p>Last Memory: The Last Memory operation (the program which was executed immediately before the generator's power was turned off) is executed. However, some restrictions apply. Refer to * below.</p>
(5)	<p><When Configuration has been selected> Select the setting using  or  , and then press .</p> <p>Alternatively: Select the setting using the number keys   ( to ), and then press .</p>	 <p>Select the type of data at Type.</p> <p><Type> SAMPLE TIM/PAT: Internal sample data (timing data or pattern data)</p> <p>USER Program: Program data created and registered by the user</p> <p>Group: Group data created and registered by the user</p>











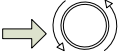







* **Last Memory restrictions**

1. The user program will be executed in cases where the data types differ such as when internal sample data is selected as the timing data and a user program is selected as the pattern data. (Example: When TIM=1001 and PAT=1, TIM=PAT=1 is executed.)
2. The timing data number will be executed in cases where user programs are selected as both the timing data and pattern data but their numbers differs. (Example: When TIM=5 and PAT=1, TIM=PAT=5 is executed.)
3. When Last Memory is executed using a group, the data at the head of the group will be executed.

9.1.19 CF Prg FolderNo. setting

Folders for the program data on the CF cards can be set.















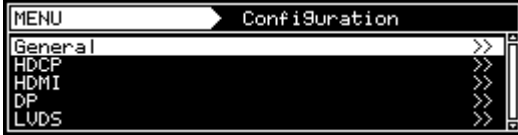



When program data is read and registered, the folders set here are used.

(1)	<p>Select Configuration using  →  or  , and then press .</p>	
(2)	<p>Select General using  or  , and then press .</p>	
(3)	<p>Select CF Prg FolderNo. using  or  .</p> <p>Select the setting using  or  , and then press .</p> <p>Alternatively, select the setting using the number keys ( to ).</p>	<p>Setting range: 0 (factory default), 1 - 999</p>

9.1.20 AVMUTE operation mode settings

It is possible to select the method used to set the Set_AVMUTE and Clear_AVMUTE flags in the General Control Packet when executing AVMUTE (set/clear) operations.

Note) HDMI 300MHz unit VM-1823 does not support this function. It always works as “Keeping Status” .

<p>(1) Select Configuration using  →  or  INC  DEC, and then press .</p>	
<p>(2) Select HDMI using  or  INC  DEC, and then press .</p>	
<p>(3) Select AVMUTE Mode using  or  INC  DEC.</p> <p>Select the setting using  or  INC  DEC, and then press .</p> <p>Alternatively, select the setting using the number keys ( to ).</p>	<p>For details on the settings, refer to the table below.</p>

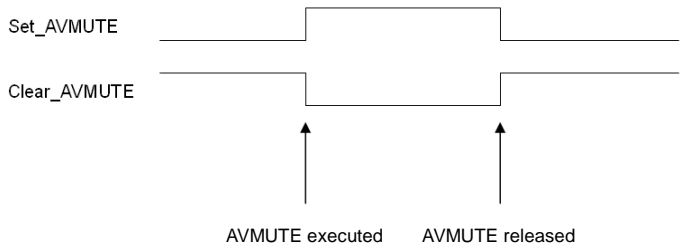
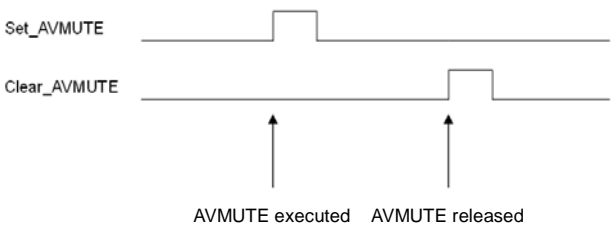
Key	LCD display	Description
0	Keeping Status	<p>The status is always sent with ON set for the Set_AVMUTE flag when executing AVMUTE operations.</p> <p>When AVMUTE is released (when images are output), the status is always sent with ON set for the Clear_AVMUTE flag.</p> 
1	Pulse	<p>The pulses are normally sent with OFF set for both the Set_AVMUTE and Clear_AVMUTE flags.</p> <p>When AVMUTE is executed, OFF is sent after several frames have been sent with ON set for the Set_AVMUTE flag.</p> <p>When AVMUTE is released, OFF is sent after several frames have been sent with ON set for the Clear_AVMUTE flag.</p> <p>* Select these modes when executing HDMI CTS Test-ID 8-16 using the SP-8870 HDMI CTS Tool.</p> 

10

OTHER FUNCTIONS

10.1 Copying and erasing data



















The data stored on the media (internal memory or CF cards) can be copied or erased.







Refrain from ejecting the CF card or turning off the power while data is being copied or erased. Otherwise the CF card and its data may be damaged.

10.1.1 Copying programs





















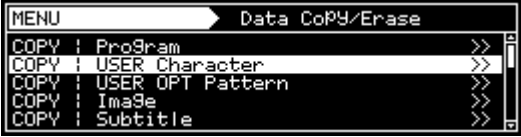



Various methods can be used to copy the program data.

(1)	Select Data Copy/Erase using  →  or   , and then press  .	
(2)	Select Copy: Program using  or   , and then press  .	
(3)	Select the programs using  or   , and then press  . Alternatively: Select the programs using the number keys ( to ), and then press  .	 <p>Type: Select the type of data copying to be used here.</p> <p>Source: Select the copy source number and media here.</p> <p>Destination: Select the copy destination number and media here.</p>

<p><Program categories for Type></p> <p>1-Program: Select this when copying stored programs in their original form.</p> <p>1-SAMPLE TIM&PAT->Program: When combining the timing data and pattern data among the internal sample data to create a program</p> <p>1-TIM (Timing/Output/Audio): When the timing data of the source program is to be combined with the pattern data of the destination program and the existing program is to be overwritten by the program thus created * This setting cannot be used when the program does not exist at the destination end.</p> <p>1-PAT (Pattern/Action): When the pattern data of the source program is to be combined with the timing data of the destination program and the existing program is to be overwritten by the program thus created * This setting cannot be used when the program does not exist at the destination end.</p> <p>Multiple-Program: Select this when copying a multiple number of programs.</p>	<p><Differences in the settings from one type of data to another></p> <p>1-Program Select the source and destination program numbers and the media.</p> <p>1-SAMPLE TIM&PAT->Program Select the timing or pattern data number among the internal sample data to serve as the source, and select the program number and media to serve as the destination.</p> <p>1-TIM(Timing/Output/Audio) Select the program number and media for the timing data to be used as the source, and select the program number and media for the pattern data to be used as the destination.</p> <p>1-PAT(Pattern/Action) Select the program number and media for the pattern data to be used as the source, and select the program number and media for the timing data to be used as the destination.</p> <p>1-Multiple-Program Select the range of the source and destination program numbers and the media.</p>
<p>(4) Select EXECUTE using  or  , and then press  to complete the copying.</p>	





















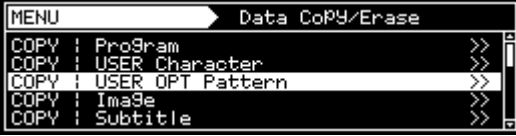

10.1.2 Copying user characters

User character pattern data can be copied.

(1)	<p>Select Data Copy/Erase using  →</p> <p> or  , and then press .</p>	 <pre> MENU Program Edit >>> Group Edit >>> Auto Edit >>> Data Copy/Erase >>> Configuration >>> </pre>
(2)	<p>Select COPY: USER Character using  or</p> <p> , and then press .</p>	 <pre> MENU Data Copy/Erase COPY : Program >>> COPY : USER Character >>> COPY : USER OPT Pattern >>> COPY : Image >>> COPY : Subtitle >>> </pre>
(3)	<p>Select the characters using  or </p> <p>, and then press .</p> <p>Alternatively: Select the characters using the number keys</p> <p> to , and then press .</p>	 <pre> MENU USER Character Copy Source : e0H > CF-Card Destination : e0H > Internal > EXECUTE < </pre> <p>Source: Select the copy source character code (such as e0H) and the media.</p> <p>Destination: Select the copy destination character code (such as e0H) and the media.</p>
(4)	<p>Select EXECUTE using  or  ,</p> <p>and then press  to complete the copying.</p>	 <pre> MENU USER Character Copy Source : e8H > CF-Card Destination : e8H > Internal > EXECUTE < </pre>





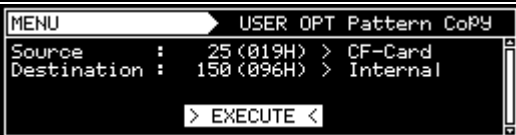



















10.1.3 Copying user optional patterns

User optional pattern data can be copied.

(1)	<p>Select Data Copy/Erase using   or  or  , and then press .</p>	
(2)	<p>Select COPY: USER OPT Pattern using  or  , and then press .</p>	
(3)	<p>Select the patterns using  or  , and then press .</p> <p>Alternatively: Select the patterns using the number keys  to , and then press .</p>	 <p>Source: Select the copy source pattern number and the media.</p> <p>Destination: Select the copy destination pattern number and the media.</p>
(4)	<p>Select EXECUTE using  or  , and then press  to complete the copying.</p>	

























10.1.4 Copying images

Image pattern data can be copied.

(1)	<p>Select Data Copy/Erase using  →</p> <p> or  , and then press .</p>	
(2)	<p>Select COPY: Image using  or </p> <p>, and then press .</p>	
(3)	<p>Select the images using  or </p> <p>, and then press .</p> <p>Alternatively: Select the images using the number keys ( to ) , and then press .</p>	 <p>Source: Select the copy source pattern number and the media.</p> <p>Destination: Select the copy destination pattern number and the media.</p>
(4)	<p>Select EXECUTE using  or  </p> <p>and then press  to complete the copying.</p>	





















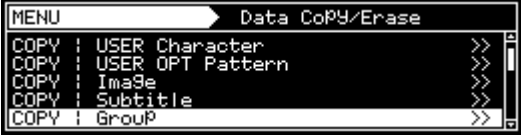



10.1.5 Copying subtitle

Subtitle pattern data can be copied.

(1)	<p>Select Data Copy/Erase using  or  or  , and then press .</p>	
(2)	<p>Select COPY: Subtitle using  or  , and then press .</p>	
(3)	<p>Select the subtitles using  or  , and then press .</p> <p>Alternatively: Select the groups using the number keys ( to ) , and then press .</p>	 <p>Source: Select the copy source pattern number and the media.</p> <p>Destination: Select the copy destination pattern number and the media.</p>
(4)	<p>Select EXECUTE using  or  , and then press  to complete the copying.</p>	

























10.1.6 Copying groups

Group data can be copied.

(1)	<p>Select Data Copy/Erase using  →</p> <p> or  , and then press .</p>	
(2)	<p>Select COPY: Group using  or </p> <p>, and then press .</p>	
(3)	<p>Select the groups using  or  ,</p> <p>and then press .</p> <p>Alternatively:</p> <p>Select the groups using the number keys</p> <p> to , and then press .</p>	 <p>Source: Select the copy source group number and the media.</p> <p>Destination: Select the copy destination group number and the media.</p>
(4)	<p>Select EXECUTE using  or  ,</p> <p>and then press  to complete the copying.</p>	

10.1.7 Copying auto executions



























Auto execution data can be copied.

(1)	<p>Select Data Copy/Erase using  → or  or  , and then press .</p>	
(2)	<p>Select COPY: Auto using  or  , and then press .</p>	
(3)	<p>Select the auto executions using  or  , and then press .</p> <p>Alternatively: Select the auto executions using the number keys ( to ) , and then press .</p>	 <p>Source: Select the copy source media.</p> <p>Destination: Display the copy destination media. (When Source is selected, the media is selected automatically.)</p>
(4)	<p>Select EXECUTE using  or  , and then press  to complete the copying.</p>	

10.1.8 Copying all data

All the data can be copied together.

The time taken to copy the data differs according to how much data is to be copied. It is not possible to cancel copying once it has been initiated.





















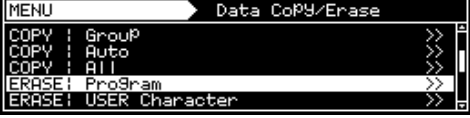



(1)	<p>Select Data Copy/Erase using  →</p> <p> or  , and then press .</p>	
(2)	<p>Select COPY: All using  or  ,</p> <p>and then press .</p>	
(3)	<p>Select the all data using  or </p> <p>, and then press .</p> <p>Alternatively:</p> <p>Select the all data using the number keys</p> <p> </p> <p>( to ), and then press .</p>	 <p>Source: Select the copy source media.</p> <p>Destination: Display the copy destination media. (When Source is selected, the media is selected automatically.)</p>
(4)	<p>Select EXECUTE using  or  ,</p> <p>and then press  to complete the copying.</p>	



Refrain from ejecting the CF card or turning off the power while data is being copied.
Otherwise the CF card and its data may be damaged.

























10.1.9 Erasing programs

Program data can be erased. At the same time, multiple numbers of programs can be erased.

<p>(1) Select Data Copy/Erase using  or  or  , and then press .</p>	
<p>(2) Select ERASE: Program using  or  , and then press .</p>	
<p>(3) Select the program numbers using  or  , and then press .</p> <p>Alternatively: Select the program numbers using the number keys ( to ) , and then press .</p>	 <p>Select the range of the numbers of the programs to be erased and the media.</p>
<p>(4) Select EXECUTE using  or  , and then press  to erase the programs.</p>	

























10.1.10 Erasing user characters

User character pattern data can be erased.

<p>(1) Select Data Copy/Erase using  or  or  , and then press .</p>	
<p>(2) Select ERASE: USER Character using  or  , and then press .</p>	
<p>(3) Select the user character number using  or  , and then press .</p> <p>Alternatively: Select the user character number using the number keys ( to ) , and then press .</p>	 <p>Select the character code (such as e0H) to be erased and the media.</p>
<p>(4) Select EXECUTE using  or  , and then press  to erase the user characters.</p>	





















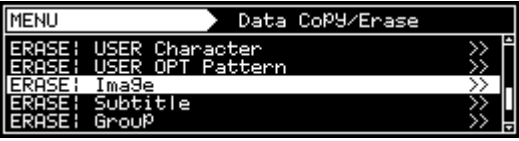



10.1.11 Erasing user optional patterns

User optional pattern data can be erased.

<p>(1) Select Data Copy/Erase using  →  or  , and then press .</p>	
<p>(2) Select ERASE: USER OPT Pattern using  or  , and then press .</p>	
<p>(3) Select the user optional pattern number using  or  , and then press .</p> <p>Alternatively: Select the user optional pattern number using the number keys ( to ) , and then press .</p>	 <p>Select the number of the pattern to be erased and the media.</p>
<p>(4) Select EXECUTE using  or  , and then press  to erase the user optional pattern.</p>	

























10.1.12 Erasing images

Image pattern data can be erased.

<p>(1) Select Data Copy/Erase using  →  or  , and then press .</p>	
<p>(2) Select ERASE: Image using  or  , and then press .</p>	
<p>(3) Select the image number using  or  , and then press .</p> <p>Alternatively: Select the image number using the number keys ( to ) , and then press .</p>	 <p>Select the number of the pattern to be erased and the media.</p>
<p>(4) Select EXECUTE using  or  , and then press .</p>	

























10.1.13 Erasing subtitle

Subtitle pattern data can be erased. At the same time, multiple numbers of programs can be erased.

<p>(1) Select Data Copy/Erase using  or  or  , and then press .</p>	
<p>(2) Select ERASE: Subtitle using  or  , and then press .</p>	
<p>(3) Select the subtitle number using  or  , and then press .</p> <p>Alternatively: Select the image number using the number keys ( to ), and then press .</p>	 <p>Select the range of the numbers of the patterns to be erased and the media.</p>
<p>(4) Select EXECUTE using  or  , and then press .</p>	





















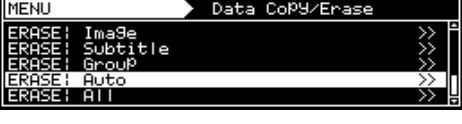



10.1.14 Erasing groups

Group pattern data can be erased. At the same time, multiple numbers of programs can be erased.

<p>(1) Select Data Copy/Erase using  or  or  , and then press .</p>	
<p>(2) Select ERASE: Group using  or  , and then press .</p>	
<p>(3) Select the group number using  or  , and then press .</p> <p>Alternatively: Select the group number using the number keys ( to ), and then press .</p>	 <p>Select the range of the numbers of the groups to be erased and the media.</p>
<p>(4) Select EXECUTE using  or  , and then press  to erase the group.</p>	

























10.1.15 Erasing automatic executions

Automatic execution data can be erased.

<p>(1) Select Data Copy/Erase using  →  or  , and then press .</p>	
<p>(2) Select ERASE: Auto using  or  , and then press .</p>	
<p>(3) Select the media using  or  , and then press .</p> <p>Alternatively: Select the media with the automatic executions using the number keys ( to ), and then press .</p>	 <p>Select the media whose data is to be erased.</p>
<p>(4) Select EXECUTE using  or  , and then press  to erase the automatic executions.</p>	

















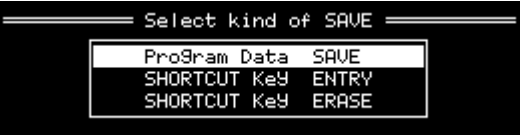













10.1.16 Erasing all data

All the data can be erased together.

<p>(1) Select Data Copy/Erase using  →  or  , and then press .</p>	
<p>(2) Select ERASE: All using  or  , and then press .</p>	
<p>(3) Select the media with the data using  or  , and then press .</p> <p>Alternatively: Select the media with the data using the number keys ( to ), and then press .</p>	 <p>Select the media whose data is to be erased.</p>
<p>(4) Select EXECUTE using  or  , and then press  to erase all the data.</p>	

10.2 Short-cut keys

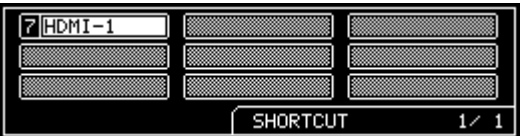











It is possible to set up to any of 90 frequently used screens so that they can be called by pressing the short-cut keys.

<p>(1) Display the screen which is to be registered as a short-cut, and then press  . In the example given here, the HDMI setting screen is registered.</p>	
<p>(2) Select ShortCUT Key ENTRY using  or   , and then press  . To erase the selection, select SHORTCUT Key ERASE, and then press  .</p>	
<p>(3) Select the position where the screen is to be registered using  or   , and then press  . In this example, the screen is saved in 7 in the first page. * The selected positions 1 to 9 correspond to  to  .</p>	 <p>current page/total pages </p>
<p>(4) Set the name of the screen registered. If the name already displayed is acceptable, select OK, and then press  . To change the name: Change the name using     , and then press  . The new name in this example is HDMI-1. When the setting is saved, "Save Completed" is displayed and the registered screen is returned to the display in step (1) above.</p>	 
<p>(5) <Calling a menu screen with SHORTCUT> When  is pressed, the SHORTCUT screen is displayed. HDMI-1, which is the registered screen, is now registered in shortcut 7 in the first page. Use  , or alternatively use  or   (for page selection) and then press  to display the HDMI setting screen,</p>	 <p>current page/total registered pages </p>

- * The shortcut key function may be disabled on some display screens. Use ESC to return to the previous screen, and press the keys again.

10.3 Information

The main unit's version, serial number and other information can be displayed.













(1)	<p>Select Maintenance using   or  or  , and then press .</p>	
(2)	<p>Select Information, and then press .</p>	
(3)	<p>Scroll the display up or down using  or  .</p>	

<Table of items displays>

Example of display	Description
TYPE: VG-870A/B (0000) SERIAL: 1234567 (0000000) MAC: 00 02 de 00 00 00 LICENSE: 0.25dot Scroll Macrovision H/W Ver.: 00 S00-00 FPGA M01.00/S01.00/R01.00 F/W Ver.: 01.00 (0000)	Product name Serial number MAC address Usable option functions Hardware version Firmware version
- UNIT ----- SLOT0) TYPE: VM-1811 SERIAL: 0000000 H/W Ver.: 01(V) S00-00 FPGA01.00 F/W Ver.: 01.00 TX1 Ver.: CG V 1.1.1 USER ADJUSTMENT VALUE: R/G/B = +0/+0/+0	(Listed below is the output unit information.) Unit type Serial number Hardware version Firmware version DisplayPort Transmitter Ver. (DP unit only) User adjustment values (dependent on type of unit) * The 'SLOT' number is given in the sequence (0 → 1 → 2) counting from the lowest slot on the rear panel of the main unit. The 'INT' number is given for the internal moving image module
- DISK SPACE ----- FSystem Used Available Mounted rom0a 13360 (12%) 96998 c:	(Listed below is the amount of the device's memory which has been used.) Mounted c: Internal memory d: CF card

10.4.2 Initializing the short-cut data

This operation restores the short-cut data to the factory settings.

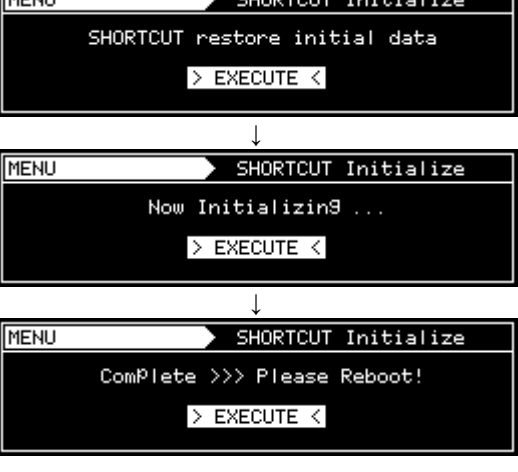











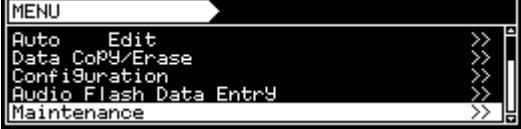

(1)	<p>Select Maintenance using  or  or  , and then press .</p>	 <pre> MENU Auto Edit >> Data Copy/Erase >> Configuration >> Audio Flash Data Entry >> Maintenance >> </pre>
(2)	<p>Select INITIALIZE: SHORTCUT using  or  , and then press .</p>	 <pre> MENU Maintenance Information >> INITIALIZE: Configuration >> INITIALIZE: SHORTCUT >> FORMAT CF-Card >> FORMAT CF-Card(Moving Image) >> </pre>
(3)	<p>Press  to execute initialization.</p> <p>⋮</p> <p>⋮</p> <p>⋮</p> <p>⋮</p> <p>⋮</p> <p>⋮</p> <p>⋮</p> <p>⋮</p> <p>Initialization is completed.</p>	 <pre> MENU SHORTCUT Initialize SHORTCUT restore initial data > EXECUTE < ↓ MENU SHORTCUT Initialize Now Initializing ... > EXECUTE < ↓ MENU SHORTCUT Initialize Complete >>> Please Reboot! > EXECUTE < </pre>
(4)	<p>Turn off the generator's power, and restart the generator.</p>	

10.5 Formatting

10.5.1 Formatting the CF card

Described below is the procedure used to format the CF card.

















* For further details on the CF card used for the moving image module, refer to “10.5.2 Formatting CF cards for exclusive use of moving images.”

<p>(1) Select Maintenance using  or  or  , and then press .</p>	
<p>(2) Select FORMAT : CF-Card using  or  , and then press .</p>	
<p>(3) Press  to perform formatting.</p>	
<p>(4) A confirmation message is displayed. To continue the formatting, select ; to cancel the formatting, select .</p> <p style="text-align: center;">: : :</p> <p>Formatting is completed.</p>	 <p style="text-align: center;">↓ Now Formatting ... ↓ Card Format Completed ↓ Display in step (3)</p>

10.5.2 Formatting CF cards for exclusive use of moving images

Described below is the procedure used to format the CF card used exclusively for moving images.

* The CF card for exclusive use of moving images is used with the moving image module, and its ejection slot is located on the side panel of the VG main unit. (For further details, refer to “1.4.7 VG-870B/871B/873/874 side panel”) Bear in mind that the file system for these cards is different from the system for the CF cards used by the slot on the front panel of the VG main unit.

<p>(1) Select Maintenance using  or  or  , and then press .</p>	
<p>(2) Select FORMAT : CF-Card (Moving Image) using  or  , and then press .</p>	
<p>(3) Press  to perform formatting.</p>	
<p>(4) A confirmation message is displayed.</p> <p>To continue the formatting, select ; to cancel the formatting, select .</p> <p style="text-align: center;">:</p> <p style="text-align: center;">:</p> <p style="text-align: center;">:</p> <p>Formatting is completed.</p>	 <p style="text-align: center;">↓</p> <p style="text-align: center;">Now Formatting ...</p> <p style="text-align: center;">↓</p> <p style="text-align: center;">Card Format Completed</p> <p style="text-align: center;">↓</p> <p style="text-align: center;">Display in step (3)</p>

10.5.3 Internal memory formatting and data installation

The procedure for formatting the internal memory is described below.



Formatting the internal memory will delete the data required for the generator's operation so the steps for data installation and firmware version updating must be taken after the memory has been formatted.

<Procedure>

1. Have the required data ready.
2. Format the internal memory. Refer to **<Formatting procedure>**.
3. Turn the power on from the off status.
4. Install the data. Refer to **<Data installation procedure>**.
5. Turn off the power.
6. Update the firmware version. Refer to **<Firmware version updating procedure>**.
7. Power off the power, and then turn it back on.

<Required data>

















- The required data is the data in the **InitialData** folder on the SP-8870 software installation disk which is provided with the VG generator so copy it onto a CF card.
- If the firmware version has been updated at some point after the generator was purchased, the data of the updated version will be required.

Further action must be taken in either of the following events.

Make inquiries with your dealer or an ASTRODESIGN sales representative.

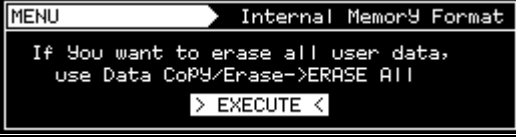
- When APDC patterns (optional) are being used
APDC patterns are not included in the data provided with the SP-8870 software.
 - When the VG generator is not a standard model
The data provided with the SP-8870 software is for a standard model.
-

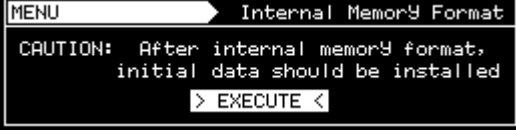
<Formatting procedure>

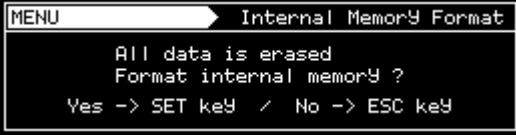



















<p>(1) Select Maintenance using  or  or  , and then press .</p>	
<p>(2) Select FORMAT: Internal Memory using  or  , and then press .</p>	
<p>(3) The message appears as right picture. Press , and go to step (4).</p>	
<p>(4) Initiate formatting by pressing .</p>	
<p>(5) A confirmation message appears. To continue with the formatting, select ; to cancel the formatting, select . : : Formatting is now completed.</p>	 <p style="text-align: center;">↓ Now Formatting ... ↓ Complete >>> Please Reboot!</p>
<p>(6) Turn off the power and then turn it back on. Now install the data.</p>	

10.6 Adjustments

10.6.1 Adjusting the RGB video levels of the PC analog unit

The RGB video levels of the PC analog unit will be adjusted in this section.

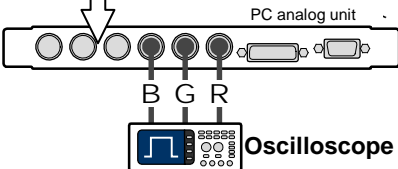

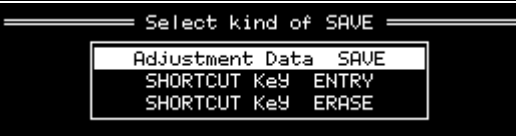

















After adjusting the levels, save the data.

<p>(1)</p> <ul style="list-style-type: none"> • Display the raster 'white' pattern (No.1121) using any timing data. • Check that the digital levels are the maximum values. (Refer to "4.1.8 Setting the digital level.") • Set the analog levels to the desired values. (Refer to "4.7.2 Setting the analog output connectors") 	
<p>(2)</p> <p>Select Maintenance using  →  or  or , and then press .</p>	
<p>(3)</p> <p>Select ADJUST: PC-RGB using  or , and then press .</p>	
<p>(4)</p> <p><Where there is a multiple number of PC analog units></p> <p>Use  to select "SLOT."</p> <p>Then use   to select the number of the slot which contains the unit whose levels are to be adjusted.</p>	 <p style="text-align: center;">↑ Display representing generator's rear panel</p>
<p>(5)</p> <p>Select "R," "G" and "B" using .</p> <p>While monitoring the actual level on an oscilloscope or other measuring device, adjust to the value set in step (1) using  (to increase the level) or  (to reduce the level).</p> <p>* Perform the step for "R," "G" and "B."</p>	 <div style="text-align: center;">  <p>PC analog unit</p> <p>B G R</p> <p>Oscilloscope</p> </div>
<p>(6)</p> <p>Press .</p> <p>Then select "Adjustment Data SAVE" followed by .</p> <p>After 'Save Completed' has appeared, operation returns to the screen in step (5).</p>	

10.6.2 Adjusting the YPbPr video levels of the TV encoder unit

The YPbPr video levels of the TV encoder unit will be adjusted in this section.

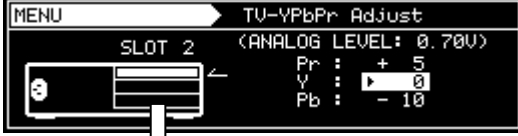
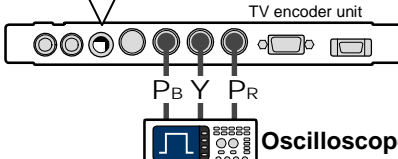

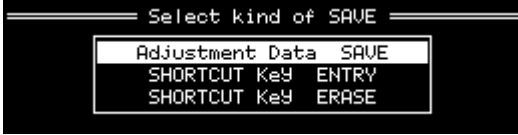



















After adjusting the levels, save the data.

(1)	<ul style="list-style-type: none"> • Display the raster 'white' pattern (No.1121) using any timing data. • Check that the digital levels are the maximum values. (Refer to "4.1.8 Setting the digital level.") • Set the analog levels to the desired values. (Refer to "4.7.2 Setting the analog output connectors") 	
(2)	Select Maintenance using  or  or   , and then press  .	
(3)	Select ADJUST TV-YPbPr using  or   , and then press  .	
(4)	<When there is a multiple number of TV encoder units> Use  to select "SLOT." Then use   to select the number of the slot which contains the unit whose levels are to be adjusted.	 Display representing generator's rear panel
(5)	Select " Pr ," " Y " and " Pb " using  . While monitoring the actual level on an oscilloscope or other measuring device, adjust to the value set in step (1) using  (to increase the level) or  (to reduce the level). * Perform the step for "Pr," "Y" and "Pb."	 
(6)	Press  . Then select " Adjustment Data SAVE " followed by  . After 'Save Completed' has appeared, operation returns to the screen in step (5).	

10.6.3 Adjusting the COMPOSITE/SCART video levels of the TV encoder unit

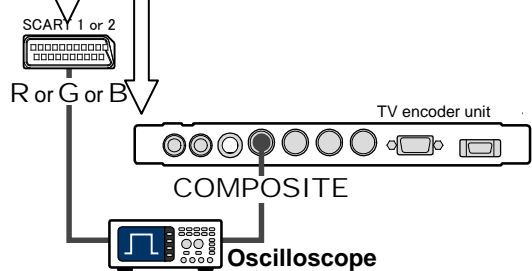
The COMPOSITE/SCART video levels of the TV encoder unit will be adjusted in this section.

After adjusting the levels, save the data.

<p>(1)</p> <ul style="list-style-type: none"> • Display the raster 'white' pattern (No.1121) using any timing data (NTSC, PAL, SECAM, etc.). • Check that the digital levels are the maximum values. (Refer to "4.1.8 Setting the digital level.") 	
<p>(2)</p> <p>Select Maintenance using  or  or  , and then press .</p>	
<p>(3)</p> <p>Select ADJUST: TV-COMPOSITE/SCART using  or  , and then press .</p>	
<p>(4)</p> <p><When there is a multiple number of TV encoder units></p> <p>Use  to select "SLOT."</p> <p>Then use   to select the number of the slot which contains the unit whose levels are to be adjusted.</p> <p>* Only SLOT '2' is used for SCART. * For the standard timing data values, refer to "11.3.5 Tables of standard signals."</p>	 <p style="text-align: center;">↑ Display representing generator's rear panel</p>
<p>(5)</p> <p>Select "COMPOSITE" or "RGB (SCART)" using .</p> <p>Then, while monitoring the actual level on an oscilloscope or other measuring device, adjust the level using  (to increase the level) or  (to reduce the level).</p>	 <p style="text-align: center;">↓</p> 
<p>(6)</p> <p>Press .</p> <p>Then select "Adjustment Data SAVE" followed by .</p> <p>After 'Save Completed' has appeared, operation returns to the screen in step (5).</p>	

11

SPECIFICATIONS

11.1 Main specifications

11.1.1 Common specifications

Dot clock frequencies	VG-870B/873	Analog	8 - 10 bit: 0.100 - 340.000 MHz 11 - 12 bit: 0.100 - 330.000 MHz 13 - 14 bit: 0.100 - 280.000 MHz 15 - 16 bit: 0.100 - 240.000 MHz
		Digital	8 - 10 bit: 0.100 - 340.000 MHz 11 - 12 bit: 0.100 - 330.000 MHz 13 - 14 bit: 0.100 - 280.000 MHz 15 - 16 bit: 0.100 - 240.000 MHz
			VM-1824 (with Quad output) 8 - 10 bit: 296.000 - 660.000 MHz 11 - 12 bit: 296.000 - 600.000 MHz
	VG-871B/874	Analog	8 to 10 bit: 0.100 - 250.000 MHz 11 - 12 bit: 0.100 - 250.000 MHz 13 - 14 bit: 0.100 - 250.000 MHz 15 - 16 bit: 0.100 - 240.000 MHz
		Digital	8 - 10 bit: 0.100 - 340.000 MHz 11 - 12 bit: 0.100 - 330.000 MHz 13 - 14 bit: 0.100 - 280.000 MHz 15 - 16 bit: 0.100 - 240.000 MHz
			VM-1824 (with Quad output) 8 - 10 bit: 296.000 - 660.000 MHz 11 - 12 bit: 296.000 - 600.000 MHz
Horizontal frequency		Max. 300 kHz, 8192 dots	
Number of vertical scanning lines		Max. 8192 lines *1	
Video memory		4096 dots x 4096 dots	
Serration pulse (Serration)		OFF, 0.5H, 1H or EXOR selectable	
Scanning		Progressive (non-interlaced), interlaced, segmented frame, interlace (sync)	

*1 The maximum number of vertical scanning lines is 2046 for the DisplayPort output.

11.1.2 HDMI unit

HDMI1 HDMI2	Connectors		HDMI × 2			
	DotCLK		8-bit output	VM-1817, 1822	25 to 165 MHz (TMDS CLK:165 MHz)	
				VM-1823	25 to 300MHz (TMDS CLK: 300MHz)	
			10-bit output	VM-1817, 1822	25 to 165 MHz (TMDS CLK:206.25 MHz)	
				VM-1823	25 to 240MHz (TMDS CLK: 300MHz)	
			12-bit output	VM-1817, 1822	25 to 150 MHz (TMDS CLK:225 MHz)	
				VM-1823	25 to 200MHz (TMDS CLK: 300MHz)	
			16-bit output	VM-1817, 1822	Not supported	
	VM-1823	25 to 150MHz (TMDS CLK: 300MHz)				
	Number of colors generated			8, 10 or 12 bits each for R, G and B (RGB, YCbCr444 and YCbCr422 formats supported)		
	Audio output	HDMI	L-PCM	Sampling frequency: 32, 44.1, 48, 88.2, 96, 176.4, 192 kHz Output frequency: 100 to one-half of sampling frequency (Hz) No. of bits: 16, 20 or 24 bits		
			Options	Next-generation audio technologies supported DSD, Dolby Digital Plus, Dolby True HD, DTS HD (High Resolution Audio), DTS HD (Master Audio), etc.		
		COAX *2	Sampling frequency: 32, 44.1, 48, 88.2, 96, 176.4, 192 kHz			
	Audio input	RCA *1	Input format	Analog L/R		
		COAXIAL Optical *1	Input format	S/PDIF format		
			sampling frequency	Fs = 32 to 192 kHz		
		I2S IN (option)	MCLK frequency *3	Fs = 48 kHz system	24.576 MHz	
				Fs = 44.1 kHz system	22.5792 MHz	
			Input format	Next-generation audio technologies supported (I2S format)		
	<td>sampling frequency</td> <td colspan="3">Fs = 32 to 768 kHz</td>	sampling frequency	Fs = 32 to 768 kHz			
HDMI ARC *2	sampling frequency	Fs = 32 to 192 kHz				
Copy protection			HDCP Ver1.2			
Additional functions			E-EDID Ver1.3 (DDC2B), xvYCC, CEC			

*1: This function is supported only by the VM-1817.

*2: This function is supported only by VM-1822, 1823.

*3: The frequencies for 48 kHz systems are 32 kHz, 48 kHz, 96 kHz, 192 kHz and 768 kHz; the frequency for 44.1 kHz systems are 44.1 kHz, 88.2 kHz and 176.4 kHz.

11.1.3 TV encoder unit (VM-1812)

VGA	DotCLK	5 to 165 MHz
	No. of colors generated	8 bits each for R, G, B
	Connector	Dsub x 1
D5	DotCLK	HDTV (1920 x 1080i/1080p/720p), SDTV (720 x 480p/480i)
	No. of colors generated	8 bits each for R, G, B
	Connector	D connector x 1 (D5 output supported)
YPbPr	DotCLK	HDTV (1920 x 1080i/1080p/720p), SDTV (720 x 480p/480i)
	No. of colors generated	8 bits each for R, G, B
	Connector	BNC x 3
COMPOSITE Y/C	DotCLK	NTSC-M/J/443, PAL (B/D/G/H/I)/M/N/Nc/60, SECAM See below note
	No. of colors generated	8 bits each for R, G, B
	Connector	COMPOSITE x 1, Y/C (S-VIDEO) x 1
	Additional functions	Teletext, Closed Caption, V-Chip, Macrovision (options)
SCART1 SCART2	DotCLK	NTSC-M/J/443, PAL (B/D/G/H/I)/M/N/Nc/60, SECAM See below note
	No. of colors generated	8 bits each for R, G, B
	Connector	SCART x 2
	Additional functions	Teletext, Closed Caption, V-Chip, Macrovision (options)
AUDIO L/R	Audio output	RCA x 2
	Output frequency	20 to 20 KHz
	Output level	0 to 2000 mV

Note: VM-1812-B does not support PAL-N, PAL-60, SECAM. Option Pattern #77 (SMPTE color bar CVBS) is not supported.

11.1.4 PC analog unit (VM-1811)

VGA RGB/HS/VS DVI-I (analog unit)	DotCLK	5 to 300 MHz
	No. of colors generated	10 bits each for R, G, B
	Video level	300 to 1200 mV (with VideoOnSync ON) 50 to 1200 mV (with VideoOnSync OFF)
	Sync level	HS/VS: TTL VideoOnSync: 0 to 600 mV (2-level), 0 to \pm 600 mV (tri-level)
	Connector	BNC x 3 (RGB), BNC x 2 (HS/VS), Dsub x 1
CS	Sync level	CS: 300 mV (2-level), 600 mV (tri-level)
	Connector	BNC x 1
DVI-I (digital unit)	DotCLK	25 to 165 MHz
	No. of colors generated	8 bits each for R, G, B
	Copy protection	HDCP Ver1.0
	Additional functions	E-EDID Ver1.3 (DCC2B)
	Connector	DVI-I x 1 (HDCP supported)

11.1.5 DVI unit (VM-1814)

DVI1	DotCLK	Single Link	25 to 165 MHz (to 8 bits)
			25 to 165 MHz (to 16 bits)
		Dual Link	50 to 330 MHz (to 8 bits)
	No. of colors generated		16 bits each for R, G, B
	Copy protection		None
	Additional functions		E-EDID Ver1.3 (DDC2B)
Connector		DVI-D × 1 (Dual Link supported)	
DVI2	DotCLK		25 to 165 MHz (to 8 bits)
	No. of colors generated		8 bits each for R, G, B
	Copy protection		HDCP Ver1.0
	Additional functions		E-EDID Ver1.3 (DDC2B)
	Connector		DVI-D × 1 (HDCP supported)

11.1.6 LVDS unit (VM-1815)

LVDS1 LVDS2 LVDS3 LVDS4	DotCLK	Single Link	20 to 135 MHz (to 16 bits)
		Dual Link	40 to 270 MHz (to 14 bits)
			40 to 240 MHz (to 16 bits)
		Quad Link	80 to 340 MHz (to 10 bits)
	No. of colors generated		16 bits each for R, G, B
Connector		LVDS × 4	

11.1.7 PARALLEL unit (VM-1816)

PARALLEL1 PARALLEL2	DotCLK	Single Link	0.1 to 100 MHz (to 16 bits)		
		Dual Link	0.2 to 200 MHz (to 8 bits)		
	No. of colors generated		16 bits each for R, G, B		
	Output voltage level		Output signal voltage level (SIGNAL) and output power supply voltage level (POWER) settings		
			Positions of the switches	Voltage level [V]	
			1	1.8	
			2	2.5	
		3	3.3		
		4	5		
Connector		PARALLEL × 2			

11.1.8 DP unit (VM-1820 / 1820A)

DP1 DP2	Version supported		VESA DisplayPort Standard Ver.1.1a	
	Connectors		DisplayPort x 2	
	DotCLK	Single Mode	16 to 270 MHz However, according to each setting. (*1)	
		Dual Mode	32 to 340 MHz	
		Split Mode	However, according to each setting. (*1)	
	Audio output	L-PCM	Sampling frequency: 32/44.1/48/88.2/96 kHz Output frequency: 100 to "half of the sampling frequency" Hz Number of bit: 16/20/24 bit	
	Number of colors		8 or 10 bits each for R, G and B (RGB and YCbCr444 formats)	
	DisplayPort I/F	Link Rate	1.62 GHz/2.7 GHz	
		Number of Lane	1/2/4 lanes	
	Audio input	Optical	Input format	S/PDIF format
Sampling frequency			Fs=32 to 96 kHz	
Auxiliary channel support		DPCD, EDID, DDC/CI, HDCP		

*1 The maximum dot clock for DisplayPort is as follows according to the link rate, number of lanes, drawing mode, bit length, and color format settings.

Item			Maximum dot clock [MHz]					
Link Rate	Lane count	Drawing mode	16 bit	18 bit	20bit	24 bit		30 bit
			YC422 8 bit	RGB/ YC444 6 bit	YC422 10 bit	RGB/ YC444 8 bit	YC422 12 bit	RGB/ YC444 10 bit
2.7 Gbps	1	Single	135	120	108	90	90	72
		Dual/Split	270	240	216	180	180	144
	2	Single	270	240	216	180	180	144
		Dual/Split	340	340	340	340	330	288
	4	Single	270	270	270	270	270	270
		Dual/Split	340	340	340	340	330	340
1.62 Gbps	1	Single	81	72	64.8	54	54	43.2
		Dual/Split	162	144	129.6	108	108	86.4
	2	Single	162	144	129.6	108	108	86.4
		Dual/Split	324	288	259.2	216	216	172.8
	4	Single	324	288	259.2	216	216	172.8
		Dual/Split	340	340	340	340	330	340

*2 The DisplayPort output can be output at a horizontal timing of only 2-dot units in Single mode, or 4-dot units in Dual or Split mode.

*3 When the YCbCr4:2:2 format has been selected, up to 12 bits can be set as the bit length. However, it is not possible to display the gray scale which accords with the bit length (gray scale) which has been set (64-step gray scale with an 8-bit output). Use this parameter to check the Main Stream Attribute parameters rather than using it to assess the image quality.

*4 The maximum number of vertical scanning lines is 2046 for the DisplayPort output.

11.1.9 DP/eDP Unit (VM-1826)

DP1 DP2	Standard		VESA DisplayPort Standard Ver.1.1a	
	Connector		DisplayPortx2	
	DotCLK	Single Mode	16 - 330MHz Depends on the setting. (Refer to *1)	
		Dual Mode	32 - 340MHz Depends on the setting. (Refer to *1)	
		Split Mode	340 - 660MHz Depends on the setting. (Refer to *1)	
	Output color numbers		8/10bit (RGB/ YCbCr444 format) 12bit (YCbCr422)	
	Audio Output	L-PCM	Sampling : 32k/ 44.1k/ 48k/ 88.2k/ 96k/176.4/192KHz Output frequency: from 100 (1/2 of sampling frequency)Hz Bit number : 16/20/24bit	
	DisplayPort I/F	Link Rate	1.62Gbps / 2.7Gbps	
		Lane count	1 / 2 / 4Lanes	
AUX CH support		DPCD, EDID, DDC/CI, HDCP		
eDP	Control signal Power out	Connector	DX10G1M-50SE (maker : Hirose Electric)	
		Control signal	8 lines	
		Power out	4 lines Internal power (5V/3.3V)/ External power input 1/2	
		Power control signal	RS-232C	
	External power input	Connector	DF1BZ-12DP-2.5DS (maker : Hirose Electric)	
Audio	Audio input	Coaxial	Input format	S/PDIF format
			Sampling frequency	Fs = 32 to 96kHz

*1 The maximum dot clock of DisplayPort changes by the setting of Link Rate, Lane number, drawing mode, Bit length and color format.

Item			Maximum Dot CLK [MHz]					
Link Rate	Lane count	Drawing mode	16bit	18bit	20bit	24bit	30bit	16bit
			YC422 8bit	RGB /YC444 6bit	YC422 10bit	RGB /YC444 8bit	YC422 12bit	YC422 8bit
2.7 Gbps	1	Single	135	120	108	90	90	135
		Dual	270	240	216	180	180	270
		Split	540	480	432	360	360	540
		Split2	1080	960	864	720	720	1080
	2	Single	270	240	216	180	180	270
		Dual	340	340	340	340	330	340
		Split	660	660	660	660	660	660
		Split2	1320	1320	1320	1320	1320	1320
	4	Single	330	330	330	330	330	330
		Dual	340	340	340	340	330	340
		Split	660	660	660	660	660	660
		Split2	1320	1320	1320	1320	1320	1320
1.62 Gbps	1	Single	81	72	64.8	54	54	81
		Dual	162	144	129.6	108	108	162
		Split	324	288	259.2	216	216	324
		Split2	648	576	518.4	432	432	648
	2	Single	162	144	129.6	108	108	162
		Dual	324	288	259.2	216	216	324
		Split	648	576	518.4	432	432	648
		Split2	1296	1152	1036.8	864	864	1296
	4	Single	324	288	259.2	216	216	324
		Dual	340	340	340	340	330	340
		Split	660	660	660	660	660	660
		Split2	1320	1320	1320	1320	1320	1320

11.1.10 4K2K (iTMSD, iTMSD Quad) unit (VM-1824, VM-1824-A)

DVI1 DVI2 (DVI3) (DVI4)	DotCLK	DVI MODE	8bit	25 to 165MHz (SingleLink) 50 to 330MHz (DualLink)
		iTMSD MODE	8-10bit	25 to 165MHz (SingleLink) 50 to 330MHz (DualLink)
			12bit	25 to 150MHz (SingleLink) 50 to 300MHz (DualLink)
		MULTI CH MODE	10-16bit	25 to 165MHz (DualLink) 50 to 330MHz (QuadLink)
		4Kx2K MODE	8-12bit	296 to 660MHz (QuadLink) 592 to 1320MHz (OctalLink) *1
	Number of colors generated			16 bits each for R, G, B
Copy protection			HDCP Ver.1.0 *2	
Additional function			E-EDID Ver1.3(DDC2B) *3	

*1 Octal Link takes effect only when two output boards are used. It will not work when only one board is used.

*2 The VM-1824 (DVI Dual Link is equipped) does not support it.

*3 This has been supported starting with firmware version Ver.3.30.

- Horizontal timing restrictions

Minimum horizontal blanking period	168 dots (384 dots in the 2-board mode)
Minimum horizontal display width	476 dots (996 dots in the 2-board mode)

- Setting increments for VM-1824 (VM-1824-A) screen splitting

	Quad		Octal	
	H	V	H	V
Mode 0	2dot	2line	4dot	2line
Mode 1	4dot	1line	8dot	1line
Mode 2	2dot	2line	4dot	2line
Mode 3	4dot	1line	8dot	1line

	Quad (x4Mode)	
	H	V
Mode 0	4dot(8dot)✕	1line
Mode 1	4dot(8dot)✕	1line
Mode 2	4dot(8dot)✕	1line
Mode 3	4dot(8dot)✕	1line
Mode 4	4dot(8dot)✕	1line

* When the screen is split-output into 8 using IA-1540, the setting increment is 8-dot.

11.1.11 V-by-One HS unit

V-by-One HS1 V-by-One HS2	DotCLK	Normal MODE	8-10 bit	20 to 75 MHz (1 Lane)
				40 to 150 MHz (2 Lane)
				80 to 300 MHz (4 Lane)
		4k2k (60Hz) MODE x4 MODE	8-10 bit	160 to 600 MHz (8 Lane)
				320 to 1200MHz (16 Lane)
		Video format		
	Color resolution			With 8 bits: 256 × RGB (YC) colors With 10 bits: 1024 × RGB (YC) colors
	Level setting			With 8 bits: 256 steps With 10 bits: 1024 steps

● Setting increments for VM-1825 screen splitting

	8Lane		16Lane	
	H	V	H	V
Mode 0	2dot	2line	4dot	2line
Mode 1	4dot	1line	8dot	1line
Mode 2	2dot	2line	4dot	2line
Mode 3	4dot	1line	8dot	1line

	8Lane (x4Mode)	
	H	V
Mode 0	4dot	1line
Mode 1	4dot	1line
Mode 2	4dot	1line
Mode 3	4dot	1line
Mode 4	4dot	1line

11.1.12 SDI unit (VM-1821)

The SDI outputs take effect only with the timings are rated below.

SDI1 SDI2 SDI3 SDI4	Formats supported	SD-SDI	NTSC PAL	YCbCr:422 10bit	SMPTE-259M	
		HD-SDI	1920x1080p 30/29.97/25/24/23.98	YCbCr:422 10bit	SMPTE-274M	
			1920x1080psf 30/29.97/25/24/23.98			
			1920x1080i 60/59.94/50	YCbCr:422 10bit	SMPTE-296M	
			1280x720p 60/59.94/50 30/29.97/25/24/23.98			
		3G-SDI (LEVEL A/B)	1920x1080p 60/59.94/50	YCbCr:422 10bit	SMPTE-425M	
			1920x1080p 30/29.97/25/24/23.98	YCbCr:422 12bit		
			1920x1080psf 30/29.97/25/24/23.98	YCbCr:444 10bit		
			1920x1080i 60/59.94/50	YCbCr:444 12bit		
		Dual-Link	1280x720p 60/59.94/50 30/29.97/25	RGB 10bit RGB 12bit		
			1920x1080p 60/59.94/50	YCbCr:422 10bit	SMPTE-372M	
				1920x1080p 30/29.97/25/24/23.98		YCbCr:422 12bit
				1920x1080psf 30/29.97/25/24/23.98		YCbCr:444 10bit
		1920x1080i 60/59.94/50	YCbCr:444 12bit			
			RGB 10bit RGB 12bit			
Audio output	L-PCM	Number of channels: 8 Sampling frequency: 48 kHz Output frequency: 100 to (one-half of sampling frequency) Hz No. of bits: 16, 20 or 24 bits				

*1 The SDI outputs are as shown below.

- (1) SD/HD/3G-SDI
The signals are distributed from OUT1, OUT2, OUT3 and OUT4, and output.
- (2) Dual-Link
The signals are output from OUT1 and OUT3 as one pair and OUT2 and OUT4 as another pair (to form two distributed outputs).

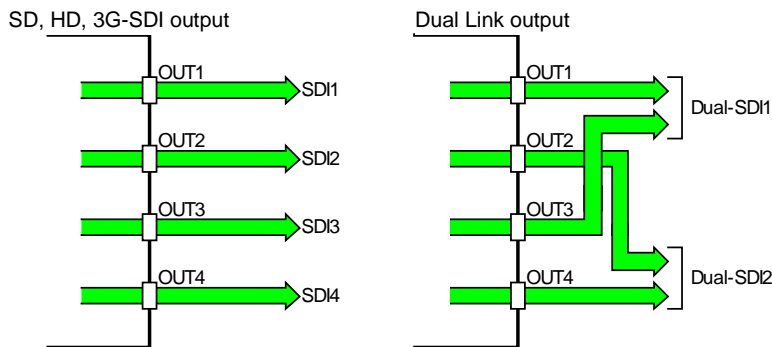

11.1.13 Moving image module

Image memory	4GB (SO-DIMM 2GB × 2)	
Video format	RGB (4:4:4)/10 bit	
	YPbPr (4:2:2)/10 bit	
Playback time	Full HD (1920 × 1080)/60p	RGB (4:4:4) approx. 8 sec.
		YPbPr (4:2:2) approx. 12 sec.

11.1.14 External control

Dedicated remote controllers	RB-1870, RB-1871
Serial control	RS-232C
LAN	10/100BASE-T

11.1.15 General specifications

Supply voltage	AC100 to 240 V
Power line frequency	50/60 Hz
Power consumption	80 VA MAX
Dimensions	430 (W) × 88 (H) × 370 (D) mm (excluding protrusions)
Weight	Approx. 6.85 kg (when 3 output units have been installed)
Operating temperature range	5 to 40°C
Operating humidity range	30 to 80%RH (no condensation)

11.2 Connector specifications

11.2.1 RS232C-Connector

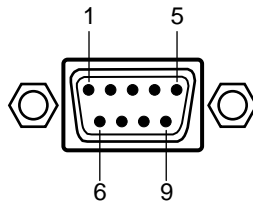

Pin no.	I/O	Signal
1	-	NC
2	O	TXD (transmitted data)
3	I	RXD (received data)
4	-	Shorted with pin 6
5	-	FG (frame ground)
6	-	Shorted with pin 4
7	I	CTS (clear to send)
8	O	RTS (request to send)
9	-	NC

11.2.2 Trigger-Connector



Pin no.	I/O	Signal
1	O	TRIG_OUT3
2	O	TRIG_OUT2
3	O	TRIG_OUT1
4	-	GND
5	O	TRIG_OUT0
6	-	GND
7	I	RESEARVE
8	-	GND

* The output of trigger is an open-collector output. It is pulled up by 10 k Ω , 5 V internally.

11.3 Internal data

11.3.1 Program data

Program No.	Horizontal frequency [KHz]	Vertical frequency [Hz]	Dot clock frequency [MHz]	No. of display dots (H × V)	Int / Prog	Sync polarity		SyncType	Color difference	Timing data name	Pattern data	Pattern data name
						H	V					
1001	31.47	59.94	25.175	640 × 480	Prog	N	N	ANALOG	RGB	EIA640 × 480p@59.94	100%/100% color bars, horizontal direction	Color Bar 100/100-H
1002	31.50	60.00	25.200	640 × 480	Prog	N	N	ANALOG	RGB	EIA640 × 480p@60	100%/75% color bars, horizontal direction	Color Bar 100/75-H
1003	31.47	59.94	27.000	720 × 480	Prog	N	N	ANALOG	YPbPr	EIA720 × 480p@59.94	75%/75% color bars, horizontal direction	Color Bar 75/75-H
1004	31.50	60.00	27.027	720 × 480	Prog	N	N	ANALOG	YPbPr	EIA720 × 480p@60	SMPTE color bars	Color Bar SMPTE
1005	31.47	59.94	27.000	720 × 480	Prog	N	N	ANALOG	YPbPr	EIA720 × 480pW@59.94	RGBW color bars, vertical direction	Color Bar RGBW-V
1006	31.50	60.00	27.027	720 × 480	Prog	N	N	ANALOG	YPbPr	EIA720 × 480pW@60	xvYCC 4% color bars	Color Bar xvYCC 4%
1007	44.96	59.94	74.176	1280 × 720	Prog	P	P	HDTV720	YPbPr	EIA1280 × 720p@59.94	xvYCC 8% color bars	Color Bar xvYCC 8%
1008	45.00	60.00	74.250	1280 × 720	Prog	P	P	HDTV720	YPbPr	EIA1280 × 720p@60	xvYCC 12% color bars	Color Bar xvYCC 12%
1009	33.72	59.94	74.176	1920 × 1080	Int	P	P	HDTV1080	YPbPr	EIA1920 × 1080i@59.94	100%/100% color bars, horizontal direction 2	Color Bar 100/100-H2
1010	33.75	60.00	74.250	1920 × 1080	Int	P	P	HDTV1080	YPbPr	EIA1920 × 1080i@60		
1011	15.73	59.94	27.000	1440 × 480	Int	N	N	ANALOG	YPbPr	EIA1440 × 480i@59.94		
1012	15.75	60.00	27.028	1440 × 480	Int	N	N	ANALOG	YPbPr	EIA1440 × 480i@60		
1013	15.73	59.94	27.000	1440 × 480	Int	N	N	ANALOG	YPbPr	EIA1440 × 480iW@59.94		
1014	15.75	60.00	27.028	1440 × 480	Int	N	N	ANALOG	YPbPr	EIA1440 × 480iW@60		
1015	15.73	60.05	27.000	1440 × 240	Prog	N	N	ANALOG	YPbPr	EIA1440 × 240p@59.94		
1016	15.75	60.12	27.028	1440 × 240	Prog	N	N	ANALOG	YPbPr	EIA1440 × 240p@60		
1017	15.73	59.83	27.000	1440 × 240	Prog	N	N	ANALOG	YPbPr	EIA1440 × 240p@59.94		
1018	15.75	59.89	27.028	1440 × 240	Prog	N	N	ANALOG	YPbPr	EIA1440 × 240p@60		
1019	15.73	60.05	27.000	1440 × 240	Prog	N	N	ANALOG	YPbPr	EIA1440 × 240pW@59.94		
1020	15.75	60.12	27.028	1440 × 240	Prog	N	N	ANALOG	YPbPr	EIA1440 × 240pW@60		

Internal program data: No. 1001 to 1020

Program No.	Horizontal frequency [KHz]	Vertical frequency [Hz]	Dot clock frequency [MHz]	No. of display dots (H × V)	Int / Prog	Sync polarity		SyncType	Color difference	Timing data name	Pattern data	Pattern data name
						H	V					
1021	15.73	59.83	27.000	1440 × 240	Prog	N	N	ANALOG	YPbPr	EIA1440 × 240pW@59.94		
1022	15.75	59.89	27.028	1440 × 240	Prog	N	N	ANALOG	YPbPr	EIA1440 × 240pW@60		
1023	15.73	59.94	54.000	2880 × 480	Int	N	N	ANALOG	YPbPr	EIA2880 × 480i@59.94		
1024	15.75	60.00	54.054	2880 × 480	Int	N	N	ANALOG	YPbPr	EIA2880 × 480i@60		
1025	15.73	59.94	54.000	2880 × 480	Int	N	N	ANALOG	YPbPr	EIA2880 × 480iW@59.94		
1026	15.75	60.00	54.054	2880 × 480	Int	N	N	ANALOG	YPbPr	EIA2880 × 480iW@60		
1027	15.73	60.05	54.000	2880 × 240	Prog	N	N	ANALOG	YPbPr	EIA2880 × 240p@59.94		
1028	15.75	60.11	54.054	2880 × 240	Prog	N	N	ANALOG	YPbPr	EIA2880 × 240p@60		
1029	15.73	59.83	54.000	2880 × 240	Prog	N	N	ANALOG	YPbPr	EIA2880 × 240p@59.94		
1030	15.75	59.89	54.054	2880 × 240	Prog	N	N	ANALOG	YPbPr	EIA2880 × 240p@59.94		
1031	15.73	60.05	54.000	2880 × 240	Prog	N	N	ANALOG	YPbPr	EIA2880 × 240pW@59.94	Gray scale, horizontal direction (4 steps)	Gray Scale H-4step
1032	15.75	60.11	54.054	2880 × 240	Prog	N	N	ANALOG	YPbPr	EIA2880 × 240pW@60	Gray scale, horizontal direction (8 steps)	Gray Scale H-8step
1033	15.73	59.83	54.000	2880 × 240	Prog	N	N	ANALOG	YPbPr	EIA2880 × 240pW@59.94	Gray scale, horizontal direction (16 steps)	Gray Scale H-16step
1034	15.75	59.89	54.054	2880 × 240	Prog	N	N	ANALOG	YPbPr	EIA2880 × 240pW@60	Gray scale, horizontal direction (32 steps)	Gray Scale H-32step
1035	31.47	59.94	54.000	1440 × 480	Prog	N	N	ANALOG	YPbPr	EIA1440 × 480p@59.94	Gray scale, horizontal direction (64 steps)	Gray Scale H-64step
1036	31.50	60.00	54.054	1440 × 480	Prog	N	N	ANALOG	YPbPr	EIA1440 × 480p@60	Gray scale, horizontal direction (128 steps)	Gray Scale H-128step
1037	31.47	59.94	54.000	1440 × 480	Prog	N	N	ANALOG	YPbPr	EIA1440 × 480pW@59.94	Gray scale, horizontal direction (256 steps)	Gray Scale H-256step
1038	31.50	60.00	54.054	1440 × 480	Prog	N	N	ANALOG	YPbPr	EIA1440 × 480pW@60	Gray scale, vertical direction (4 steps)	Gray Scale V-4step
1039	67.43	59.94	148.352	1920 × 1080	Prog	P	P	HDTV1080	YPbPr	EIA1920 × 1080p@59.94	Gray scale, vertical direction (8 steps)	Gray Scale V-8step
1040	67.50	60.00	148.500	1920 × 1080	Prog	P	P	HDTV1080	YPbPr	EIA1920 × 1080p@60	Gray scale, vertical direction (16 steps)	Gray Scale V-16step

Internal program data: No. 1021 to 1040

Program No.	Horizontal frequency [KHz]	Vertical frequency [Hz]	Dot clock frequency [MHz]	No. of display dots (H × V)	Int / Prog	Sync polarity		SyncType	Color difference	Timing data name	Pattern data	Pattern data name
						H	V					
1041	31.25	50.00	27.000	720 × 576	Prog	N	N	ANALOG	YPbPr	EIA720 × 576p@50	Gray scale, vertical direction (32 steps)	Gray Scale V-32step
1042	31.25	50.00	27.000	720 × 576	Prog	N	N	ANALOG	YPbPr	EIA720 × 576pW@50	Gray scale, vertical direction (64 steps)	Gray Scale V-64step
1043	37.50	50.00	74.250	1280 × 720	Prog	P	P	HDTV720	YPbPr	EIA1280 × 720p@50	Gray scale, vertical direction (128 steps)	Gray Scale V-128step
1044	28.13	50.00	74.250	1920 × 1080	Int	P	P	HDTV1080	YPbPr	EIA1920 × 1080i@50	Gray scale, vertical direction (256 steps)	Gray Scale V-256step
1045	15.63	50.00	27.000	1440 × 576	Int	N	N	ANALOG	YPbPr	EIA1440 × 576i@50	Linear ramp, horizontal direction	Ramp Linear-H
1046	15.63	50.00	27.000	1440 × 576	Int	N	N	ANALOG	YPbPr	EIA1440 × 576iW@50	Linear ramp, vertical direction	Ramp Linear-V
1047	15.63	50.08	27.000	1440 × 288	Prog	N	N	ANALOG	YPbPr	EIA1440 × 288p@50	Linear ramp, horizontal and vertical directions	Ramp Linear-HV
1048	15.63	49.92	27.000	1440 × 288	Prog	N	N	ANALOG	YPbPr	EIA1440 × 288p@50		Ramp Linear-H RGBW-H
1049	15.63	49.76	27.000	1440 × 288	Prog	N	N	ANALOG	YPbPr	EIA1440 × 288p@50		Ramp Linear-V RGBW-V
1050	15.63	50.08	27.000	1440 × 288	Prog	N	N	ANALOG	YPbPr	EIA1440 × 288pW@50		Ramp Linear-H RGBW-V
1051	15.63	49.92	27.000	1440 × 288	Prog	N	N	ANALOG	YPbPr	EIA1440 × 288pW@50	Turn ramp	Ramp-H 1Level/dot
1052	15.63	49.76	27.000	1440 × 288	Prog	N	N	ANALOG	YPbPr	EIA1440 × 288pW@50		
1053	15.63	50.00	54.000	2880 × 576	Int	N	N	ANALOG	YPbPr	EIA2880 × 576i@50		Ramp Linear H:G V:R
1054	15.63	50.00	54.000	2880 × 576	Int	N	N	ANALOG	YPbPr	EIA2880 × 576iW@50		Ramp Linear H:B V:R
1055	15.63	50.08	54.000	2880 × 288	Prog	N	N	ANALOG	YPbPr	EIA2880 × 288p@50		Ramp Linear H:B V:G
1056	15.63	49.92	54.000	2880 × 288	Prog	N	N	ANALOG	YPbPr	EIA2880 × 288p@50		Ramp Linear H:R V:G
1057	15.63	49.76	54.000	2880 × 288	Prog	N	N	ANALOG	YPbPr	EIA2880 × 288p@50		Ramp Linear H:R V:B
1058	15.63	50.08	54.000	2880 × 288	Prog	N	N	ANALOG	YPbPr	EIA2880 × 288pW@50		Ramp Linear H:G V:B
1059	15.63	49.92	54.000	2880 × 288	Prog	N	N	ANALOG	YPbPr	EIA2880 × 288pW@50	128-step gray scale ramp (top: R → L, bottom: R ← L)	Ramp 128 R->L L->R
1060	15.63	49.76	54.000	2880 × 288	Prog	N	N	ANALOG	YPbPr	EIA2880 × 288pW@50	256-step gray scale ramp (top: R → L, bottom: R ← L)	Ramp 256 R->L L->R

Internal program data: No. 1041 to 1060

Program No.	Horizontal frequency [KHz]	Vertical frequency [Hz]	Dot clock frequency [MHz]	No. of display dots (H × V)	Int / Prog	Sync polarity		SyncType	Color difference	Timing data name	Pattern data	Pattern data name
						H	V					
1061	31.25	50.00	54.000	1440 × 576	Prog	N	N	ANALOG	YPbPr	EIA1440 × 576p@50		
1062	31.25	50.00	54.000	1440 × 576	Prog	N	N	ANALOG	YPbPr	EIA1440 × 576pW@50		
1063	56.25	50.00	148.500	1920 × 1080	Prog	P	P	HDTV1080	YPbPr	EIA1920 × 1080p@50		
1064	26.97	23.98	74.176	1920 × 1080	Prog	P	P	HDTV1080	YPbPr	EIA1920 × 1080p@23.97		
1065	27.00	24.00	74.250	1920 × 1080	Prog	P	P	HDTV1080	YPbPr	EIA1920 × 1080p@24		
1066	28.13	25.00	74.250	1920 × 1080	Prog	P	P	HDTV1080	YPbPr	EIA1920 × 1080p@25		
1067	33.72	29.97	74.176	1920 × 1080	Prog	P	P	HDTV1080	YPbPr	EIA1920 × 1080p@29.97		
1068	33.75	30.00	74.250	1920 × 1080	Prog	P	P	HDTV1080	YPbPr	EIA1920 × 1080p@30		
1069	31.47	59.94	108.000	2880 × 480	Prog	N	N	ANALOG	YPbPr	EIA2880 × 480p@59.94		
1070	31.50	60.00	108.108	2880 × 480	Prog	N	N	ANALOG	YPbPr	EIA2880 × 480p@60		
1071	31.47	59.94	108.000	2880 × 480	Prog	N	N	ANALOG	YPbPr	EIA2880 × 480pW@59.94	Linear ramp, horizontal direction + scroll	Ramp Linear-H Scroll
1072	31.50	60.00	108.108	2880 × 480	Prog	N	N	ANALOG	YPbPr	EIA2880 × 480pW@60	Linear ramp, vertical direction + scroll	Ramp Linear-V Scroll
1073	31.25	50.00	108.000	2880 × 576	Prog	N	N	ANALOG	YPbPr	EIA2880 × 576p@50	Linear ramp, horizontal and vertical directions + scroll	Ramp Linear-HV Scroll
1074	31.25	50.00	108.000	2880 × 576	Prog	N	N	ANALOG	YPbPr	EIA2880 × 576pW@50		
1075	31.25	50.00	72.000	1920 × 1080	Int	P	N	HDTV1250 (AUS)	YPbPr	EIA1920 × 1080i@50		
1076	56.25	100.00	148.500	1920 × 1080	Int	P	P	HDTV1080	YPbPr	EIA1920 × 1080i@100		
1077	75.00	100.00	148.500	1280 × 720	Prog	P	P	HDTV720	YPbPr	EIA1280 × 720p@100		
1078	62.50	100.00	54.000	720 × 576	Prog	N	N	ANALOG	YPbPr	EIA720 × 576p@100		
1079	62.50	100.00	54.000	720 × 576	Prog	N	N	ANALOG	YPbPr	EIA720 × 576pW@100		
1080	31.25	100.00	54.000	1440 × 576	Int	N	N	ANALOG	YPbPr	EIA1440 × 576i@100		

Internal program data: No. 1061 to 1080

Program No.	Horizontal frequency [KHz]	Vertical frequency [Hz]	Dot clock frequency [MHz]	No. of display dots (H × V)	Int / Prog	Sync polarity		SyncType	Color difference	Timing data name	Pattern data	Pattern data name
						H	V					
1081	31.25	100.00	54.000	1440 × 576	Int	N	N	ANALOG	YPbPr	EIA1440 × 576iW@100		
1082	67.43	119.88	148.352	1920 × 1080	Int	P	P	HDTV1080	YPbPr	EIA1920 × 1080i@119.88		
1083	67.50	120.00	148.500	1920 × 1080	Int	P	P	HDTV1080	YPbPr	EIA1920 × 1080i@120		
1084	89.91	119.88	148.352	1280 × 720	Prog	P	P	HDTV720	YPbPr	EIA1280 × 720p@119.88		
1085	90.00	120.00	148.500	1280 × 720	Prog	P	P	HDTV720	YPbPr	EIA1280 × 720p@120		
1086	62.94	119.88	54.000	720 × 480	Prog	N	N	ANALOG	YPbPr	EIA720 × 480p@119.88		
1087	63.00	120.00	54.054	720 × 480	Prog	N	N	ANALOG	YPbPr	EIA720 × 480p@120		
1088	62.94	119.88	54.000	720 × 480	Prog	N	N	ANALOG	YPbPr	EIA720 × 480pW@119.88		
1089	63.00	120.00	54.054	720 × 480	Prog	N	N	ANALOG	YPbPr	EIA720 × 480pW@120		
1090	31.47	119.88	54.000	1440 × 480	Int	N	N	ANALOG	YPbPr	EIA1440 × 480i@119.88		
1091	31.50	120.00	54.054	1440 × 480	Int	N	N	ANALOG	YPbPr	EIA1440 × 480i@120		
1092	31.47	119.88	54.000	1440 × 480	Int	N	N	ANALOG	YPbPr	EIA1440 × 480iW@119.88		
1093	31.50	120.00	54.054	1440 × 480	Int	N	N	ANALOG	YPbPr	EIA1440 × 480iW@120		
1094	125.00	200.00	108.000	720 × 576	Prog	N	N	ANALOG	YPbPr	EIA720 × 576p@200		
1095	125.00	200.00	108.000	720 × 576	Prog	N	N	ANALOG	YPbPr	EIA720 × 576pW@200		
1096	62.50	200.00	108.000	1440 × 576	Int	N	N	ANALOG	YPbPr	EIA1440 × 576i@200		
1097	62.50	200.00	108.000	1440 × 576	Int	N	N	ANALOG	YPbPr	EIA1440 × 576iW@200		
1098	125.87	239.76	108.000	720 × 480	Prog	N	N	ANALOG	YPbPr	EIA720 × 480p@239.76		
1099	126.00	240.00	108.108	720 × 480	Prog	N	N	ANALOG	YPbPr	EIA720 × 480p@240		
1100	125.87	239.76	108.000	720 × 480	Prog	N	N	ANALOG	YPbPr	EIA720 × 480pW@239.76		

Internal program data: No. 1081 to 1100



Program No.	Horizontal frequency [KHz]	Vertical frequency [Hz]	Dot clock frequency [MHz]	No. of display dots (H × V)	Int / Prog	Sync polarity		SyncType	Color difference	Timing data name	Pattern data	Pattern data name
						H	V					
1101	126.00	240.00	108.108	720 × 480	Prog	N	N	ANALOG	YPbPr	EIA720 × 480pW@240	Multi burst 100%	Multi Burst 100%
1102	62.94	239.76	108.000	1440 × 480	Int	N	N	ANALOG	YPbPr	EIA1440 × 480i@239.76	Multi burst 50%	Multi Burst 50%
1103	63.00	240.00	108.108	1440 × 480	Int	N	N	ANALOG	YPbPr	EIA1440 × 480i@240	Sweep pattern	Sweep
1104	62.94	239.76	108.000	1440 × 480	Int	N	N	ANALOG	YPbPr	EIA1440 × 480iW@239.76	APDC pattern	APDC
1105	63.00	240.00	108.108	1440 × 480	Int	N	N	ANALOG	YPbPr	EIA1440 × 480iW@240		
1106												
1107												
1108												
1109												
1110												
1111											OPT38 (SMPTE RP-133)	SMPTE RP-133
1112											OPT39 (SMPTE color version)	SMPTE RP-133+Color
1113											Monoscope	Monoscope
1114											Philips pattern	Philips
1115											Chinese monoscope	China Monoscope
1116											APDC1	APDC1
1117											APDC2	APDC2
1118											APDC3	APDC3
1119											APDC4	APDC4
1120											APDC5	APDC5

Internal program data: No. 1101 to 1120

* Programs No. 1116 to 1119 require license registration. When the license is not input, a license error results. For information on purchasing a license, contact ASTRODESIGN sales.

Program No.	Horizontal frequency [KHz]	Vertical frequency [Hz]	Dot clock frequency [MHz]	No. of display dots (H × V)	Int / Prog	Sync polarity		SyncType	Color difference	Timing data name	Pattern data	Pattern data name
						H	V					
1121											White solid	Raster White
1122											Red solid	Raster Red
1123											Green solid	Raster Green
1124											Blue solid	Raster Blue
1125											Black solid	Raster Black
1126											50% solid gray	Raster 50%Gray
1127											Magenta solid	Raster Magenta
1128											Cyan solid	Raster Cyan
1129											Yellow solid	Raster Yellow
1130												
1131												
1132												
1133												
1134												
1135												
1136												
1137												
1138												
1139												
1140												

Internal program data: No. 1121 to 1140



Program No.	Horizontal frequency [KHz]	Vertical frequency [Hz]	Dot clock frequency [MHz]	No. of display dots (H × V)	Int / Prog	Sync polarity		SyncType	Color difference	Timing data name	Pattern data	Pattern data name
						H	V					
1141											Overscan pattern	Over Scan
1142											AFD pattern 4:3 Type 0	AFD 4:3 Type0
1143											AFD pattern 4:3 Type 1	AFD 4:3 Type1
1144											AFD pattern 4:3 Type 2	AFD 4:3 Type2
1145											AFD pattern 4:3 Type 3	AFD 4:3 Type3
1146											AFD pattern 4:3 Type 4	AFD 4:3 Type4
1147											AFD pattern 4:3 Type 5	AFD 4:3 Type5
1148											AFD pattern 4:3 Type 6	AFD 4:3 Type6
1149											AFD pattern 4:3 Type 7	AFD 4:3 Type7
1150											AFD pattern 4:3 Type 8	AFD 4:3 Type8
1151	31.47	59.94	27.000	720 × 480	Prog	N	N	ANALOG	YPbPr	EIA480p59-YCC-12	AFD pattern 4:3 Type 9	AFD 4:3 Type9
1152	33.72	59.94	74.176	1920 × 1080	Int	P	P	HDTV1080	YPbPr	EIA1080i59-YCC-12	AFD pattern 4:3 Type 10	AFD 4:3 Type10
1153	44.96	59.94	74.176	1280 × 720	Prog	P	P	HDTV720	YPbPr	EIA720p59-YCC-12	AFD pattern 4:3 Type 11	AFD 4:3 Type11
1154	31.47	59.94	25.175	640 × 480	Prog	N	N	ANALOG	RGB	EIA480p59-YCC-12	AFD pattern 4:3 Type 12	AFD 4:3 Type12
1155	67.43	59.94	148.352	1920 × 1080	Prog	P	P	HDTV1080	YPbPr	EIA1080p59-YCC-12	AFD pattern 16:9 Type 0	AFD 16:9 Type0
1156	15.73	59.94	27.000	1440 × 480	Int	N	N	ANALOG	YPbPr	EIA480i59-YCC-12	AFD pattern 16:9 Type 1	AFD 16:9 Type1
1157	27.00	24.00	74.250	1920 × 1080	Prog	P	P	HDTV1080	YPbPr	EIA1080p24-YCC-12	AFD pattern 16:9 Type 2	AFD 16:9 Type2
1158	31.25	50.00	27.000	720 × 576	Prog	N	N	ANALOG	YPbPr	EIA576p50-YCC-12	AFD pattern 16:9 Type 3	AFD 16:9 Type3
1159	28.13	50.00	74.250	1920 × 1080	Int	P	P	HDTV1080	YPbPr	EIA1080i50-YCC-12	AFD pattern 16:9 Type 4	AFD 16:9 Type4
1160	37.50	50.00	74.250	1280 × 720	Prog	P	P	HDTV720	YPbPr	EIA720p50-YCC-12	AFD pattern 16:9 Type 5	AFD 16:9 Type5

Internal program data: No. 1141 to 1160

Program No.	Horizontal frequency [KHz]	Vertical frequency [Hz]	Dot clock frequency [MHz]	No. of display dots (H × V)	Int / Prog	Sync polarity		SyncType	Color difference	Timing data name	Pattern data	Pattern data name
						H	V					
1161	56.25	50.00	148.500	1920 × 1080	Prog	P	P	HDTV1080	YPbPr	EIA1080p50-YCC-12	AFD pattern 16:9 Type 6	AFD 16:9 Type6
1162	15.63	50.00	27.000	1440 × 576	Int	N	N	ANALOG	YPbPr	EIA576i50-YCC-12	AFD pattern 16:9 Type 7	AFD 16:9 Type7
1163	28.13	25.00	74.250	1920 × 1080	Prog	P	P	HDTV1080	YPbPr	EIA1080p25-YCC-12	AFD pattern 16:9 Type 8	AFD 16:9 Type8
1164											AFD pattern 16:9 Type 9	AFD 16:9 Type9
1165											AFD pattern 16:9 Type 10	AFD 16:9 Type10
1166											AFD pattern 16:9 Type 11	AFD 16:9 Type11
1167											AFD pattern 16:9 Type 12	AFD 16:9 Type12
1168												
1169												
1170												
1171	31.47	59.94	27.000	720 × 480	Prog	N	N	ANALOG	YPbPr	EIA480p59-RGB-12		
1172	33.72	59.94	74.176	1920 × 1080	Int	P	P	HDTV1080	YPbPr	EIA1080i59-RGB-12		
1173	44.96	59.94	74.176	1280 × 720	Prog	P	P	HDTV720	YPbPr	EIA720p59-RGB-12		
1174	31.47	59.94	25.175	640 × 480	Prog	N	N	ANALOG	RGB	EIA480p59-RGB-12		
1175	67.43	59.94	148.352	1920 × 1080	Prog	P	P	HDTV1080	YPbPr	EIA1080p59-RGB-12		
1176	15.73	59.94	27.000	1440 × 480	Int	N	N	ANALOG	YPbPr	EIA480i59-RGB-12		
1177	27.00	24.00	74.250	1920 × 1080	Prog	P	P	HDTV1080	YPbPr	EIA1080p24-RGB-12		
1178	31.25	50.00	27.000	720 × 576	Prog	N	N	ANALOG	YPbPr	EIA576p50-RGB-12		
1179	28.13	50.00	74.250	1920 × 1080	Int	P	P	HDTV1080	YPbPr	EIA1080i50-RGB-12		
1180	37.50	50.00	74.250	1280 × 720	Prog	P	P	HDTV720	YPbPr	EIA720p50-RGB-12		

Internal program data: No. 1161 to 1180



Program No.	Horizontal frequency [KHz]	Vertical frequency [Hz]	Dot clock frequency [MHz]	No. of display dots (H × V)	Int / Prog	Sync polarity		SyncType	Color difference	Timing data name	Pattern data	Pattern data name
						H	V					
1181	56.25	50.00	148.500	1920 × 1080	Prog	P	P	HDTV1080	YPbPr	EIA1080p50-RGB-12		
1182	15.63	50.00	27.000	1440 × 576	Int	N	N	ANALOG	YPbPr	EIA576i50-RGB-12		
1183	28.13	25.00	74.250	1920 × 1080	Prog	P	P	HDTV1080	YPbPr	EIA1080p25-RGB-12		
1184												
1185												
1186												
1187												
1188												
1189												
1190												
1191	33.72	59.94	74.176	1920 × 1080	Int	P	P	HDTV1080	YPbPr	EIA1080i59-YCC-12-xv		
1192	44.96	59.94	74.176	1280 × 720	Prog	P	P	HDTV720	YPbPr	EIA720p59-YCC-12-xv		
1193	67.43	59.94	148.352	1920 × 1080	Prog	P	P	HDTV1080	YPbPr	EIA1080p59-YCC-12-xv		
1194	27.00	24.00	74.250	1920 × 1080	Prog	P	P	HDTV1080	YPbPr	EIA1080p24-YCC-12-xv		
1195	28.13	50.00	74.250	1920 × 1080	Int	P	P	HDTV1080	YPbPr	EIA1080i50-YCC-12-xv		
1196	37.50	50.00	74.250	1280 × 720	Prog	P	P	HDTV720	YPbPr	EIA720p50-YCC-12-xv	APDC-1 4K Mode 2	APDC-1 4K Mode 2
1197	56.25	50.00	148.500	1920 × 1080	Prog	P	P	HDTV1080	YPbPr	EIA1080p50-YCC-12-xv	APDC-2 4K Mode 2	APDC-2 4K Mode 2
1198	28.13	25.00	74.250	1920 × 1080	Prog	P	P	HDTV1080	YPbPr	EIA1080p25-YCC-12-xv	APDC-3 4K Mode 2	APDC-3 4K Mode 2
1199											APDC-4 4K Mode 2	APDC-4 4K Mode 2
1200											APDC-5 4K Mode 2	APDC-5 4K Mode 2

Internal program data: No. 1181 to 1200

Program No.	Horizontal frequency [KHz]	Vertical frequency [Hz]	Dot clock frequency [MHz]	No. of display dots (H × V)	Int / Prog	Sync polarity		SyncType	Color difference	Timing data name	Pattern data	Pattern data name
						H	V					
1201	134.87	59.94	296.704	1920x2205	Prog	P	P	ANALOG	YPbPr	3D 1080p60 FramePack	1-dot × 1-dot checker	Checker 1dot*1dot
1202	112.50	50.00	297.000	1920x2205	Prog	P	P	ANALOG	YPbPr	3D 1080p50 FramePack	2-dot × 1-dot checker	Checker 2dot*1dot
1203	67.43	29.97	148.352	1920x2205	Prog	P	P	ANALOG	YPbPr	3D 1080p30 FramePack	4-dot × 1-dot checker	Checker 4dot*1dot
1204	53.95	23.98	148.352	1920x2205	Prog	P	P	ANALOG	YPbPr	3D 1080p24 FramePack	4 × 4 checker	Checker 4*4
1205	67.43	29.97	148.352	1920x2228	Prog	P	P	ANALOG	YPbPr	3D 1080i60 FramePack	8 × 8 checker	Checker 8*8
1206	56.25	25.00	148.500	1920x2228	Prog	P	P	ANALOG	YPbPr	3D 1080i50 FramePack	Sub-pixel checker	SubPixel
1207	89.91	59.94	148.352	1280x1470	Prog	P	P	ANALOG	YPbPr	3D 720p60 FramePack		
1208	75.00	50.00	148.500	1280x1470	Prog	P	P	ANALOG	YPbPr	3D 720p50 FramePack		
1209	44.96	29.97	148.352	1280x1470	Prog	P	P	ANALOG	YPbPr	3D 720p30 FramePack		
1210	35.96	23.98	118.681	1280x1470	Prog	P	P	ANALOG	YPbPr	3D 720p24 FramePack		
1211	62.94	59.94	54.000	720x1005	Prog	N	N	ANALOG	YPbPr	3D 480p60 FramePack		
1212	31.47	29.97	54.000	1440x1028	Prog	N	N	ANALOG	YPbPr	3D 480i60 FramePack		
1213	62.50	50.00	54.000	720x1201	Prog	N	N	ANALOG	YPbPr	3D 576p50 FramePack		
1214	31.25	25.00	54.000	1440x1226	Prog	N	N	ANALOG	YPbPr	3D 576i50 FramePack		
1215	62.94	59.94	50.350	640x1005	Prog	N	N	ANALOG	RGB	3D VGAp60 FramePack		
1216	56.25	25.00	148.500	1920x2205	Prog	P	P	ANALOG	YPbPr	3D 1080p25 FramePack		
1217												
1218												
1219												
1220												

Internal program data: No. 1201 to 1220

* For program no. 1201 to 1216, the requisite license must be registered for the 3D Vendor Specific InfoFrame output. When the license is not input, a license error results.
For information on purchasing a license, contact ASTRODESIGN sales.



Program No.	Horizontal frequency [KHz]	Vertical frequency [Hz]	Dot clock frequency [MHz]	No. of display dots (H x V)	Int / Prog	Sync polarity		SyncType	Color difference	Timing data name	Pattern data	Pattern data name
						H	V					
1221	67.43	59.94	148.352	1920x1080	Prog	P	P	ANALOG	YPbPr	3D 1080p60 Side_half	Character list 7 x 9	Character List 7*9
1222	56.25	50.00	148.500	1920x1080	Prog	P	P	ANALOG	YPbPr	3D 1080p50 Side_half	Character H (5 x 7 / 10 x 14)	Character all H5*7
1223	33.72	29.97	74.176	1920x1080	Prog	P	P	ANALOG	YPbPr	3D 1080p30 Side_half	Character H (7 x 9 / 14 x 18)	Character all H7*9
1224	26.97	23.98	74.176	1920x1080	Prog	P	P	ANALOG	YPbPr	3D 1080p24 Side_half	Character H (16 x 16 / 32 x 32)	Character all H16*16
1225	33.72	59.94	74.176	1920x1080	Int	P	P	ANALOG	YPbPr	3D 1080i60 Side_half	Corner & center character H (5 x 7 / 10 x 14)	Chara Cor&Cen H5*7
1226	28.13	50.00	74.250	1920x1080	Int	P	P	ANALOG	YPbPr	3D 1080i50 Side_half	Corner & center character H (7 x 9 / 14 x 18)	Chara Cor&Cen H7*9
1227	44.96	59.94	74.176	1280x720	Prog	P	P	ANALOG	YPbPr	3D 720p60 Side_half	Corner & center character H (16 x 16 / 32 x 32)	Chara Cor&Cen H16*16
1228	37.50	50.00	74.250	1280x720	Prog	P	P	ANALOG	YPbPr	3D 720p50 Side_half	Chinese character "BI" (7 x 9 / 64 x 64)	Chara all Chinese
1229	22.48	29.97	74.176	1280x720	Prog	P	P	ANALOG	YPbPr	3D 720p30 Side_half	Character "me" 18 x 18	Chara all me
1230	17.98	23.98	59.341	1280x720	Prog	P	P	ANALOG	YPbPr	3D 720p24 Side_half	Character "me" 18 x 18 (VESA specifications)	Chara all me (VESA)
1231	31.47	59.94	27.000	720x480	Prog	N	N	ANALOG	YPbPr	3D 480p60 Side_half		
1232	15.73	59.94	27.000	1440x480	Int	N	N	ANALOG	YPbPr	3D 480i60 Side_half		
1233	31.25	50.00	27.000	720x576	Prog	N	N	ANALOG	YPbPr	3D 576p50 Side_half		
1234	15.63	50.00	27.000	1440x576	Int	N	N	ANALOG	YPbPr	3D 576i50 Side_half		
1235	31.47	59.94	25.175	640x480	Prog	N	N	ANALOG	RGB	3D VGAp60 Side_half		
1236	28.13	25.00	74.250	1920x1080	Prog	P	P	ANALOG	YPbPr	3D 1080p25 Side_half		
1237												
1238												
1239												
1240												

Internal program data: No. 1221 to 1240

* For program no. 1221 to 1236, the requisite license must be registered for the 3D Vendor Specific InfoFrame output. When the license is not input, a license error results.
 For information on purchasing a license, contact ASTRODESIGN sales.

Program No.	Horizontal frequency [KHz]	Vertical frequency [Hz]	Dot clock frequency [MHz]	No. of display dots (H × V)	Int / Prog	Sync polarity		SyncType	Color difference	Timing data name	Pattern data	Pattern data name
						H	V					
1241	67.43	59.94	148.352	1920x1080	Prog	P	P	ANALOG	YPbPr	3D 1080p60 Top&Bot	Crosshatch pattern	Cross Hatch
1242	56.25	50.00	148.500	1920x1080	Prog	P	P	ANALOG	YPbPr	3D 1080p50 Top&Bot		
1243	33.72	29.97	74.176	1920x1080	Prog	P	P	ANALOG	YPbPr	3D 1080p30 Top&Bot		
1244	26.97	23.98	74.176	1920x1080	Prog	P	P	ANALOG	YPbPr	3D 1080p24 Top&Bot		
1245	33.72	59.94	74.176	1920x1080	Int	P	P	ANALOG	YPbPr	3D 1080i60 Top&Bot		
1246	28.13	50.00	74.250	1920x1080	Int	P	P	ANALOG	YPbPr	3D 1080i50 Top&Bot		
1247	44.96	59.94	74.176	1280x720	Prog	P	P	ANALOG	YPbPr	3D 720p60 Top&Bot		
1248	37.50	50.00	74.250	1280x720	Prog	P	P	ANALOG	YPbPr	3D 720p50 Top&Bot		
1249	22.48	29.97	74.176	1280x720	Prog	P	P	ANALOG	YPbPr	3D 720p30 Top&Bot		
1250	17.98	23.98	59.341	1280x720	Prog	P	P	ANALOG	YPbPr	3D 720p24 Top&Bot		
1251	31.47	59.94	27.000	720x480	Prog	N	N	ANALOG	YPbPr	3D 480p60 Top&Bot	H=20, V=20 dot pattern	Dot H=20,V=20
1252	15.73	59.94	27.000	1440x480	Int	N	N	ANALOG	YPbPr	3D 480i60 Top&Bot	H=60, V=60 dot pattern	Dot H=60,V=60
1253	31.25	50.00	27.000	720x576	Prog	N	N	ANALOG	YPbPr	3D 576p50 Top&Bot		
1254	15.63	50.00	27.000	1440x576	Int	N	N	ANALOG	YPbPr	3D 576i50 Top&Bot		
1255	31.47	59.94	25.175	640x480	Prog	N	N	ANALOG	RGB	3D VGAp60 Top&Bot		
1256	28.13	25.00	74.250	1920x1080	Prog	P	P	ANALOG	YPbPr	3D 1080p25 Top&Bot		
1257												
1258												
1259												
1260												

Internal program data: No. 1241 to 1260

* For program no. 1241 to 1255, the requisite license must be registered for the 3D Vendor Specific InfoFrame output. When the license is not input, a license error results.
For information on purchasing a license, contact ASTRODESIGN sales.



Program No.	Horizontal frequency [KHz]	Vertical frequency [Hz]	Dot clock frequency [MHz]	No. of display dots (H x V)	Int / Prog	Sync polarity		SyncType	Color difference	Timing data name	Pattern data	Pattern data name
						H	V					
1261	67.43	59.94	296.704	3840x1080	Prog	P	P	ANALOG	YPbPr	3D 1080p60 Side_full	Edge marker pattern	Edge Marker
1262	56.25	50.00	297.000	3840x1080	Prog	P	P	ANALOG	YPbPr	3D 1080p50 Side_full	Diagonal line pattern	Diagonal Line
1263	33.72	29.97	148.352	3840x1080	Prog	P	P	ANALOG	YPbPr	3D 1080p30 Side_full	Center marker pattern	Center Marker
1264	26.97	23.98	148.352	3840x1080	Prog	P	P	ANALOG	YPbPr	3D 1080p24 Side_full		
1265	33.72	59.94	148.352	3840x1080	Int	P	P	ANALOG	YPbPr	3D 1080i60 Side_full		
1266	28.13	50.00	148.500	3840x1080	Int	P	P	ANALOG	YPbPr	3D 1080i50 Side_full		
1267	44.96	59.94	148.352	2560x720	Prog	P	P	ANALOG	YPbPr	3D 720p60 Side_full		
1268	37.50	50.00	148.500	2560x720	Prog	P	P	ANALOG	YPbPr	3D 720p50 Side_full		
1269	22.48	29.97	148.352	2560x720	Prog	P	P	ANALOG	YPbPr	3D 720p30 Side_full		
1270	17.98	23.98	118.681	2560x720	Prog	P	P	ANALOG	YPbPr	3D 720p24 Side_full		
1271	31.47	59.94	54.000	1440x480	Prog	N	N	ANALOG	YPbPr	3D 480p60 Side_full	Circle (Format 0)	Circle Format0
1272	15.73	59.94	54.000	2880x480	Int	N	N	ANALOG	YPbPr	3D 480i60 Side_full	Circle (Format 1)	Circle Format1
1273	31.25	50.00	54.000	1440x576	Prog	N	N	ANALOG	YPbPr	3D 576p50 Side_full	Circle (Format 2)	Circle Format2
1274	15.63	50.00	54.000	2880x576	Int	N	N	ANALOG	YPbPr	3D 576i50 Side_full	Circle (Format 3)	Circle Format3
1275	31.47	59.94	50.350	1280x480	Prog	N	N	ANALOG	RGB	3D VGAp60 Side_full	Circle (Format 4)	Circle Format4
1276											Circle (Format 5)	Circle Format5
1277											Circle (Format 6)	Circle Format6
1278												
1279												
1280												

Internal program data: No. 1261 to 1280

* For program no. 1261 to 1275, the requisite license must be registered for the 3D Vendor Specific InfoFrame output. When the license is not input, a license error results.
 For information on purchasing a license, contact ASTRODESIGN sales.

Program No.	Horizontal frequency [KHz]	Vertical frequency [Hz]	Dot clock frequency [MHz]	No. of display dots (H × V)	Int / Prog	Sync polarity		SyncType	Color difference	Timing data name	Pattern data	Pattern data name
						H	V					
1281											Burst L → R	Burst L->R
1282											Burst L ← R	Burst L<-R
1283											Burst L ← C → R	Burst L<-C->R
1284											Burst L → C ← R	Burst L->C<-R
1285											Burst T → B	Burst T->B
1286											Burst T ← B	Burst T<-B
1287											Burst T ← C → B	Burst T<-C->B
1288											Burst T → C ← B	Burst T->C<-B
1289												
1290												
1291												
1292												
1293												
1294												
1295												
1296												
1297												
1298												
1299												
1300												

Internal program data: No. 1281 to 1300



Program No.	Horizontal frequency [KHz]	Vertical frequency [Hz]	Dot clock frequency [MHz]	No. of display dots (H x V)	Int / Prog	Sync polarity		SyncType	Color difference	Timing data name	Pattern data	Pattern data name
						H	V					
1301	15.73	59.94	27.000	1440x487	Int	N	N	ANALOG	YPbPr	SD-SDI 487i@59.94	1 window	1 Window
1302	15.63	50.00	27.000	1440x576	Int	N	N	ANALOG	YPbPr	SD-SDI 576i@50	4 windows	4 Window
1303											9 windows	9 Window
1304											16 windows	16 Window
1305											25 windows	25 Window
1306											64 windows	64 Window
1307											3 windows, vertical direction	3 Window in V Row
1308											3 windows, horizontal direction	3 Window in H Row
1309											Window user position/center	User pos-Center
1310											Window user position/corner	User pos-Corner
1311	33.75	60.00	74.250	1920x1080	Int	P	P	HDTV1080	YPbPr	HD-SDI 1080@60i	Window scroll: Left	Window Scroll:Left
1312	33.72	59.94	74.176	1920x1080	Int	P	P	HDTV1080	YPbPr	HD-SDI 1080@59.94i	Window scroll: Right	Window Scroll:Right
1313	28.13	50.00	74.250	1920x1080	Int	P	P	HDTV1080	YPbPr	HD-SDI 1080@50i	Window scroll: Up	Window Scroll:Up
1314	33.75	60.00	74.250	1920x1080	Int	P	P	HDTV1080	YPbPr	HD-SDI 1080@30sf	Window scroll: Down	Window Scroll:Down
1315	33.72	59.94	74.176	1920x1080	Int	P	P	HDTV1080	YPbPr	HD-SDI 1080@29.97sf	Window scroll: Top left	Window Scroll:L Up
1316	28.13	50.00	74.250	1920x1080	Int	P	P	HDTV1080	YPbPr	HD-SDI 1080@25sf	Window scroll: Bottom left	Window Scroll:L Down
1317	27.00	48.00	74.250	1920x1080	Int	P	P	HDTV1080	YPbPr	HD-SDI 1080@24sf	Window scroll: Top right	Window Scroll:R Up
1318	26.97	47.96	74.176	1920x1080	Int	P	P	HDTV1080	YPbPr	HD-SDI 1080@23.98sf	Window scroll: Bottom right	Window Scroll:R Down
1319	45.00	60.00	74.250	1280x720	Prog	P	P	HDTV720	YPbPr	HD-SDI 720@60p	Window scroll L ↔ R	Window Scroll:L<->R
1320	44.96	59.94	74.176	1280x720	Prog	P	P	HDTV720	YPbPr	HD-SDI 720@59.94p	Window scroll: Up ↔ down	Window Scroll:Up<->D

Internal program data: No. 1301 to 1320

Program No.	Horizontal frequency [KHz]	Vertical frequency [Hz]	Dot clock frequency [MHz]	No. of display dots (H × V)	Int / Prog	Sync polarity		SyncType	Color difference	Timing data name	Pattern data	Pattern data name
						H	V					
1321	22.50	30.00	74.250	1280x720	Prog	P	P	HDTV720	YPbPr	HD-SDI 720@30p	Window scroll: Random	Window Scroll:Random
1322	22.48	29.97	74.176	1280x720	Prog	P	P	HDTV720	YPbPr	HD-SDI 720@29.97p	Window + monoscope	Window & Monoscope
1323	18.75	25.00	74.250	1280x720	Prog	P	P	HDTV720	YPbPr	HD-SDI 720@25p	Window: 2-3 pull-down	Window 2-3pull down
1324	18.00	24.00	74.250	1280x720	Prog	P	P	HDTV720	YPbPr	HD-SDI 720@24p	0% window	Window HV Size 0%
1325	17.98	23.98	74.176	1280x720	Prog	P	P	HDTV720	YPbPr	HD-SDI 720@23.98p	5% window	Window HV Size 5%
1326	37.50	50.00	74.250	1280x720	Prog	P	P	HDTV720	YPbPr	HD-SDI 720@50p	10% window	Window HV Size 10%
1327											20% window	Window HV Size 20%
1328											30% window	Window HV Size 30%
1329											40% window	Window HV Size 40%
1330											50% window	Window HV Size 50%
1331	67.50	60.00	148.500	1920x1080	Prog	P	P	HDTV1080	YPbPr	3G-A 60p YC422 10b	60% window	Window HV Size 60%
1332	67.43	59.94	148.352	1920x1080	Prog	P	P	HDTV1080	YPbPr	3G-A 59p YC422 10b	70% window	Window HV Size 70%
1333	33.75	60.00	74.250	1920x1080	Int	P	P	HDTV1080	YPbPr	3G-A 60i RGB 12b	80% window	Window HV Size 80%
1334	33.72	59.94	74.176	1920x1080	Int	P	P	HDTV1080	YPbPr	3G-A 59i RGB 12b	90% window	Window HV Size 90%
1335	33.75	60.00	74.250	1920x1080	Int	P	P	HDTV1080	YPbPr	3G-A 60i YC444 12b	100% window	Window HV Size 100%
1336	33.72	59.94	74.176	1920x1080	Int	P	P	HDTV1080	YPbPr	3G-A 59i YC444 12b	Window: Flicker 1 V	Window Flicker 1 V
1337	33.75	60.00	74.250	1920x1080	Int	P	P	HDTV1080	YPbPr	3G-A 60i YC422 12b	Window: Flicker 2 V	Window Flicker 2 V
1338	33.72	59.94	74.176	1920x1080	Int	P	P	HDTV1080	YPbPr	3G-A 59i YC422 12b	Window: Flicker 3 V	Window Flicker 3 V
1339	27.00	24.00	74.250	2048x1080	Prog	P	P	ANALOG	YPbPr	3G-A DCI RGB 12b	Window: Flicker 4 V	Window Flicker 4 V
1340											Window: Level Up	Window Auto Level

Internal program data: No. 1321 to 1340



Program No.	Horizontal frequency [KHz]	Vertical frequency [Hz]	Dot clock frequency [MHz]	No. of display dots (HxV)	Int / Prog	Sync polarity		SyncType	Color difference	Timing data name	Pattern data	Pattern data name
						H	V					
1341	67.50	60.00	148.500	1920x1080	Prog	P	P	HDTV1080	YPbPr	3G-B 60p YC422 10b	Bar: L → R	Moving Bar
1342	67.43	59.94	148.352	1920x1080	Prog	P	P	HDTV1080	YPbPr	3G-B 59p YC422 10b		
1343	33.75	60.00	74.250	1920x1080	Int	P	P	HDTV1080	YPbPr	3G-B 60i RGB 12b		
1344	33.72	59.94	74.176	1920x1080	Int	P	P	HDTV1080	YPbPr	3G-B 59i RGB 12b		
1345	33.75	60.00	74.250	1920x1080	Int	P	P	HDTV1080	YPbPr	3G-B 60i YC444 12b		
1346	33.72	59.94	74.176	1920x1080	Int	P	P	HDTV1080	YPbPr	3G-B 59i YC444 12b		
1347	33.75	60.00	74.250	1920x1080	Int	P	P	HDTV1080	YPbPr	3G-B 60i YC422 12b		
1348	33.72	59.94	74.176	1920x1080	Int	P	P	HDTV1080	YPbPr	3G-B 59i YC422 12b		
1349	27.00	24.00	74.250	2048x1080	Prog	P	P	ANALOG	RGB	3G-B DCI RGB 12b		
1350												
1351	67.50	60.00	148.500	1920x1080	Prog	P	P	HDTV1080	YPbPr	Dual 60p YC422 10b		
1352	67.43	59.94	148.352	1920x1080	Prog	P	P	HDTV1080	YPbPr	Dual 59p YC422 10b		
1353	33.75	60.00	74.250	1920x1080	Int	P	P	HDTV1080	YPbPr	Dual 60i RGB 12b		
1354	33.72	59.94	74.176	1920x1080	Int	P	P	HDTV1080	YPbPr	Dual 59i RGB 12b		
1355	33.75	60.00	74.250	1920x1080	Int	P	P	HDTV1080	YPbPr	Dual 60i YC444 12b		
1356	33.72	59.94	74.176	1920x1080	Int	P	P	HDTV1080	YPbPr	Dual 59i YC444 12b		
1357	33.75	60.00	74.250	1920x1080	Int	P	P	HDTV1080	YPbPr	Dual 60i YC422 12b		
1358	33.72	59.94	74.176	1920x1080	Int	P	P	HDTV1080	YPbPr	Dual 59i YC422 12b		
1359	27.00	24.00	74.250	2048x1080	Prog	P	P	HDTV720	YPbPr	Dual DCI RGB 12b		
1360												

Internal program data: No. 1341 to 1360

Program No.	Horizontal frequency [KHz]	Vertical frequency [Hz]	Dot clock frequency [MHz]	No. of display dots (HxV)	Int / Prog	Sync polarity		SyncType	Color difference	Timing data name	Pattern data	Pattern data name
						H	V					
1361	56.25	50.00	148.500	1920x1080	Prog	P	P	HDTV1080	YPbPr	3G-A 50p YC422 10b		
1362	56.25	50.00	148.500	1920x1080	Prog	P	P	HDTV1080	YPbPr	3G-B 50p YC422 10b		
1363	56.25	50.00	148.500	1920x1080	Prog	P	P	HDTV1080	YPbPr	Dual 50p YC422 10b		
1364												
1365												
1366												
1367												
1368												
1369												
1370												
1371												
1372												
1373												
1374												
1375												
1376												
1377												
1378												
1379												
1380												

Internal program data: No. 1361 to 1380



Program No.	Horizontal frequency [KHz]	Vertical frequency [Hz]	Dot clock frequency [MHz]	No. of display dots (HxV)	Int / Prog	Sync polarity		SyncType	Color difference	Timing data name	Pattern data	Pattern data name
						H	V					
1381	135.00	60.00	594.000	3840x2160	Prog	P	P	HDTV1080	RGB	4K2K 3840x2160p60 s0		
1382	135.00	60.00	594.000	3840x2160	Prog	P	P	HDTV1080	RGB	4K2K 3840x2160p60 s1		
1383	135.00	60.00	594.000	3840x2160	Prog	P	P	HDTV1080	RGB	4K2K 3840x2160p60 s2		
1384	135.00	60.00	594.000	3840x2160	Prog	P	P	HDTV1080	RGB	4K2K 3840x2160p60 s3		
1385	270.00	120.00	1188.000	3840x2160	Prog	P	P	HDTV1080	RGB	4K2K 3840x2160p120s0		
1386	270.00	120.00	1188.000	3840x2160	Prog	P	P	HDTV1080	RGB	4K2K 3840x2160p120s1		
1387	270.00	120.00	1188.000	3840x2160	Prog	P	P	HDTV1080	RGB	4K2K 3840x2160p120s2		
1388	270.00	120.00	1188.000	3840x2160	Prog	P	P	HDTV1080	RGB	4K2K 3840x2160p120s3		
1389	67.43	29.97	296.703	3840x2160	Prog	P	P	ANALOG	YPbPr	4K2K 3840x2160p30		
1390	56.25	25.00	297.000	3840x2160	Prog	P	P	ANALOG	YPbPr	4K2K 3840x2160p25		
1391	53.95	23.98	296.703	3840x2160	Prog	P	P	ANALOG	YPbPr	4K2K 3840x2160p24		
1392	53.95	23.98	296.703	4096x2160	Prog	P	P	ANALOG	YPbPr	4K2K 4096x2160p24		
1393												
1394												
1395												
1396												
1397												
1398												
1399												
1400												

Internal program data: No. 1381 to 1400

Program No.	Horizontal frequency [KHz]	Vertical frequency [Hz]	Dot clock frequency [MHz]	No. of display dots (H × V)	Int / Prog	Sync polarity		SyncType	Color difference	Timing data name	Pattern data	Pattern data name
						H	V					
1401	31.47	59.94	27.000	720 × 483	Prog	N	N	ANALOG	YPbPr	NTSC PROG.	256-block color	256-Color Block
1402	31.47	59.94	27.000	720 × 483	Prog	N	N	ANALOG	YPbPr	NTSC PROG. W	64-gradation block gray (white → black)	64Gray Block White->
1403	31.47	59.94	27.000	720 × 483	Prog	N	N	ANALOG	YPbPr	NTSC PROG. LB	64-gradation block gray (black → white)	64Gray Block Black->
1404	33.72	59.94	74.176	1920 × 1080	Int	P	P	HDTV1080	YPbPr	1920 × 1080@59.94i	8 color bars & 16 gray scale	8-Color & 16-Gray
1405	33.75	60.00	74.250	1920 × 1080	Int	P	P	HDTV1080	YPbPr	1920 × 1080@60i	Gray scale & crosshatch	Gray & Cross Hatch
1406	67.43	59.94	148.352	1920 × 1080	Prog	P	P	HDTV1080	YPbPr	1920 × 1080@59.94p	Color bar & crosshatch	Color & Cross Hatch
1407	67.50	60.00	148.500	1920 × 1080	Prog	P	P	HDTV1080	YPbPr	1920 × 1080@60p	Color temperature	Color Temperature
1408	44.96	59.94	74.176	1280 × 720	Prog	P	P	HDTV720	YPbPr	1280 × 720@59.94p	Pairing	Pairing
1409	45.00	60.00	74.250	1280 × 720	Prog	P	P	HDTV720	YPbPr	1280 × 720@60p	Crosshatch & circle & gray	Cross&Circle&Gray
1410	15.73	59.94	13.500	712 × 484	Int	N	N	NTSC	YPbPr	NTSC-J 4:3	Crosshatch & circle & color bar & character	Cross&Circle&Color&H
1411											Circle & line	Circle & Line
1412											Character edge (H)	H-Character Line
1413											Character edge (O)	O-Character Line
1414											Crosstalk (width 90%)	Cross Talk W=90%
1415											Sine wave scroll	Sign Wave Scroll
1416	31.25	50.00	27.000	720 × 576	Prog	N	N	ANALOG	YPbPr	PAL PROG.	10 steps & 1/10 MHz	1/10 MHz × 10step
1417	31.25	50.00	27.000	720 × 576	Prog	N	N	ANALOG	YPbPr	PAL PROG. W	Gamma correction ramp $w\gamma = 2.5$	Gamma Ramp $wr=2.5$
1418	31.25	50.00	27.000	720 × 576	Prog	N	N	ANALOG	YPbPr	PAL PROG. LB	Gamma correction ramp $\gamma = 2.0$	Gamma Ramp $r=2.0$
1419	28.13	50.00	74.250	1920 × 1080	Int	P	P	HDTV1080	YPbPr	1920 × 1080@50i	Gamma correction ramp $\gamma = 0.5$	Gamma Ramp $r=0.5$
1420	56.25	50.00	148.500	1920 × 1080	Prog	P	P	HDTV1080	YPbPr	1920 × 1080@50p	SMPTE RP-27.1	SMPTE RP-27.1

Internal program data: No. 1401 to 1420



Program No.	Horizontal frequency [KHz]	Vertical frequency [Hz]	Dot clock frequency [MHz]	No. of display dots (H x V)	Int / Prog	Sync polarity		SyncType	Color difference	Timing data name	Pattern data	Pattern data name
						H	V					
1421	37.50	50.00	74.250	1280 x 720	Prog	P	P	HDTV720	YPbPr	1280 x 720@50p	ITC pattern 9 windows	ITC 9-Window
1422	15.63	50.00	13.500	702 x 574	Int	N	N	PAL	YPbPr	PAL 4:3	ITC pattern crosshatch & marker	ITC Cross & Marker
1423											ITC pattern H character	ITC H-Character
1424											64 gray + RGBW color bars superimposed	64-Gray & RGBW-Color
1425											Gray scale + circle	Gray & Circle
1426	33.72	29.97	74.176	1920 x 1080	Prog	P	P	HDTV1080	YPbPr	1920 x 1080@29.97p	Corner & center point marker	Corner&Center Marker
1427	33.75	30.00	74.250	1920 x 1080	Prog	P	P	HDTV1080	YPbPr	1920 x 1080@30p	Crosstalk (width 60%)	Cross Talk W=60%
1428	26.97	23.98	74.176	1920 x 1080	Prog	P	P	HDTV1080	YPbPr	1920 x 1080@23.98p	Song of Youth	SpeakerCheck / Youth
1429	27.00	24.00	74.250	1920 x 1080	Prog	P	P	HDTV1080	YPbPr	1920 x 1080@24p	Crosshatch & marker	Cross & Marker 1
1430	28.13	25.00	74.250	1920 x 1080	Prog	P	P	HDTV1080	YPbPr	1920 x 1080@25p	256-color block color "Color" letters	256-Color <Color>
1431	33.72	59.94	74.176	1920 x 1080	Int	P	P	HDTV1080	YPbPr	1920 x 1080@29.97sf	Random 256-color color bar	256-Color Random
1432	33.75	60.00	74.250	1920 x 1080	Int	P	P	HDTV1080	YPbPr	1920 x 1080@30sf	256-step gray scale & 7 color bars	256-Gray & 7-Color
1433	26.97	47.96	74.176	1920 x 1080	Int	P	P	HDTV1080	YPbPr	1920 x 1080@23.98sf	Center, corner window & edge marker	Corner&Center Window
1434	27.00	48.00	74.250	1920 x 1080	Int	P	P	HDTV1080	YPbPr	1920 x 1080@24sf	3-step gray scale window	3gray-Window
1435	28.13	50.00	74.250	1920 x 1080	Int	P	P	HDTV1080	YPbPr	1920 x 1080@25sf	19 x 15 crosshatch & marker	Cross & Marker 2
1436	22.48	29.97	74.176	1280 x 720	Prog	P	P	HDTV720	YPbPr	1280 x 720@29.97p	Crosshatch & circle	Circle & Cross Hatch
1437	22.50	30.00	74.250	1280 x 720	Prog	P	P	HDTV720	YPbPr	1280 x 720@30p	Checkerboard & window	1dotChecker & Window
1438	17.98	23.98	74.176	1280 x 720	Prog	P	P	HDTV720	YPbPr	1280 x 720@23.98p	ANSI pattern (Setup)	ANSI Setup
1439	18.00	24.00	74.250	1280 x 720	Prog	P	P	HDTV720	YPbPr	1280 x 720@24p	ANSI pattern (Contrast)	ANSI Contrast
1440	18.75	25.00	74.250	1280 x 720	Prog	P	P	HDTV720	YPbPr	1280 x 720@25p	ANSI pattern (9Point)	ANSI 9-Point

Internal program data: No. 1421 to 1440

Program No.	Horizontal frequency [KHz]	Vertical frequency [Hz]	Dot clock frequency [MHz]	No. of display dots (H × V)	Int / Prog	Sync polarity		SyncType	Color difference	Timing data name	Pattern data	Pattern data name
						H	V					
1441											ANSI pattern (H Resolution)	ANSI H-Resolution
1442											ANSI pattern (V Resolution)	ANSI V-Resolution
1443											Gamma correction ramp $\gamma = 2.2$	Gamma Ramp $r=2.2$
1444											Gamma correction ramp $\gamma = 0.45$	Gamma Ramp $r=0.45$
1445											Limited ramp in horizontal direction	
1446											Limited ramp in vertical direction	
1447												
1448												
1449												
1450												
1451	33.72	59.94	74.176	1920 × 1035	Int	P	P	HDTV1080	YPbPr	1920 × 1035@59.94i		
1452	33.75	60.00	74.250	1920 × 1035	Int	P	P	HDTV1080	YPbPr	1920 × 1035@60i		
1453	31.25	50.00	74.250	1920 × 1080	Int	N	N	HDTV1250	YPbPr	SMPTE295Mi		
1454	62.50	50.00	148.500	1920 × 1080	Prog	N	N	HDTV1250	YPbPr	SMPTE295Mp		
1455	31.25	50.00	48.000	1280 × 1152	Int	P	P	HDTV1152 (AUS)	YPbPr	AUS 1152i		
1456	31.25	50.00	72.000	1920 × 1080	Int	P	N	HDTV1250 (AUS)	YPbPr	AUS 1080i		
1457												
1458												
1459												
1460												

* Program numbers 1461 to 1480 are not registered.

Internal program data: No. 1441 to 1460



Program No.	Horizontal frequency [KHz]	Vertical frequency [Hz]	Dot clock frequency [MHz]	No. of display dots (HxV)	Int / Prog	Sync polarity		SyncType	Color difference	Timing data name	Pattern data	Pattern data name
						H	V					
1481											Motion blur 1	Motion Blur1
1482											Motion blur 2	Motion Blur2
1483											Motion blur 3	Motion Blur3
1484											Motion blur 4	Motion Blur4
1485											Motion blur 5	Motion Blur5
1486											Motion blur 6	Motion Blur6
1487											Motion blur 7	Motion Blur7
1488											Motion blur 8	Motion Blur8
1489											Motion blur 9	Motion Blur9
1490											Motion blur 10	Motion Blur10
1491											Motion blur 11	Motion Blur11
1492											Motion blur 12	Motion Blur12
1493												
1494												
1495												
1496												
1497												
1498												
1499												
1500												

Internal program data: No. 1481 to 1500

Program No.	Horizontal frequency [KHz]	Vertical frequency [Hz]	Dot clock frequency [MHz]	No. of display dots (H × V)	Int / Prog	Sync polarity		SyncType	Color difference	Timing data name	Pattern data	Pattern data name
						H	V					
1501	15.73	59.94	13.500	712 × 484	Int	N	N	NTSC	YPbPr	NTSC-J 4:3	Timing data	Timing Data
1502	15.73	59.94	13.500	712 × 484	Int	N	N	NTSC	YPbPr	NTSC-J 16:9		
1503	15.73	59.94	13.500	712 × 484	Int	N	N	NTSC	YPbPr	NTSC-J LB		
1504	15.63	50.00	13.500	702 × 574	Int	N	N	PAL	YPbPr	PAL 4:3		
1505	15.63	50.00	13.500	702 × 574	Int	N	N	PAL	YPbPr	PAL 16:9		
1506	15.63	50.00	13.500	702 × 574	Int	N	N	PAL	YPbPr	PAL LB		
1507	15.63	50.00	13.500	702 × 574	Int	N	N	SECAM	YPbPr	SECAM 4:3		
1508	15.63	50.00	13.500	702 × 574	Int	N	N	SECAM	YPbPr	SECAM 16:9		
1509	15.63	50.00	13.500	702 × 574	Int	N	N	SECAM	YPbPr	SECAM LB		
1510	15.73	59.94	13.500	712 × 484	Int	N	N	NTSC-M	YPbPr	NTSC-M		
1511	15.73	59.94	13.500	712 × 484	Int	N	N	NTSC-443	YPbPr	NTSC-443		HDCP On Screen
1512	15.73	59.94	13.500	712 × 484	Int	N	N	PAL-M	YPbPr	PAL-M		
1513	15.73	59.94	13.500	712 × 484	Int	N	N	PAL-60	YPbPr	PAL-60		
1514	15.63	50.00	13.500	718 × 572	Int	N	N	PAL-N	YPbPr	PAL-N		
1515	15.63	50.00	13.500	702 × 574	Int	N	N	PAL-Nc	YPbPr	PAL-Nc		
1516												
1517												
1518												
1519												
1520												

Internal program data: No. 1501 to 1520



Program No.	Horizontal frequency [KHz]	Vertical frequency [Hz]	Dot clock frequency [MHz]	No. of display dots (H × V)	Int / Prog	Sync polarity		SyncType	Color difference	Timing data name	Pattern data	Pattern data name
						H	V					
1521	15.73	59.94	13.500	712 × 484	Int	N	N	NTSC-M	YPbPr	Closed Caption CC1		HDMI Packet Data
1522	15.73	59.94	13.500	712 × 484	Int	N	N	NTSC-M	YPbPr	Closed Caption CC2		
1523	15.73	59.94	13.500	712 × 484	Int	N	N	NTSC-M	YPbPr	Closed Caption Text1		
1524	15.73	59.94	13.500	712 × 484	Int	N	N	NTSC-M	YPbPr	Closed Caption Text2		
1525	15.73	59.94	13.500	712 × 484	Int	N	N	NTSC-M	YPbPr	V Chip MPAA G		
1526	15.73	59.94	13.500	712 × 484	Int	N	N	NTSC-M	YPbPr	V Chip MPAA X		
1527	15.73	59.94	13.500	712 × 484	Int	N	N	NTSC-M	YPbPr	V Chip US TV-Y		
1528	15.73	59.94	13.500	712 × 484	Int	N	N	NTSC-M	YPbPr	V Chip US TV-MA-VSL		
1529												
1530												
1531	15.63	50.00	13.500	702 × 574	Int	N	N	PAL	YPbPr	PAL TELETEXT	EDID pattern DVI-1	EDID DVI1
1532											EDID pattern DVI-1 (HEX)	EDID DVI1 (HEX)
1533											EDID pattern DVI-2	EDID DVI2
1534											EDID pattern DVI-2 (HEX)	EDID DVI2 (HEX)
1535											EDID pattern HDMI1	EDID HDMI1
1536											EDID pattern HDMI1 (HEX)	EDID HDMI1 (HEX)
1537											EDID pattern HDMI2	EDID HDMI2
1538											EDID pattern HDMI2 (HEX)	EDID HDMI2 (HEX)
1539											EDID pattern PC-DVI	EDID PC-DVI
1540											EDID pattern PC-DVI (HEX)	EDID PC-DVI (HEX)

Internal program data: No. 1521 to 1540

Program No.	Horizontal frequency [KHz]	Vertical frequency [Hz]	Dot clock frequency [MHz]	No. of display dots (H × V)	Int / Prog	Sync polarity		SyncType	Color difference	Timing data name	Pattern data	Pattern data name
						H	V					
1541	15.73	59.94	13.500	712 × 484	Int	N	N	NTSC	YPbPr	Mac NTSC-J DVD Type1	EDID pattern PC-VGA	EDID PC-VGA
1542	15.73	59.94	13.500	712 × 484	Int	N	N	NTSC	YPbPr	Mac NTSC-J DVD Type2	EDID pattern PC-VGA (HEX)	EDID PC-VGA (HEX)
1543	15.73	59.94	13.500	712 × 484	Int	N	N	NTSC	YPbPr	Mac NTSC-J DVD Type3	EDID pattern TV-VGA	EDID TV-VGA
1544	15.63	50.00	13.500	702 × 574	Int	N	N	PAL	YPbPr	Mac PAL DVD	EDID pattern TV-VGA (HEX)	EDID TV-VGA (HEX)
1545												
1546												
1547												
1548												
1549												
1550												
1551	15.63	50.00	13.500	702 × 574	Int	N	N	PAL	YPbPr	SCART PAL VBS 4:3		
1552	15.63	50.00	13.500	702 × 574	Int	N	N	PAL	YPbPr	SCART PAL Y/C 4:3		
1553	15.63	50.00	13.500	702 × 574	Int	N	N	PAL	YPbPr	SCART PAL RGB 4:3		
1554	15.63	50.00	13.500	702 × 574	Int	N	N	PAL	YPbPr	SCART PAL VBS 16:9		
1555	15.63	50.00	13.500	702 × 574	Int	N	N	PAL	YPbPr	SCART PAL TELETEXT		
1556												
1557												
1558												
1559												
1560												

Internal program data: No. 1541 to 1560



Program No.	Horizontal frequency [KHz]	Vertical frequency [Hz]	Dot clock frequency [MHz]	No. of display dots (H × V)	Int / Prog	Sync polarity		SyncType	Color difference	Timing data name	Pattern data	Pattern data name
						H	V					
1561											DDC/CI pattern DVI-1 L-0	DDC/CI DVI1 L-0
1562											DDC/CI pattern DVI-1 L-100	DDC/CI DVI1 L-100
1563											DDC/CI pattern DVI-1 L-200	DDC/CI DVI1 L-200
1564											DDC/CI pattern DVI-2 L-0	DDC/CI DVI2 L-0
1565											DDC/CI pattern DVI-2 L-100	DDC/CI DVI2 L-100
1566											DDC/CI pattern DVI-2 L-200	DDC/CI DVI2 L-200
1567											DDC/CI pattern HDMI1 L-0	DDC/CI HDMI1 L-0
1568											DDC/CI pattern HDMI1 L-100	DDC/CI HDMI1 L-100
1569											DDC/CI pattern HDMI1 L-200	DDC/CI HDMI1 L-200
1570											DDC/CI pattern HDMI2 L-0	DDC/CI HDMI2 L-0
1571											DDC/CI pattern HDMI2 L-100	DDC/CI HDMI2 L-100
1572											DDC/CI pattern HDMI2 L-200	DDC/CI HDMI2 L-200
1573											DDC/CI pattern PC-DVI L-0	DDC/CI pcDVI L-0
1574											DDC/CI pattern PC-DVI L-100	DDC/CI pcDVI L-100
1575											DDC/CI pattern PC-DVI L-200	DDC/CI pcDVI L-200
1576											DDC/CI pattern PC-VGA L-0	DDC/CI pcVGA L-0
1577											DDC/CI pattern PC-VGA L-100	DDC/CI pcVGA L-100
1578											DDC/CI pattern PC-VGA L-200	DDC/CI pcVGA L-200
1579											DDC/CI pattern TV-VGA L-0	DDC/CI tvVGA L-0
1580											DDC/CI pattern TV-VGA L-100	DDC/CI tvVGA L-100
1581											DDC/CI pattern TV-VGA L-200	DDC/CI tvVGA L-200

Internal program data: No. 1561 to 1581

* Program numbers 1582 to 1600 are not registered.

Program No.	Horizontal frequency [KHz]	Vertical frequency [Hz]	Dot clock frequency [MHz]	No. of display dots (H × V)	Int / Prog	Sync polarity		SyncType	Color difference	Timing data name	Pattern data	Pattern data name
						H	V					
1601	37.86	85.08	31.500	640 × 350	Prog	P	N	ANALOG	RGB	VESA640 × 350@85		
1602	37.86	85.08	31.500	640 × 400	Prog	N	P	ANALOG	RGB	VESA640 × 400@85		
1603	37.93	85.04	35.500	720 × 400	Prog	N	P	ANALOG	RGB	VESA720 × 400@85		
1604	31.47	59.94	25.175	640 × 480	Prog	N	N	ANALOG	RGB	VESA640 × 480@60		
1605	37.86	72.81	31.500	640 × 480	Prog	N	N	ANALOG	RGB	VESA640 × 480@72		
1606	37.50	75.00	31.500	640 × 480	Prog	N	N	ANALOG	RGB	VESA640 × 480@75		
1607	43.27	85.01	36.000	640 × 480	Prog	N	N	ANALOG	RGB	VESA640 × 480@85		
1608	35.16	56.25	36.000	800 × 600	Prog	P	P	ANALOG	RGB	VESA800 × 600@56		
1609	37.88	60.32	40.000	800 × 600	Prog	P	P	ANALOG	RGB	VESA800 × 600@60		
1610	48.08	72.19	50.000	800 × 600	Prog	P	P	ANALOG	RGB	VESA800 × 600@72		
1611	46.88	75.00	49.500	800 × 600	Prog	P	P	ANALOG	RGB	VESA800 × 600@75		
1612	53.67	85.06	56.250	800 × 600	Prog	P	P	ANALOG	RGB	VESA800 × 600@85		
1613	76.30	119.97	73.250	800 × 600	Prog	P	N	ANALOG	RGB	VESA800 × 600@120CVT		
1614	31.02	60.00	33.750	848 × 480	Prog	P	P	ANALOG	RGB	VESA848 × 480@60		
1615	35.52	86.96	44.900	1024 × 768	Int	P	P	ANALOG	RGB	VESA1024 × 768@43		
1616	48.36	60.00	65.000	1024 × 768	Prog	N	N	ANALOG	RGB	VESA1024 × 768@60		
1617	56.48	70.07	75.000	1024 × 768	Prog	N	N	ANALOG	RGB	VESA1024 × 768@70		
1618	60.02	75.03	78.750	1024 × 768	Prog	P	P	ANALOG	RGB	VESA1024 × 768@75		
1619	68.68	85.00	94.500	1024 × 768	Prog	P	P	ANALOG	RGB	VESA1024 × 768@85		
1620	97.55	119.99	115.500	1024 × 768	Prog	P	N	ANALOG	RGB	VESA1024 × 768@120CVT		

Internal program data: No. 1601 to 1620



Program No.	Horizontal frequency [KHz]	Vertical frequency [Hz]	Dot clock frequency [MHz]	No. of display dots (H × V)	Int / Prog	Sync polarity		SyncType	Color difference	Timing data name	Pattern data	Pattern data name
						H	V					
1621	67.50	75.00	108.000	1152 × 864	Prog	P	P	ANALOG	RGB	VESA1152 × 864@75	CEC pattern HDMI1 Standby	CEC HDMI1 Standby
1622	47.40	59.99	68.250	1280 × 768	Prog	P	N	ANALOG	RGB	VESA1280 × 768@60	CEC pattern HDMI1 Im View On	CEC HDMI1 Im View On
1623	47.78	59.87	79.500	1280 × 768	Prog	N	P	ANALOG	RGB	VESA1280 × 768@60	CEC pattern HDMI1 Set OSD Nm	CEC HDMI1 Set OSD Nm
1624	60.29	74.89	102.250	1280 × 768	Prog	N	P	ANALOG	RGB	VESA1280 × 768@75	CEC pattern HDMI2 Standby	CEC HDMI2 Standby
1625	68.63	84.84	117.500	1280 × 768	Prog	N	P	ANALOG	RGB	VESA1280 × 768@85	CEC pattern HDMI2 Im View On	CEC HDMI2 Im View On
1626	97.40	119.80	140.250	1280 × 768	Prog	P	N	ANALOG	RGB	VESA1280 × 768@120CVT	CEC pattern HDMI2 Set OSD Nm	CEC HDMI2 Set OSD Nm
1627	49.31	59.91	71.000	1280 × 800	Prog	P	N	ANALOG	RGB	VESA1280 × 800@60CVT		
1628	49.70	59.81	83.500	1280 × 800	Prog	N	P	ANALOG	RGB	VESA1280 × 800@60		
1629	62.79	74.93	106.500	1280 × 800	Prog	N	P	ANALOG	RGB	VESA1280 × 800@75		
1630	71.55	84.88	122.500	1280 × 800	Prog	N	P	ANALOG	RGB	VESA1280 × 800@85		
1631	101.56	119.91	146.250	1280 × 800	Prog	P	N	ANALOG	RGB	VESA1280 × 800@120CVT		
1632	60.00	60.00	108.000	1280 × 960	Prog	P	P	ANALOG	RGB	VESA1280 × 960@60		
1633	85.94	85.00	148.500	1280 × 960	Prog	P	P	ANALOG	RGB	VESA1280 × 960@85		
1634	121.88	119.84	175.500	1280 × 960	Prog	P	N	ANALOG	RGB	VESA1280 × 960@120CVT		
1635	63.98	60.02	108.000	1280 × 1024	Prog	P	P	ANALOG	RGB	VESA1280 × 1024@60		
1636	79.98	75.02	135.000	1280 × 1024	Prog	P	P	ANALOG	RGB	VESA1280 × 1024@75		
1637	91.15	85.02	157.500	1280 × 1024	Prog	P	P	ANALOG	RGB	VESA1280 × 1024@85		
1638	130.03	119.96	187.250	1280 × 1024	Prog	P	N	ANALOG	RGB	VESA1280 × 1024@120CVT		
1639	47.71	60.02	85.500	1360 × 768	Prog	P	P	ANALOG	RGB	VESA1360 × 768@60		
1640	97.53	119.97	148.250	1360 × 768	Prog	P	N	ANALOG	RGB	VESA1360 × 768@120CVT		

Internal program data: No. 1621 to 1640

Program No.	Horizontal frequency [KHz]	Vertical frequency [Hz]	Dot clock frequency [MHz]	No. of display dots (H × V)	Int / Prog	Sync polarity		SyncType	Color difference	Timing data name	Pattern data	Pattern data name
						H	V					
1641	64.74	59.95	101.000	1400 × 1050	Prog	P	N	ANALOG	RGB	VESA1400 × 1050@60	3D window 4% L:W/R:W	3D W size 4% L:W R:W
1642	65.32	59.98	121.750	1400 × 1050	Prog	N	P	ANALOG	RGB	VESA1400 × 1050@60	3D window 4% L:W/R:B	3D W size 4% L:W R:B
1643	82.28	74.87	156.000	1400 × 1050	Prog	N	P	ANALOG	RGB	VESA1400 × 1050@75	3D window 4% L:B/R:B	3D W size 4% L:B R:B
1644	93.88	84.96	179.500	1400 × 1050	Prog	N	P	ANALOG	RGB	VESA1400 × 1050@85	3D window 4% L:B/R:W	3D W size 4% L:B R:W
1645	133.33	119.90	208.000	1400 × 1050	Prog	P	N	ANALOG	RGB	VESA1400 × 1050@120CVT	3D window 100% L:W/R:W	3D W size 100% L:W R:W
1646	55.47	59.90	88.750	1440 × 900	Prog	P	N	ANALOG	RGB	VESA1440 × 900@60CVT	3D window 100% L:W/R:B	3D W size 100% L:W R:B
1647	55.93	59.89	106.500	1440 × 900	Prog	N	P	ANALOG	RGB	VESA1440 × 900@60	3D window 100% L:B/R:B	3D W size 100% L:B R:B
1648	70.64	74.98	136.750	1440 × 900	Prog	N	P	ANALOG	RGB	VESA1440 × 900@75	3D window 100% L:B/R:W	3D W size 100% L:B R:W
1649	80.43	84.84	157.000	1440 × 900	Prog	N	P	ANALOG	RGB	VESA1440 × 900@85	3D raster L100%/R100%	3D Level L100% R100%
1650	114.22	119.85	182.750	1440 × 900	Prog	P	N	ANALOG	RGB	VESA1440 × 900@120CVT	3D raster L100%/R 75%	3D Level L100% R 75%
1651	75.00	60.00	162.000	1600 × 1200	Prog	P	P	ANALOG	RGB	VESA1600 × 1200@60	3D raster L100%/R 50%	3D Level L100% R 50%
1652	81.25	65.00	175.500	1600 × 1200	Prog	P	P	ANALOG	RGB	VESA1600 × 1200@65	3D raster L100%/R 25%	3D Level L100% R 25%
1653	87.50	70.00	189.000	1600 × 1200	Prog	P	P	ANALOG	RGB	VESA1600 × 1200@70	3D raster L100%/R 0%	3D Level L100% R 0%
1654	93.75	75.00	202.500	1600 × 1200	Prog	P	P	ANALOG	RGB	VESA1600 × 1200@75	3D raster L 0%/R100%	3D Level L 0% R100%
1655	106.25	85.00	229.500	1600 × 1200	Prog	P	P	ANALOG	RGB	VESA1600 × 1200@85	3D raster L 0%/R 75%	3D Level L 0% R 75%
1656	152.41	119.92	268.250	1600 × 1200	Prog	P	N	ANALOG	RGB	VESA1600 × 1200@120CVT	3D raster L 0%/R 50%	3D Level L 0% R 50%
1657	64.67	59.88	119.000	1680 × 1050	Prog	P	N	ANALOG	RGB	VESA1680 × 1050@60CVT	3D raster L 0%/R 25%	3D Level L 0% R 25%
1658	65.29	59.95	146.250	1680 × 1050	Prog	N	P	ANALOG	RGB	VESA1680 × 1050@60	3D raster L 0%/R 0%	3D Level L 0% R 0%
1659	82.31	74.89	187.000	1680 × 1050	Prog	N	P	ANALOG	RGB	VESA1680 × 1050@75	3D pattern cross hatch	3D Cross Hatch
1660	93.86	84.94	214.750	1680 × 1050	Prog	N	P	ANALOG	RGB	VESA1680 × 1050@85	3D pattern marker	3D Markers

Internal program data: No. 1641 to 1660



Program No.	Horizontal frequency [KHz]	Vertical frequency [Hz]	Dot clock frequency [MHz]	No. of display dots (H × V)	Int / Prog	Sync polarity		SyncType	Color difference	Timing data name	Pattern data	Pattern data name
						H	V					
1661	133.42	119.99	245.500	1680 × 1050	Prog	P	N	ANALOG	RGB	VESA1680 × 1050@120CVT	3D pattern 9 circle	3D 9 Circles
1662	83.64	60.00	204.750	1792 × 1344	Prog	N	P	ANALOG	RGB	VESA1792 × 1344@60	3D pattern color bar V-1	3D Color Bar V-1
1663	106.27	75.00	261.000	1792 × 1344	Prog	N	P	ANALOG	RGB	VESA1792 × 1344@75	3D pattern color bar V-2	3D Color Bar V-2
1664	170.72	119.97	333.250	1792 × 1344	Prog	P	N	ANALOG	RGB	VESA1792 × 1344@120CVT	3D pattern vertical	3D Vertical Bar
1665	86.33	60.00	218.250	1856 × 1392	Prog	N	P	ANALOG	RGB	VESA1856 × 1392@60	3D pattern checker dot	3D Checker Dot
1666	112.50	75.00	288.000	1856 × 1392	Prog	N	P	ANALOG	RGB	VESA1856 × 1392@75	3D pattern checker block	3D Checker Block
1667											3D Slant Color Bar	3D Slant Color Bar
1668	74.04	59.95	154.000	1920 × 1200	Prog	P	N	ANALOG	RGB	VESA1920 × 1200@60	3D Slant Gray Scale	3D Slant Gray Scale
1669	74.56	59.88	193.250	1920 × 1200	Prog	N	P	ANALOG	RGB	VESA1920 × 1200@60	3D Monoscope	3D Monoscope
1670	94.04	74.93	245.250	1920 × 1200	Prog	N	P	ANALOG	RGB	VESA1920 × 1200@75	3D Monoscope Offset	3D Monoscope Offset
1671	107.18	84.93	281.250	1920 × 1200	Prog	N	P	ANALOG	RGB	VESA1920 × 1200@85		
1672	152.40	119.91	317.000	1920 × 1200	Prog	P	N	ANALOG	RGB	VESA1920 × 1200@120CVT		
1673	90.00	60.00	234.000	1920 × 1440	Prog	N	P	ANALOG	RGB	VESA1920 × 1440@60		
1674	112.50	75.00	297.000	1920 × 1440	Prog	N	P	ANALOG	RGB	VESA1920 × 1440@75		
1675												
1676	98.71	59.97	268.500	2560 × 1600	Prog	P	N	ANALOG	RGB	VESA2560 × 1600@60CVT		
1677	47.71	59.79	85.500	1366 × 768	Prog	P	P	ANALOG	RGB	VESA1366 × 768@60		
1678	45.00	60.00	74.250	1280x720	Prog	P	P	ANALOG	RGB	VESA1280x720@60		
1679	48.00	60.00	72.000	1366x768	Prog	P	P	ANALOG	RGB	VESA1366x768@60		
1680	60.00	60.00	108.000	1600x900	Prog	P	P	ANALOG	RGB	VESA1600x900@60		

Internal program data: No. 1661 to 1680

Program No.	Horizontal frequency [KHz]	Vertical frequency [Hz]	Dot clock frequency [MHz]	No. of display dots (HxV)	Int / Prog	Sync polarity		SyncType	Color difference	Timing data name	Pattern data	Pattern data name
						H	V					
1681	67.50	60.00	148.50	1920x1080	Prog	P	P	ANALOG	RGB	VESA1920x1080@60		
1682	72.00	60.00	162.00	2048x1152	Prog	P	P	ANALOG	RGB	VESA2048x1152@60		
1683												
1684												
1685												
1686												
1687												
1688												
1689												
1690												
1691												
1692												
1693												
1694												
1695												
1696												
1697												
1698												
1699												
1700												

Internal program data: No. 1681 to 1700

* Program numbers 1701 to 1800 are not registered.

* The 3D timing data has been moved or added to program no. 1201 to 1275 when HDMI Specifications Ver.1.4a came to be supported. As a result, the data in program no. 1801 to 1848 was all deleted. The data stored in program no. 1801 to 1848 can be read and set using the SP-8870 software program provided as a standard accessory.

Program No.	Horizontal frequency [KHz]	Vertical frequency [Hz]	Dot clock frequency [MHz]	No. of display dots (HxV)	Int / Prog	Sync polarity		SyncType	Color difference	Timing data name	Pattern data	Pattern data name
						H	V					
1801	134.87	59.94	296.704	1920x2205	Prog	P	P	ANALOG	YPbPr	3D 1080p60 FramePack		
1802	112.50	50.00	297.000	1920x2205	Prog	P	P	ANALOG	YPbPr	3D 1080p50 FramePack		
1803	53.95	23.98	148.352	1920x2205	Prog	P	P	ANALOG	YPbPr	3D 1080p24 FramePack		
1804	67.43	29.97	148.352	1920x2228	Prog	P	P	ANALOG	YPbPr	3D 1080i60 FramePack		
1805	56.25	25.00	148.500	1920x2228	Prog	P	P	ANALOG	YPbPr	3D 1080i50 FramePack		
1806	89.91	59.94	148.352	1280x1470	Prog	P	P	ANALOG	YPbPr	3D 720p60 FramePack		
1807	75.00	50.00	148.500	1280x1470	Prog	P	P	ANALOG	YPbPr	3D 720p50 FramePack		
1808	62.94	59.94	54.000	720x1005	Prog	N	N	ANALOG	YPbPr	3D 480p60 FramePack		
1809	62.50	50.00	54.000	720x1201	Prog	N	N	ANALOG	YPbPr	3D 576p50 FramePack		
1810	31.47	29.97	54.000	1440x1028	Prog	N	N	ANALOG	YPbPr	3D 480i60 FramePack		
1811	31.25	25.00	54.000	1440x1226	Prog	N	N	ANALOG	YPbPr	3D 576i50 FramePack		
1812	62.94	59.94	50.350	640x1005	Prog	N	N	ANALOG	RGB	3D VGAp60 FramePack		
1813	67.43	59.94	148.352	1920x2206	Int	P	P	ANALOG	YPbPr	3D 1080i60 FieldAlte		
1814	56.25	50.00	148.500	1920x2206	Int	P	P	ANALOG	YPbPr	3D 1080i50 FieldAlte		
1815	31.47	59.94	54.000	1440x1006	Int	N	N	ANALOG	YPbPr	3D 480i60 FieldAlte		
1816	31.25	50.00	54.000	1440x1202	Int	N	N	ANALOG	YPbPr	3D 576i50 FieldAlte		
1817	134.87	59.94	296.704	1920x2160	Prog	P	P	ANALOG	YPbPr	3D 1080p60 LineAlter		
1818	112.50	50.00	297.000	1920x2160	Prog	P	P	ANALOG	YPbPr	3D 1080p50 LineAlter		
1819	53.95	23.98	148.352	1920x2160	Prog	P	P	ANALOG	YPbPr	3D 1080p24 LineAlter		
1820	89.91	59.94	148.352	1280x1440	Prog	P	P	ANALOG	YPbPr	3D 720p60 LineAlter		

Internal program data: No. 1801 to 1820

* The 3D timing data has been moved or added to program no. 1201 to 1275 when HDMI Specifications Ver.1.4a came to be supported. As a result, the data in program no. 1801 to 1848 was all deleted. The data stored in program no. 1801 to 1848 can be read and set using the SP-8870 software program provided as a standard accessory.

Program No.	Horizontal frequency [KHz]	Vertical frequency [Hz]	Dot clock frequency [MHz]	No. of display dots (HxV)	Int / Prog	Sync polarity		SyncType	Color difference	Timing data name	Pattern data	Pattern data name
						H	V					
1821	75.00	50.00	148.500	1280x1440	Prog	P	P	ANALOG	YPbPr	3D 720p50 LineAlter		
1822	62.94	59.94	54.000	720x960	Prog	N	N	ANALOG	YPbPr	3D 480p60 LineAlter		
1823	62.50	50.00	54.000	720x1152	Prog	N	N	ANALOG	YPbPr	3D 576p50 LineAlter		
1824	62.94	59.94	50.350	640x960	Prog	N	N	ANALOG	RGB	3D VGAp60 LineAlter		
1825	67.43	59.94	296.704	3840x1080	Prog	P	P	ANALOG	YPbPr	3D 1080p60 Side_full		
1826	56.25	50.00	297.000	3840x1080	Prog	P	P	ANALOG	YPbPr	3D 1080p50 Side_full		
1827	26.97	23.98	148.352	3840x1080	Prog	P	P	ANALOG	YPbPr	3D 1080p24 Side_full		
1828	33.72	59.94	148.352	3840x1080	Int	P	P	ANALOG	YPbPr	3D 1080i60 Side_full		
1829	28.13	50.00	148.500	3840x1080	Int	P	P	ANALOG	YPbPr	3D 1080i50 Side_full		
1830	44.96	59.94	148.352	2560x720	Prog	P	P	ANALOG	YPbPr	3D 720p60 Side_full		
1831	37.50	50.00	148.500	2560x720	Prog	P	P	ANALOG	YPbPr	3D 720p50 Side_full		
1832	31.47	59.94	54.000	1440x480	Prog	N	N	ANALOG	YPbPr	3D 480p60 Side_full		
1833	31.25	50.00	54.000	1440x576	Prog	N	N	ANALOG	YPbPr	3D 576p50 Side_full		
1834	15.73	59.94	54.000	2880x480	Int	N	N	ANALOG	YPbPr	3D 480i60 Side_full		
1835	15.63	50.00	54.000	2880x576	Int	N	N	ANALOG	YPbPr	3D 576i50 Side_full		
1836	31.47	59.94	50.350	1280x480	Prog	N	N	ANALOG	RGB	3D VGAp60 Side_full		
1837	67.43	59.94	148.352	1920x1080	Prog	P	P	ANALOG	YPbPr	3D 1080p60 Side_half		
1838	56.25	50.00	148.500	1920x1080	Prog	P	P	ANALOG	YPbPr	3D 1080p50 Side_half		
1839	26.97	23.98	74.176	1920x1080	Prog	P	P	ANALOG	YPbPr	3D 1080p24 Side_half		
1840	33.72	59.94	74.176	1920x1080	Int	P	P	ANALOG	YPbPr	3D 1080i60 Side_half		

Internal program data: No. 1821 to 1840



* The 3D timing data has been moved or added to program no. 1201 to 1275 when HDMI Specifications Ver.1.4a came to be supported. As a result, the data in program no. 1801 to 1848 was all deleted. The data stored in program no. 1801 to 1848 can be read and set using the SP-8870 software program provided as a standard accessory.

Program No.	Horizontal frequency [KHz]	Vertical frequency [Hz]	Dot clock frequency [MHz]	No. of display dots (HxV)	Int / Prog	Sync polarity		SyncType	Color difference	Timing data name	Pattern data	Pattern data name
						H	V					
1841	28.13	50.00	74.250	1920x1080	Int	P	P	ANALOG	YPbPr	3D 1080i50 Side_half		
1842	44.96	59.94	74.176	1280x720	Prog	P	P	ANALOG	YPbPr	3D 720p60 Side_half		
1843	37.50	50.00	74.250	1280x720	Prog	P	P	ANALOG	YPbPr	3D 720p50 Side_half		
1844	31.47	59.94	27.000	720x480	Prog	N	N	ANALOG	YPbPr	3D 480p60 Side_half		
1845	31.25	50.00	27.000	720x576	Prog	N	N	ANALOG	YPbPr	3D 576p50 Side_half		
1846	15.73	59.94	27.000	1440x480	Int	N	N	ANALOG	YPbPr	3D 480i60 Side_half		
1847	15.63	50.00	27.000	1440x576	Int	N	N	ANALOG	YPbPr	3D 576i50 Side_half		
1848	31.47	59.94	25.175	640x480	Prog	N	N	ANALOG	RGB	3D VGAp60 Side_half		
1849												

Internal program data: No. 1841 to 1848

Note: The 3D timing for sampling timing # 1801 to 1848 contain programs which are not written in HDMI Specification Ver.1.4. Sample timing may be changed in future by updates of the specification or standards. In the current Vblank3 period for field alternative, DE is HIGH. This spec is subject to change in future.

Program No.	Horizontal frequency [KHz]	Vertical frequency [Hz]	Dot clock frequency [MHz]	No. of display dots (H × V)	Int / Prog	Sync polarity		SyncType	Color difference	Timing data name	Pattern data	Pattern data name
						H	V					
1850	37.86	85.08	31.500	640 × 400	Prog	N	P	ANALOG	RGB	VESA400-85		
1851	37.86	72.81	31.500	640 × 480	Prog	N	N	ANALOG	RGB	VESA480-72		
1852	37.50	75.00	31.500	640 × 480	Prog	N	N	ANALOG	RGB	VESA480-75		
1853	35.16	56.25	36.000	800 × 600	Prog	P	P	ANALOG	RGB	VESA600-56		
1854	37.88	60.32	40.000	800 × 600	Prog	P	P	ANALOG	RGB	VESA600-60		
1855	48.08	72.19	50.000	800 × 600	Prog	P	P	ANALOG	RGB	VESA600-72		
1856	48.36	60.00	65.000	1024 × 768	Prog	N	N	ANALOG	RGB	VESA768-60		
1857	56.48	70.07	75.000	1024 × 768	Prog	N	N	ANALOG	RGB	VESA768-70		
1858	60.02	75.03	78.750	1024 × 768	Prog	P	P	ANALOG	RGB	VESA768-75		
1859	79.98	75.02	135.000	1280 × 1024	Prog	P	P	ANALOG	RGB	VESA1024-75		
1860	91.15	85.02	157.500	1280 × 1024	Prog	P	P	ANALOG	RGB	VESA1024-85		
1861	75.00	60.00	162.000	1600 × 1200	Prog	P	P	ANALOG	RGB	VESA1200-60		
1862	81.25	65.00	175.500	1600 × 1200	Prog	P	P	ANALOG	RGB	VESA1200-65		
1863	87.50	70.00	189.000	1600 × 1200	Prog	P	P	ANALOG	RGB	VESA1200-70		
1864	93.75	75.00	202.500	1600 × 1200	Prog	P	P	ANALOG	RGB	VESA1200-75		
1865	100.00	80.00	216.000	1600 × 1200	Prog	P	P	ANALOG	RGB	VESA1200-80		
1866	106.25	85.00	229.500	1600 × 1200	Prog	P	P	ANALOG	RGB	VESA1200-85		
1867	98.21	70.05	236.500	1800 × 1350	Prog	N	P	ANALOG	RGB	VESA1350-70		
1868	18.44	49.83	16.260	720 × 350	Prog	N	N	ANALOG	RGB	MDA		
1869	15.75	60.10	14.360	640 × 200	Prog	N	N	ANALOG	RGB	CGA		
1870	21.85	59.71	16.260	640 × 350	Prog	N	N	ANALOG	RGB	EGA		

Internal program data: No. 1850 to 1870



Program No.	Horizontal frequency [KHz]	Vertical frequency [Hz]	Dot clock frequency [MHz]	No. of display dots (H × V)	Int / Prog	Sync polarity		SyncType	Color difference	Timing data name	Pattern data	Pattern data name
						H	V					
1871	30.48	60.00	24.870	640 × 400	Prog	N	N	ANALOG	RGB	PGA		
1872	31.47	50.03	28.320	720 × 350	Prog	N	N	ANALOG	RGB	VGA-TEXT350-50		
1873	31.47	59.94	28.320	720 × 350	Prog	N	N	ANALOG	RGB	VGA-TEXT350-60		
1874	31.47	70.08	28.320	720 × 350	Prog	N	N	ANALOG	RGB	VGA-TEXT350-70		
1875	31.47	50.03	28.320	720 × 400	Prog	N	N	ANALOG	RGB	VGA-TEXT400-50		
1876	31.47	59.94	28.320	720 × 400	Prog	N	N	ANALOG	RGB	VGA-TEXT400-60		
1877	31.47	70.08	28.320	720 × 400	Prog	N	N	ANALOG	RGB	VGA-TEXT400-70		
1878	31.47	50.03	25.175	640 × 350	Prog	N	N	ANALOG	RGB	VGA350-50		
1879	31.47	59.94	25.175	640 × 350	Prog	N	N	ANALOG	RGB	VGA350-60		
1880	31.47	70.09	25.175	640 × 350	Prog	N	N	ANALOG	RGB	VGA350-70		
1881	31.47	50.03	25.175	640 × 400	Prog	N	N	ANALOG	RGB	VGA400-50		
1882	31.47	59.94	25.175	640 × 400	Prog	N	N	ANALOG	RGB	VGA400-60		
1883	31.47	70.09	25.175	640 × 400	Prog	N	N	ANALOG	RGB	VGA400-70		
1884	31.47	50.03	25.175	640 × 480	Prog	N	N	ANALOG	RGB	VGA480-50		
1885	31.47	59.94	25.175	640 × 480	Prog	N	N	ANALOG	RGB	VGA480-60		
1886	35.16	56.16	36.000	800 × 600	Prog	N	N	ANALOG	RGB	S-VGA-56		
1887	48.08	72.19	50.000	800 × 600	Prog	N	N	ANALOG	RGB	S-VGA-72		
1888	46.88	75.00	49.500	800 × 600	Prog	N	N	ANALOG	RGB	S-VGA-75		
1889	48.08	59.80	65.000	1024 × 768	Prog	N	N	ANALOG	RGB	XGA-60		
1890	53.95	66.11	71.640	1024 × 768	Prog	N	N	ANALOG	RGB	XGA-66		

Internal program data: No. 1871 to 1890

Program No.	Horizontal frequency [KHz]	Vertical frequency [Hz]	Dot clock frequency [MHz]	No. of display dots (H × V)	Int / Prog	Sync polarity		SyncType	Color difference	Timing data name	Pattern data	Pattern data name
						H	V					
1891	56.48	70.07	75.000	1024 × 768	Prog	N	N	ANALOG	RGB	XGA-70		
1892	60.68	57.03	100.000	1280 × 1024	Prog	N	N	ANALOG	RGB	SXGA-57		
1893	63.5	59.68	106.930	1280 × 1024	Prog	N	N	ANALOG	RGB	SXGA-60A		
1894	63.75	59.75	110.160	1280 × 1024	Prog	N	N	ANALOG	RGB	SXGA-60B		
1895	63.72	60.00	109.470	1280 × 1024	Prog	N	N	ANALOG	RGB	SXGA-60C		
1896	78.91	74.16	132.880	1280 × 1024	Prog	N	N	ANALOG	RGB	SXGA-70		
1897	74.63	59.94	160.000	1600 × 1200	Prog	N	N	ANALOG	RGB	UXGA1200-60		
1898	107.42	85.05	220.000	1600 × 1200	Prog	N	N	ANALOG	RGB	UXGA1200-85A		
1899	106.48	85.05	230.000	1600 × 1200	Prog	N	N	ANALOG	RGB	UXGA1200-85B		
1900	107.42	80.05	220.000	1600 × 1280	Prog	N	N	ANALOG	RGB	UXGA1280-80A		
1901	106.48	80.06	230.000	1600 × 1280	Prog	N	N	ANALOG	RGB	UXGA1280-80B		
1902	106.4	80.00	238.340	1600 × 1280	Prog	N	N	ANALOG	RGB	UXGA1280-80C		
1903	109.82	80.40	246.000	1600 × 1280	Prog	N	N	ANALOG	RGB	UXGA1280-82		
1904	35.52	86.96	44.900	1024 × 768	Int	N	N	ANALOG	RGB	IBM 8514A		
1905	63.36	60.00	89.210	1024 × 1024	Prog	N	N	ANALOG	RGB	IBM 5080		
1906	29.58	73.14	24.020	640 × 754	Int	N	N	ANALOG	RGB	IBM 5550		
1907	63.36	60.00	111.520	1280 × 1024	Prog	N	N	ANALOG	RGB	IBM 6000		
1908	15.71	59.98	6.380	323 × 246	Prog	N	N	ANALOG	RGB	NAVIGATION		
1909	35	66.67	30.240	640 × 480	Prog	N	N	ANALOG	RGB	Mac 480-66A		
1910	34.97	66.60	31.330	640 × 480	Prog	N	N	ANALOG	RGB	Mac 480-66B		

Internal program data: No. 1891 to 1910



Program No.	Horizontal frequency [KHz]	Vertical frequency [Hz]	Dot clock frequency [MHz]	No. of display dots (H × V)	Int / Prog	Sync polarity		SyncType	Color difference	Timing data name	Pattern data	Pattern data name
						H	V					
1911	48.83	66.89	50.000	800 × 600	Prog	N	N	ANALOG	RGB	Mac 600-66		
1912	49.72	74.55	57.280	832 × 624	Prog	N	N	ANALOG	RGB	Mac 624-57		
1913	48.78	59.56	64.000	1024 × 768	Prog	N	N	ANALOG	RGB	Mac 768-60		
1914	60.24	74.93	80.000	1024 × 768	Prog	N	N	ANALOG	RGB	Mac 768-75		
1915	68.68	75.06	100.000	1152 × 870	Prog	N	N	ANALOG	RGB	Mac 870-75		
1916	24.82	56.42	21.050	640 × 400	Prog	N	N	ANALOG	RGB	NEC PC9801		
1917	32.86	79.84	47.840	1120 × 750	Int	N	N	ANALOG	RGB	NEC PC9801XL		
1918	50.02	60.05	78.430	1120 × 750	Prog	N	N	ANALOG	RGB	NEC 768-60A		
1919	56.48	70.07	75.000	1024 × 768	Prog	N	N	ANALOG	RGB	NEC 768-70		
1920	64.6	59.93	107.500	1280 × 1024	Prog	N	N	ANALOG	RGB	NEC 1024-60		
1921	74.88	69.85	127.000	1280 × 1024	Prog	N	N	ANALOG	RGB	NEC 1024-70		
1922	78.86	74.11	135.000	1280 × 1024	Prog	N	N	ANALOG	RGB	NEC 1024-75		
1923	48.36	60.08	65.000	1024 × 768	Prog	N	N	ANALOG	RGB	NEC 768-60B		
1924	61.8	65.95	92.940	1152 × 900	Prog	N	N	ANALOG	RGB	SUN 900-66		
1925	71.73	76.07	105.590	1152 × 900	Prog	N	N	ANALOG	RGB	SUN 900-76		
1926	70.84	84.03	92.940	1024 × 800	Prog	N	N	ANALOG	RGB	SUN 800-84		
1927	81.13	76.11	135.000	1280 × 1024	Prog	N	N	ANALOG	RGB	SUN 1024-76		
1928	63.38	60.02	107.500	1280 × 1024	Prog	N	N	ANALOG	RGB	SONY NEWS		
1929	78.86	74.11	135.000	1280 × 1024	Prog	N	N	ANALOG	RGB	SONY 1024-74		
1930	78.86	74.11	135.000	1280 × 1024	Prog	N	N	ANALOG	RGB	SONY 1024-74		

Internal program data: No. 1911 to 1930

Program No.	Horizontal frequency [KHz]	Vertical frequency [Hz]	Dot clock frequency [MHz]	No. of display dots (H × V)	Int / Prog	Sync polarity		SyncType	Color difference	Timing data name	Pattern data	Pattern data name
						H	V					
1931	48.48	59.64	64.000	1024 × 768	Prog	N	N	ANALOG	RGB	SGI Indigo768-60		
1932	77.01	72.38	130.000	1280 × 1024	Prog	N	N	ANALOG	RGB	SGI Indigo1024-72		
1933	63.9	60.00	107.350	1280 × 1024	Prog	N	N	ANALOG	RGB	SGI IRIS4D		
1934	63.33	59.97	108.170	1280 × 1024	Prog	N	N	ANALOG	RGB	HP 9000t1		
1935	78.13	72.00	135.000	1280 × 1024	Prog	N	N	ANALOG	RGB	HP 9000t2		
1936	54	60.00	69.120	1024 × 864	Prog	N	N	ANALOG	RGB	VAX 768-60		
1937	70.66	66.47	119.840	1280 × 1024	Prog	N	N	ANALOG	RGB	VAX 1024-66		
1938	60.05	75.06	78.780	1024 × 768	Prog	N	N	ANALOG	RGB	Fujitsu FMV 1024-75		
1939	80.66	100.83	108.410	1024 × 768	Prog	N	N	ANALOG	RGB	Fujitsu FMV 1024-100		
1940	79.7	74.83	134.370	1280 × 1024	Prog	N	N	ANALOG	RGB	Fujitsu FMV5166		
1941	80.38	75.12	135.040	1280 × 1024	Prog	N	N	ANALOG	RGB	Fujitsu FMV5133		
1942	63.74	60.02	108.100	1280 × 1024	Prog	N	N	ANALOG	RGB	Fujitsu SIGMA		
1943	78.16	71.64	135.060	1280 × 1024	Prog	N	N	ANALOG	RGB	HITACHI SXGA		
1944	26.35	59.90	22.770	640 × 400	Prog	N	N	ANALOG	RGB	Panasonic M550		
1945	46.88	75.00	49.500	800 × 600	Prog	P	P	ANALOG	RGB	VESA600-75		
1946	31.47	59.94	25.175	640 × 480	Prog	N	N	ANALOG	RGB	VGA480-60		
1947	31.47	59.95	28.640	746 × 471	Prog	N	N	ANALOG	RGB	ASTRO SC-2025		
1948	64	59.98	115.200	1400 × 1050	Prog	N	N	ANALOG	RGB	SXGA+		
1949	94.64	59.60	265.000	2048 × 1536	Prog	N	N	ANALOG	RGB	QXGA		
1950	15.73	59.94	13.500	712 × 484	Int	N	N	NTSC	YPbPr	NTSC		

Internal program data: No. 1931 to 1950



Program No.	Horizontal frequency [KHz]	Vertical frequency [Hz]	Dot clock frequency [MHz]	No. of display dots (H × V)	Int / Prog	Sync polarity		SyncType	Color difference	Timing data name	Pattern data	Pattern data name
						H	V					
1951	33.75	60.00	74.250	1920 × 1080	Int	N	N	HDTV1080	YPbPr	1080i		
1952	31.47	59.94	25.175	640 × 480	Prog	N	N	ANALOG	RGB	VGA480-60		
1953	31.47	59.94	25.175	640 × 480	Prog	N	N	ANALOG	RGB	VGA480-60		
1954	31.47	59.94	25.175	640 × 480	Prog	N	N	ANALOG	RGB	VGA480-60		
1955	31.47	59.94	25.175	640 × 480	Prog	N	N	ANALOG	RGB	VGA480-60		
1956	31.22	49.98	46.200	1170 × 1168	Int	N	N	ANALOG	RGB	MEDICAL-1I		
1957	31.22	50.03	46.200	1170 × 584	Prog	N	N	ANALOG	RGB	MEDICAL-1N		
1958	30.69	60.00	36.830	947 × 946	Int	N	N	ANALOG	RGB	MEDICAL-2I		
1959	30.69	60.06	36.830	947 × 473	Prog	N	N	ANALOG	RGB	MEDICAL-2N		
1960	37.93	85.04	35.500	720 × 400	Prog	N	P	ANALOG	RGB	VESA400-88		
1961	112.5	90.00	243.000	1600 × 1200	Prog	N	N	ANALOG	RGB	1200-90		
1962	31.47	59.94	25.175	640 × 480	Prog	N	N	ANALOG	RGB	VGA480-60		
1963	63.98	60.02	108.000	1280 × 1024	Prog	P	P	ANALOG	RGB	VESA1024-60		
1964	15.63	50.00	13.500	702 × 574	Int	N	N	SECAM	YPbPr	SECAM		
1965	31.47	59.94	34.240	864 × 480	Prog	N	N	ANALOG	RGB	W-VGA		
1966	37.88	60.32	53.940	1072 × 600	Prog	N	N	ANALOG	RGB	W-SVGA		
1967	48.36	60.00	87.440	1376 × 768	Prog	N	N	ANALOG	RGB	W-XGA		
1968	15.73	59.94	13.500	712 × 484	Int	N	N	NTSC	YPbPr	NTSC		
1969	15.63	50.00	13.500	702 × 574	Int	N	N	PAL	YPbPr	PAL		
1970	67.5	60.00	148.500	1920 × 1080	Prog	N	N	HDTV1080	YPbPr	1080P		

Internal program data: No. 1951 to 1970

Program No.	Horizontal frequency [KHz]	Vertical frequency [Hz]	Dot clock frequency [MHz]	No. of display dots (H × V)	Int / Prog	Sync polarity		SyncType	Color difference	Timing data name	Pattern data	Pattern data name
						H	V					
1971	67.43	59.94	148.352	1920 × 1080	Prog	N	N	HDTV1080	YPbPr	1080P		
1972	33.75	60.00	74.250	1920 × 1080	Int	N	N	HDTV1080	YPbPr	1080i		
1973	33.72	59.94	74.176	1920 × 1080	Int	N	N	HDTV1080	YPbPr	1080i		
1974	33.75	60.00	74.250	1920 × 1035	Int	N	N	HDTV1080	YPbPr	1035i		
1975	33.72	59.94	74.176	1920 × 1035	Int	N	N	HDTV1080	YPbPr	1035i		
1976	45	60.00	74.250	1280 × 720	Prog	N	N	HDTV720	YPbPr	720P		
1977	44.96	59.94	74.176	1280 × 720	Prog	N	N	HDTV720	YPbPr	720P		
1978	31.47	59.94	27.000	720 × 483	Prog	N	N	ANALOG	YPbPr	483P		
1979	31.25	50.00	27.000	720 × 576	Prog	N	N	ANALOG	YPbPr	PAL*2		
1980	83.64	60.00	204.750	1792 × 1344	Prog	N	P	ANALOG	RGB	VESA1344-60		
1981	83.64	60.00	204.750	1792 × 1344	Prog	N	P	ANALOG	RGB	VESA1344-60		
1982	86.33	60.00	218.250	1856 × 1392	Prog	N	P	ANALOG	RGB	VESA1392-60		
1983	86.33	60.00	218.250	1856 × 1392	Prog	N	P	ANALOG	RGB	VESA1392-60		
1984	90	60.00	234.000	1920 × 1440	Prog	N	P	ANALOG	RGB	VESA1440-60		
1985	90	60.00	234.000	1920 × 1440	Prog	N	P	ANALOG	RGB	VESA1440-60		
1986	31.47	59.94	25.175	640 × 480	Prog	N	N	ANALOG	RGB	VGA480-60		
1987	31.47	59.94	25.175	640 × 480	Prog	N	N	ANALOG	RGB	VGA480-60		
1988	31.47	59.94	25.175	640 × 480	Prog	N	N	ANALOG	RGB	VGA480-60		
1989	31.47	59.94	25.175	640 × 480	Prog	N	N	ANALOG	RGB	VGA480-60		
1990	31.47	59.94	25.175	640 × 480	Prog	N	N	ANALOG	RGB	VGA480-60		

Internal program data: No. 1971 to 1990











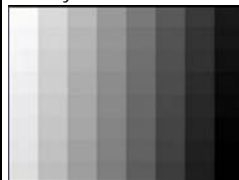
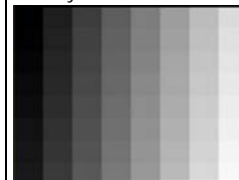
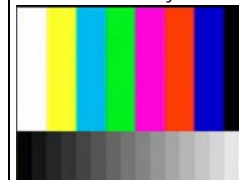
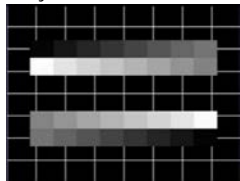
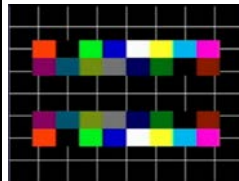

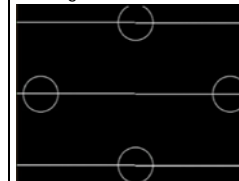
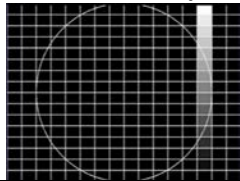
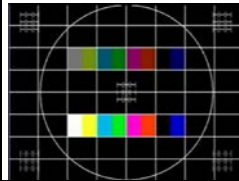
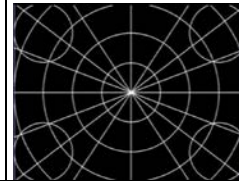
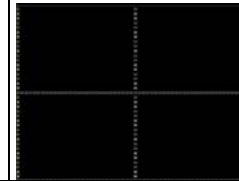

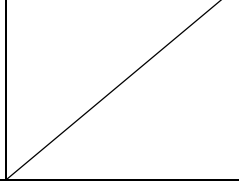

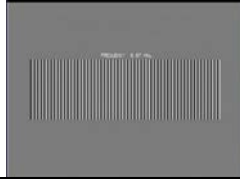

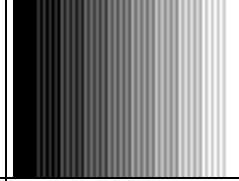

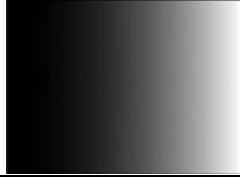
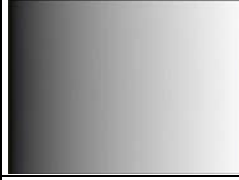
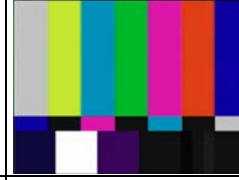
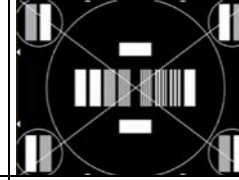
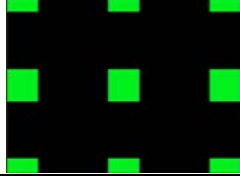
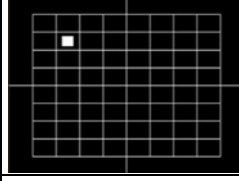

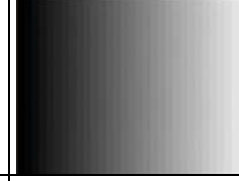

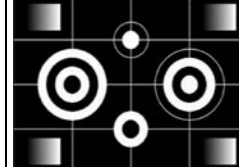





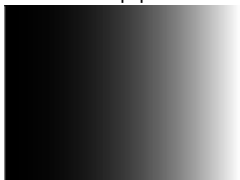
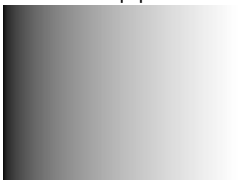
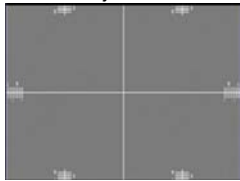
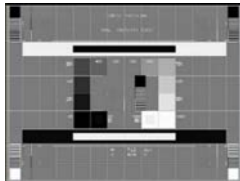
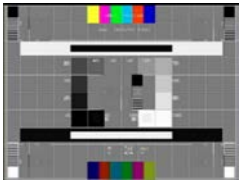

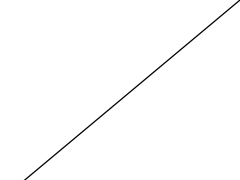
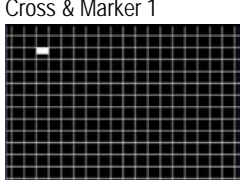
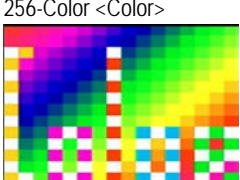
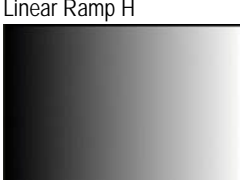

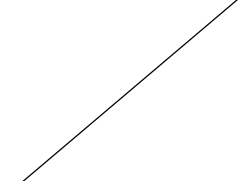

Program No.	Horizontal frequency [KHz]	Vertical frequency [Hz]	Dot clock frequency [MHz]	No. of display dots (H x V)	Int / Prog	Sync polarity		SyncType	Color difference	Timing data name	Pattern data	Pattern data name
						H	V					
1991	31.47	59.94	25.175	640 x 480	Prog	N	N	ANALOG	RGB	VGA480-60		
1992	31.47	59.94	25.175	640 x 480	Prog	N	N	ANALOG	RGB	VGA480-60		
1993	31.47	59.94	25.175	640 x 480	Prog	N	N	ANALOG	RGB	VGA480-60		
1994	15.73	59.94	13.500	712 x 484	Int	N	N	NTSC-M	YPbPr	NTSC-M		
1995	31.47	59.94	25.175	640 x 480	Prog	N	N	ANALOG	RGB	VGA480-60		
1996	31.47	59.94	25.175	640 x 480	Prog	N	N	ANALOG	RGB	VGA480-60		
1997	48.08	72.19	50.000	800 x 600	Prog	P	P	ANALOG	RGB	VESA600-72		
1998	56.48	70.07	75.000	1024 x 768	Prog	N	N	ANALOG	RGB	VESA768-70		
1999	79.98	75.02	135.000	1280 x 1024	Prog	P	P	ANALOG	RGB	VESA1024-75		

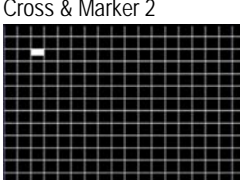
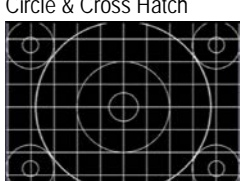



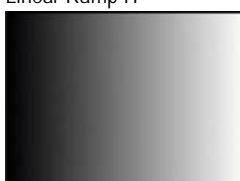

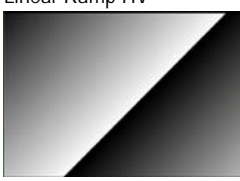
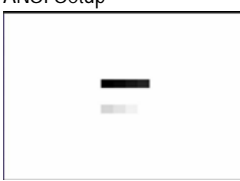
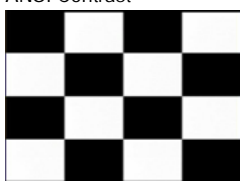
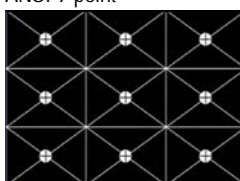
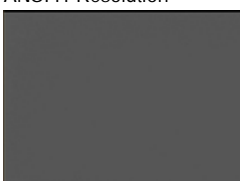



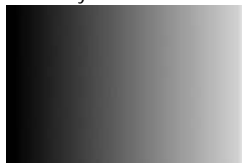
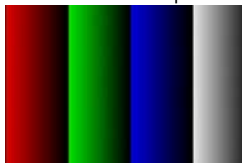
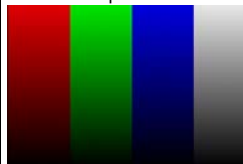

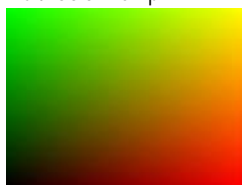
Internal program data: No. 1991 to 1999

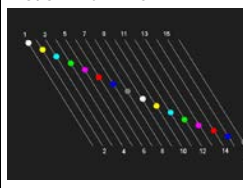
11.3.2 Optional pattern data

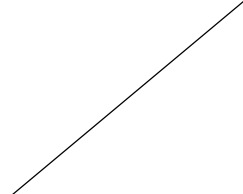
The internal optional pattern data (No.1 to No.70) of the VG-870B/871B is as shown below.

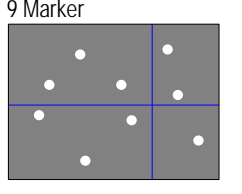
No.	Pattern Name	No.	Pattern Name	No.	Pattern Name	No.	Pattern Name
1	256-Color Block 	2	64Gray Block White-> 	3	64Gray Block Black-> 	4	8-Color & 16-Gray 
5	Gray & Cross Hatch 	6	Color & Cross Hatch 	7	Color Temperature 	8	Pairing 
9	Cross & Circle & Gray 	10	Cross & Circle & Color & H 	11	Circle & Line 	12	H-Character Line 
13	O-Character Line 	14	Cross Talk W = 90% 	15		16	NTSC Color 
17	Sign Wave Scroll 	18	Multi Burst 100% 	19	1/10 MHz x 10step 	20	Gamma Ramp $\gamma=2.5$ 
21	Gamma Ramp $\gamma=2.0$ 	22	Gamma Ramp $\gamma=0.5$ 	23	SMPTE Color 	24	SMPTE RP-27.1 
25	ITC 9-Window 	26	ITC Cross & Marker 	27	ITC H-Character 	28	32-Gray H 
29	64-Gray H 	30	64-Gray H & RGBW-Color 	31	Gray & Circle 	32	AFD 

33	Corner & Center Marker 	34	Cross Talk W = 60% 	35	Gamma Ramp $\gamma = 2.2$ 	36	Gamma Ramp $\gamma = 0.45$ 
37	Position Adjuster 	38	SMPTE RP-133 	39	SMPTE RP-133 Color 	40	SpeakerCheck / Youth 
41		42	Cross & Marker 1 	43	256-Color <Color> 	44	Linear Ramp H 
45	Linear Ramp V 	46	256-Color Random 	47		48	256-Gray & 7-Color 
49	Corner & Center Window 	50	32-Gray H2 	51	3gray-Window 	52	Cross & Marker 2 
53	Circle & Cross Hatch 	54	1dotChecker & Window 	55	32-Gray V 	56	64-Gray V 
57	Linear Ramp H 	58	Linear Ramp V 	59	Linear Ramp HV 	60	ANSI Setup 
61	ANSI Contrast 	62	ANSI 9-point 	63	ANSI H-Resolution 	64	ANSI V-Resolution 

65	128-Gray H 	66	RGBW Linear Ramp H 	67	Linear Ramp & RGBW V 	68	Linear Ramp & RGBW H 
69	Multi-Color Ramp HV 	70	Linear/256 Ramp H 	71	Motion Blur Line 	72	Spectrum 
73		74	Ramp Limited-H 	75	Ramp Limited-V 	76	9 Marker 
77	SMPTE Color CVBS *2 	78	SMPTE Color COMP *3 	101	3D Pattern *1 		

*1: This pattern requires the license. To purchase it, contact ASTRODESIGN sales.

*2: This is a minus level-compatible pattern used exclusively for analog CVBS outputs. It cannot be displayed at the correct level from other outputs.

*3: This is a minus level-compatible pattern used exclusively for analog component outputs. It cannot be displayed at the correct level from other outputs.

11.3.3 User character pattern data

Code (H)	Description	Cell size	Reference page
F0	Letters "me" #1	18 x 18	p.519
F1	Letters "me" #2 (VESA specifications)	18 x 18	p.519
F2	Chinese character "AI"	64 x 64	p.520
F3	Chinese character "BI"	64 x 64	p.520
F4	Chinese character "TAKA"	32 x 32	p.521
F5	Chinese character "KIRI"	32 x 32	p.521
F6	Chinese character "KEN"	32 x 32	p.522
F7	Burst	64 x 64	p.522
F8			
F9			
FA			
FB			
FC			
FD			
FE			
FF			

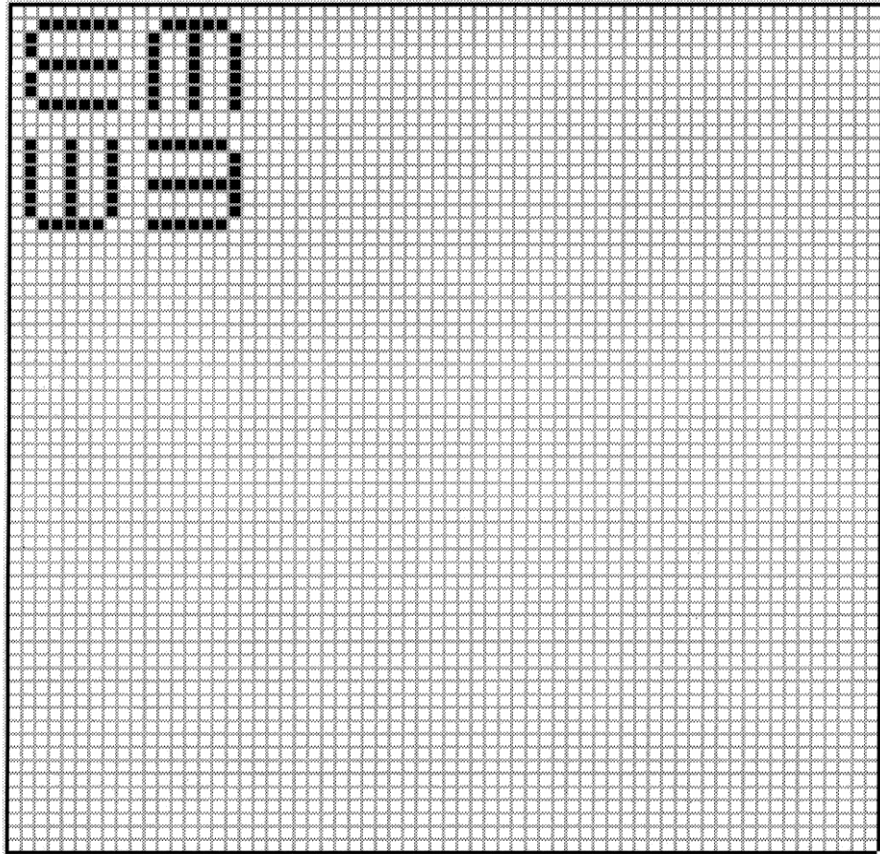
■ F0H [letters “me” #1]/F1H [letters “me” #2 (VESA specifications)]**F0H****F1H**

■ F2H [Chinese character “AI”]/F3H [Chinese character “BI”]

F2H

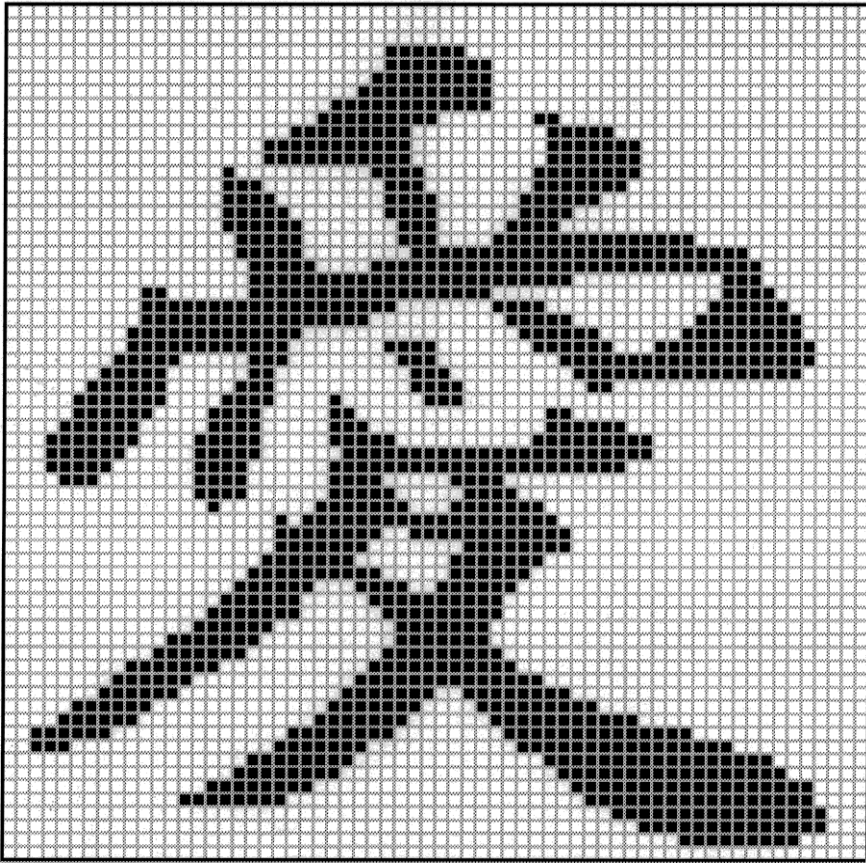

F3H

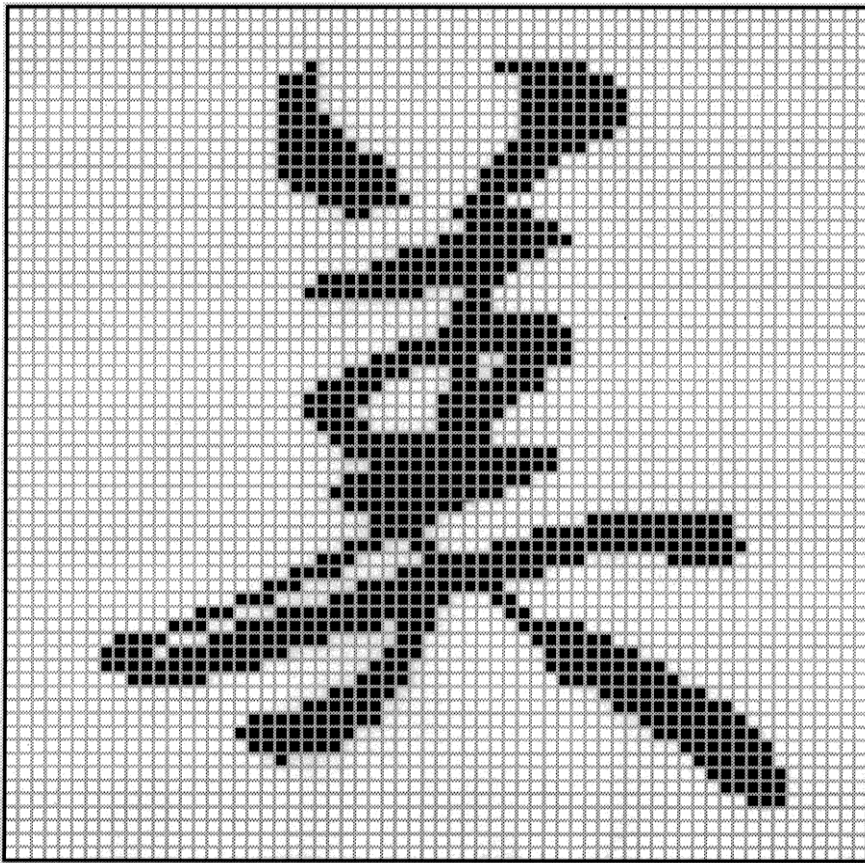

■ F4H [Chinese character “TAKA”]/F5H [Chinese character “KIRI”]

F4H

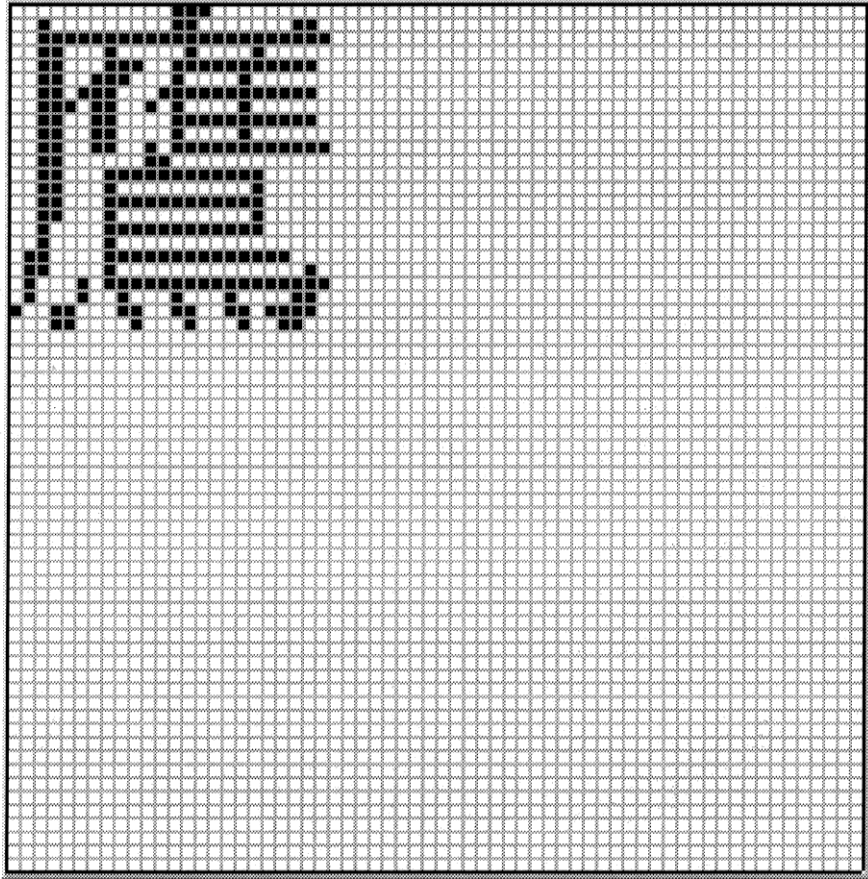

F5H

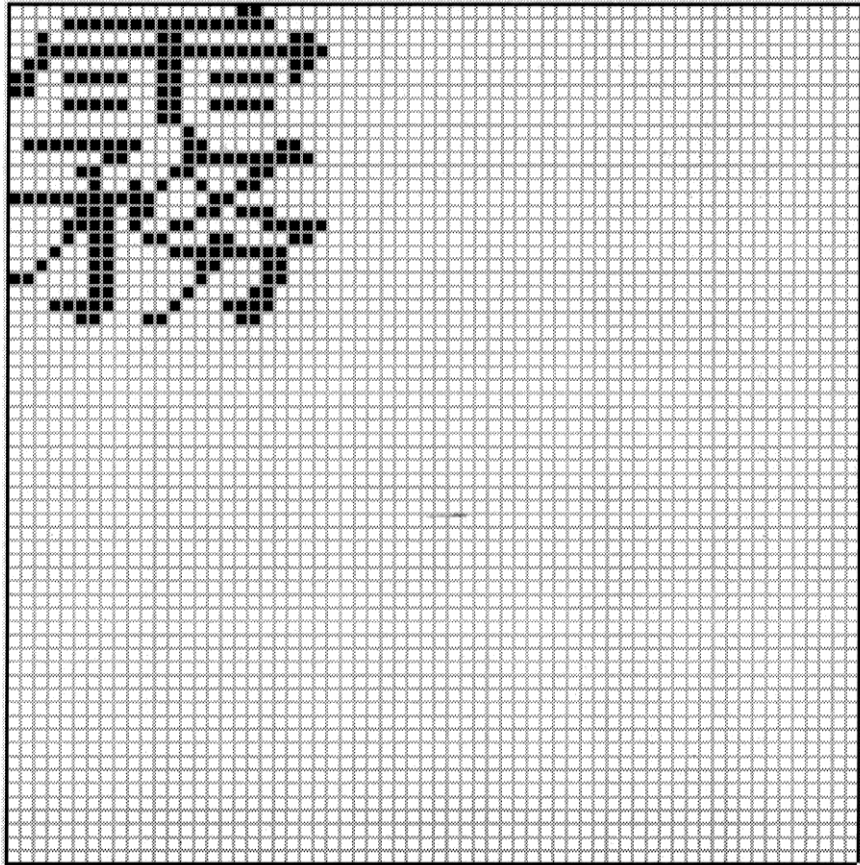

■ F6H [Chinese character “KEN”]/F7H [Burst]

F6H

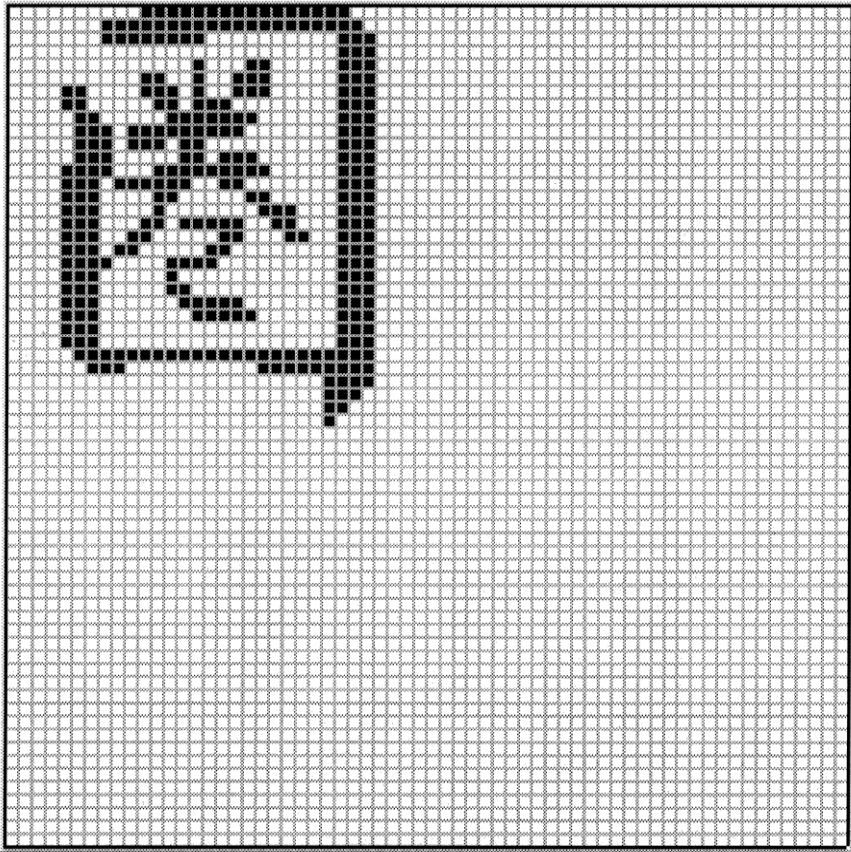

F7H

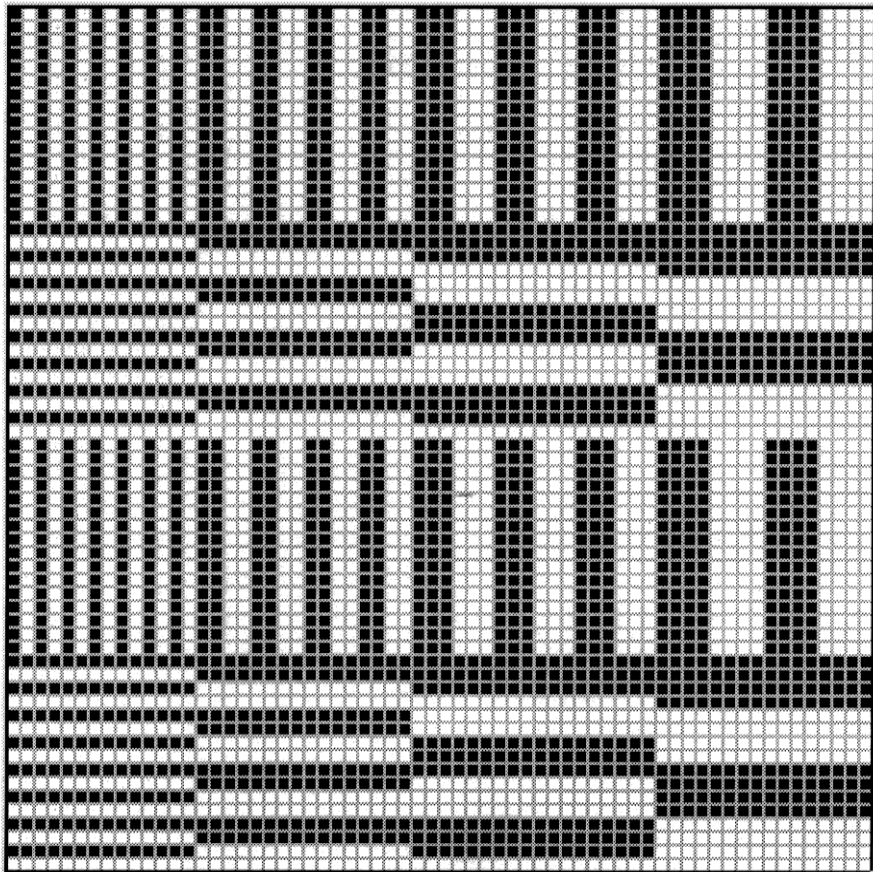

11.3.4 Character pattern data

■ 5 × 7 character pattern table (1 of 2)

20H 	21H 	22H 	23H 	24H 	25H 	26H 	27H
28H 	29H 	2AH 	2BH 	2CH 	2DH 	2EH 	2FH
30H 	31H 	32H 	33H 	34H 	35H 	36H 	37H
38H 	39H 	3AH 	3BH 	3CH 	3DH 	3EH 	3FH
40H 	41H 	42H 	43H 	44H 	45H 	46H 	47H
48H 	49H 	4AH 	4BH 	4CH 	4DH 	4EH 	4FH
50H 	51H 	52H 	53H 	54H 	55H 	56H 	57H
58H 	59H 	5AH 	5BH 	5CH 	5DH 	5EH 	5FH
60H 	61H 	62H 	63H 	64H 	65H 	66H 	67H
68H 	69H 	6AH 	6BH 	6CH 	6DH 	6EH 	6FH
70H 	71H 	72H 	73H 	74H 	75H 	76H 	77H
78H 	79H 	7AH 	7BH 	7CH 	7DH 	7EH 	7FH

■ 5 × 7 character pattern table (2 of 2)

80H	81H	82H	83H	84H	85H	86H	87H
88H	89H	8AH	8BH	8CH	8DH	8EH	8FH
90H	91H	92H	93H	94H	95H	96H	97H
98H	99H	9AH	9BH	9CH	9DH	9EH	9FH
A0H	A1H	A2H	A3H	A4H	A5H	A6H	A7H
A8H	A9H	AAH	ABH	ACH	ADH	AEH	AFH
B0H	B1H	B2H	B3H	B4H	B5H	B6H	B7H
B8H	B9H	BAH	BBH	BCH	BDH	BEH	BFH
C0H	C1H	C2H	C3H	C4H	C5H	C6H	C7H
C8H	C9H	CAH	CBH	CCH	CDH	CEH	CFH
D0H	D1H	D2H	D3H	D4H	D5H	D6H	D7H
D8H	D9H	DAH	DBH	DCH	DDH	DEH	DFH

■ 7 × 9 character pattern table (1 of 2)



20H	21H	22H	23H	24H	25H	26H	27H
28H	29H	2AH	2BH	2CH	2DH	2EH	2FH
30H	31H	32H	33H	34H	35H	36H	37H
38H	39H	3AH	3BH	3CH	3DH	3EH	3FH
40H	41H	42H	43H	44H	45H	46H	47H
48H	49H	4AH	4BH	4CH	4DH	4EH	4FH
50H	51H	52H	53H	54H	55H	56H	57H
58H	59H	5AH	5BH	5CH	5DH	5EH	5FH
60H	61H	62H	63H	64H	65H	66H	67H
68H	69H	6AH	6BH	6CH	6DH	6EH	6FH
70H	71H	72H	73H	74H	75H	76H	77H
78H	79H	7AH	7BH	7CH	7DH	7EH	7FH

■ 7 × 9 character pattern table (2 of 2)

* 8 × 9 dots are used for 80H to 8FH.

80H	81H	82H	83H	84H	85H	86H	87H
88H	89H	8AH	8BH	8CH	8DH	8EH	8FH
90H	91H	92H	93H	94H	95H	96H	97H
98H	99H	9AH	9BH	9CH	9DH	9EH	9FH
A0H	A1H	A2H	A3H	A4H	A5H	A6H	A7H
A8H	A9H	AAH	ABH	ACH	ADH	AEH	AFH
B0H	B1H	B2H	B3H	B4H	B5H	B6H	B7H
B8H	B9H	BAH	BBH	BCH	BDH	BEH	BFH
C0H	C1H	C2H	C3H	C4H	C5H	C6H	C7H
C8H	C9H	CAH	CBH	CCH	CDH	CEH	CFH
D0H	D1H	D2H	D3H	D4H	D5H	D6H	D7H
D8H	D9H	DAH	DBH	DCH	DDH	DEH	DFH

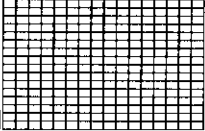
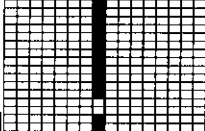
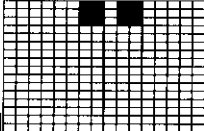
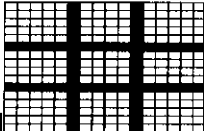
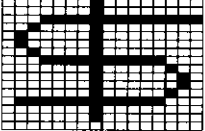
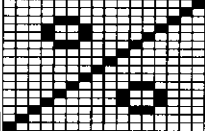
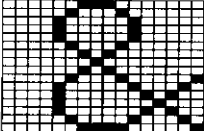
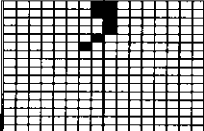
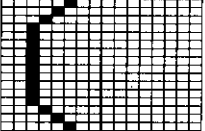
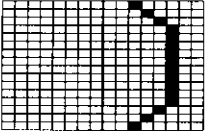
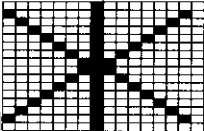
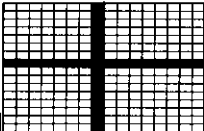
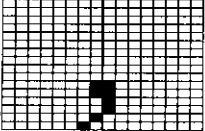
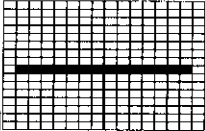
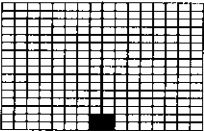
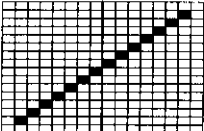
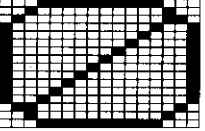
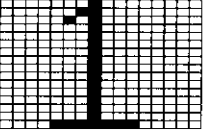
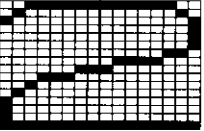
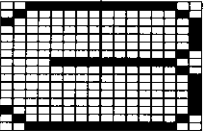
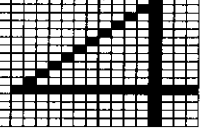
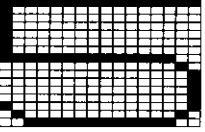
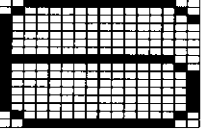
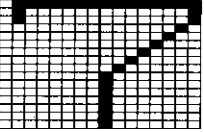
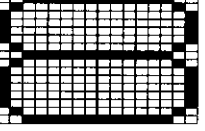
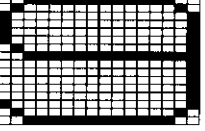
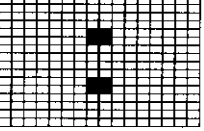
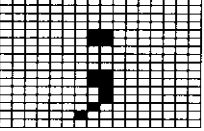
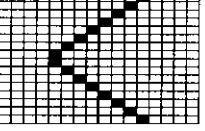
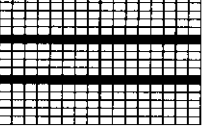
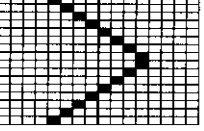
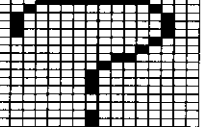
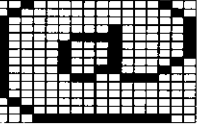
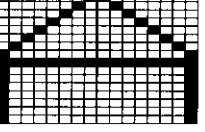
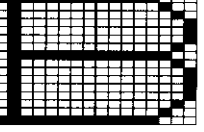
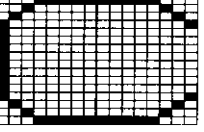
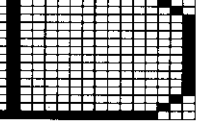
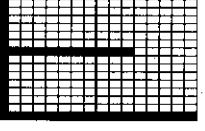
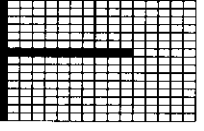
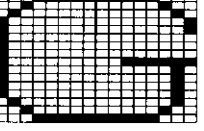
■ 16 × 16 character pattern table (1 of 4)

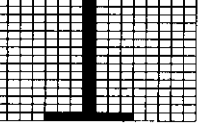
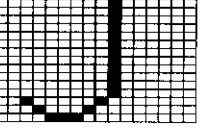
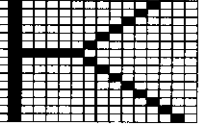
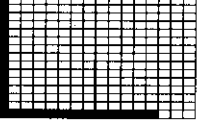
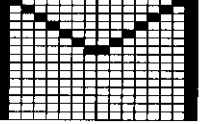
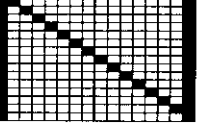
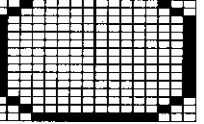
20H		21H		22H		23H	
24H		25H		26H		27H	
28H		29H		2AH		2BH	
2CH		2DH		2EH		2FH	
30H		31H		32H		33H	
34H		35H		36H		37H	
38H		39H		3AH		3BH	
3CH		3DH		3EH		3FH	
40H		41H		42H		43H	
44H		45H		46H		47H	
48H		49H		4AH		4BH	
4CH		4DH		4EH		4FH	

■ 16 × 16 character pattern table (2 of 4)

50H		51H		52H		53H	
54H		55H		56H		57H	
58H		59H		5AH		5BH	
5CH		5DH		5EH		5FH	
60H		61H		62H		63H	
64H		65H		66H		67H	
68H		69H		6AH		6BH	
6CH		6DH		6EH		6FH	
70H		71H		72H		73H	
74H		75H		76H		77H	
78H		79H		7AH		7BH	
7CH		7DH		7EH		7FH	

■ 16 × 16 character pattern table (3 of 4)

80H		81H		82H		83H	
84H		85H		86H		87H	
88H		89H		8AH		8BH	
8CH		8DH		8EH		8FH	
90H		91H		92H		93H	
94H		95H		96H		97H	
98H		99H		9AH		9BH	
9CH		9DH		9EH		9FH	
A0H		A1H		A2H		A3H	
A4H		A5H		A6H		A7H	
A8H		A9H		AAH		ABH	
ACH		ADH		AEH		AFH	

■ 16 × 16 character pattern table (4 of 4)

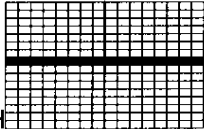
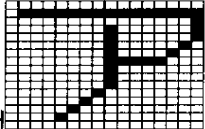
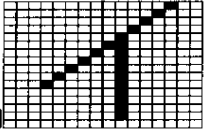
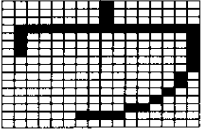
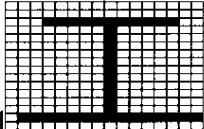
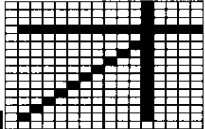
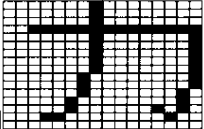
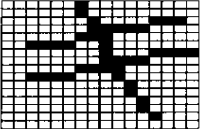
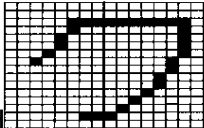
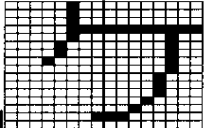
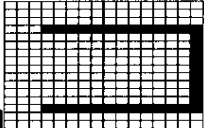
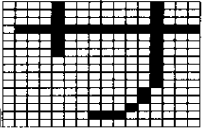
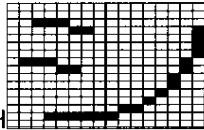
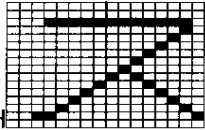
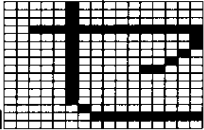
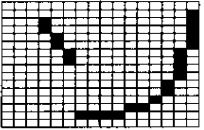
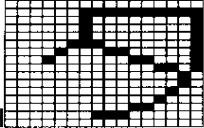
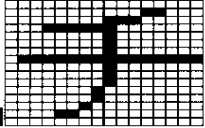
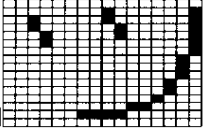
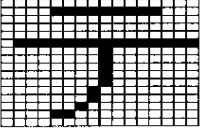
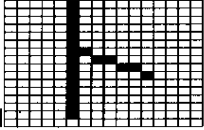
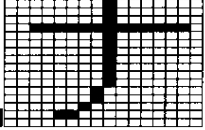
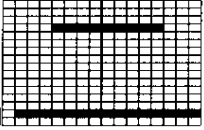
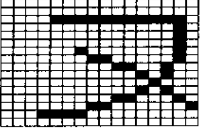
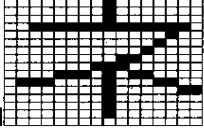
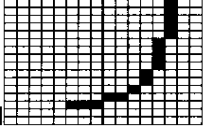
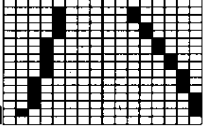
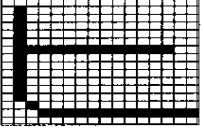
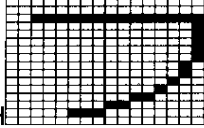
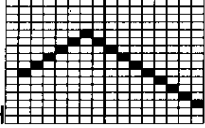
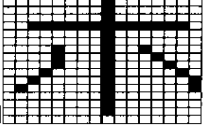
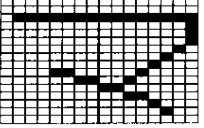
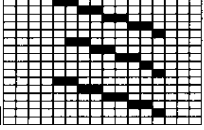
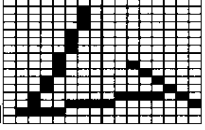
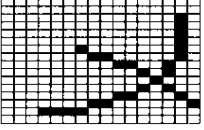
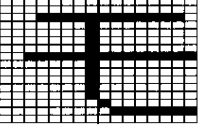
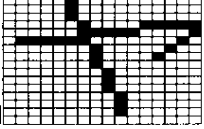
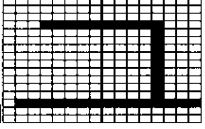
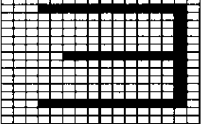
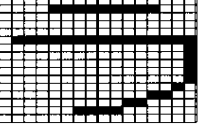
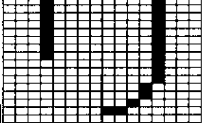
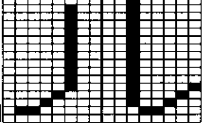
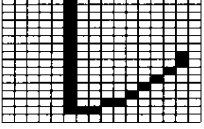
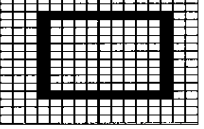
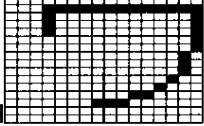
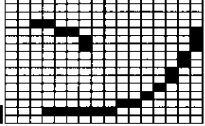
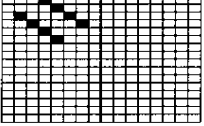
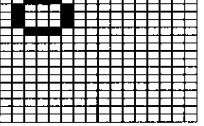
B0H		B1H		B2H		B3H	
B4H		B5H		B6H		B7H	
B8H		B9H		BAH		BBH	
BCH		BDH		BEH		BFH	
C0H		C1H		C2H		C3H	
C4H		C5H		C6H		C7H	
C8H		C9H		CAH		CBH	
CCH		CDH		CEH		CFH	
D0H		D1H		D2H		D3H	
D4H		D5H		D6H		D7H	
D8H		D9H		DAH		DBH	
DCH		DDH		DEH		DFH	

11.3.5 Tables of standard signals

■ Table of TV standard signals (1 of 2)

Signal format	Total no. of samples	Total no. of samples	Total no. of samples	Frame rate [Hz]	Scanning system	Subcarrier frequency [MHz]	Aspect ratio	Video level [mV]	Sync level [mV]	SETUP	Main countries where used
NTSC-J (Japan)	NTSC (RS-170A)	712 × 484	858 × 525	60/1.001	Interlaced	3.579545	4:3	714	286	No	Japan
NTSC-M	NTSC	712 × 484	858 × 525	60/1.001	Interlaced	3.579545	4:3	714	286	Yes	USA
NTSC-443	NTSC	712 × 484	858 × 525	60/1.001	Interlaced	4.43361875	4:3	714	286	Yes	
PAL-60	PAL	712 × 484	858 × 525	60/1.001	Interlaced	4.43361875	4:3	700	300	No	
PAL-M	PAL	712 × 484	858 × 525	60/1.001	Interlaced	3.57561189	4:3	714	286	Yes	Brazil
PAL (B/D/G/H/I/K)	PAL (BT.470-6)	702 × 574	864 × 625	50	Interlaced	4.43361875	4:3	700	300	No	U.K, Germany
PAL-N	PAL	718 × 574	864 × 625	50	Interlaced	4.43361875	4:3	714	286	Yes	Uruguay
PAL-Nc	PAL	702 × 574	864 × 625	50	Interlaced	3.58205625	4:3	700	300	No	Argentina
SECAM	SECAM	702 × 574	864 × 625	50	Interlaced	for = 4.406250 fob = 4.250000	4:3	700	300	No	France, Russia
483p (NTSC-PROG)	SMPTE293M	720 × 483	848 × 525	60/1.001	Progressive	-	4:3	700	300	-	-
576p (PAL-PROG)	BT.1358	720 × 574	864 × 625	50	Progressive	-	4:3	700	300	-	-

■ Table of TV standard signals (2 of 2)

Signal format	Total no. of samples	Total no. of samples	Total no. of samples	Frame rate [Hz]	Scanning system	Subcarrier frequency [MHz]	Aspect ratio	Video level [mV]	Sync level [mV]	SETUP	Main countries where used
720p	SMPTE296M	1280 × 720	1650 × 750	60	Progressive	-	16:9	700	300	-	-
			1650 × 750	60/1.001							
			1980 × 750	50							
			3300 × 750	30							
			3300 × 750	30/1.001							
			3960 × 750	25							
			4125 × 750	24							
			4125 × 750	24/1.001							
1035i	BTA S-001A	1920 × 1035	2200 × 1125	60	Interlaced	-	16:9	700	300	-	-
			60/1.001								
1080i	SMPTE274M	1920 × 1080	2200 × 1125	60	Interlaced	-	16:9	700	300		
			2200 × 1125	60/1.001							
			2640 × 1125	50							
1080p	SMPTE274M	1920 × 1080	2200 × 1125	60	Progressive	-	16:9	700	300		
			2200 × 1125	60/1.001							
			2640 × 1125	50							
			2200 × 1125	30							
			2200 × 1125	30/1.001							
			2640 × 1125	25							
			2750 × 1125	24							
			2750 × 1125	24/1.001							

■ Table of TV standard signal timing waveforms (1 of 3)

Signal	Sync signal waveform	Active line	Vertical blanking
NTSC-J PG1:950,968 PG2:918,919,930 PG3:980 NTSC-M PG1:994 PG2:924 NTSC-443 PG2:925 PAL-M PG2:926 PAL-60 PG2:927	ODD FIELD EVEN FIELD 	$1/T=13.5\text{MHz}$ HSYNC	T: 1-dot width
PAL-B/D/G/H/I/K PG1:949 PG2:920,921,931 PG3:981 PAL-Nc PG2:929 SECAM PG1:944 PG2:922,923,932 PG3:982	ODD FIELD EVEN FIELD 	$1/T=13.5\text{MHz}$ HSYNC	
PAL-N PG2:928	ODD FIELD EVEN FIELD 	$1/T=13.5\text{MHz}$ HSYNC	

■ Table of TV standard signal timing waveforms (2 of 3)

Signal	Sync signal waveform	Active line	Vertical blanking											
1080i PG1: 951, 972, 973 PG2: 933, 938, 939 PG3: 985, 986 1035i PG1: 974, 975 PG2: 934	ODDFIELD Note: There are no video signals in line 40 for 1920 x 1035i. EVENFIELD Note: The figures in parentheses are the 1280 x 720p line numbers.	$1/T = 74.25\text{MHz}$ or 74.138MHz <table border="1"> <thead> <tr> <th>Frame Rate</th> <th>AT</th> </tr> </thead> <tbody> <tr> <td>60/59.94</td> <td>44T</td> </tr> <tr> <td>50</td> <td>484T</td> </tr> </tbody> </table>	Frame Rate	AT	60/59.94	44T	50	484T	 $T: 1\text{dot width}$ $T: 1\text{-dot width}$					
Frame Rate	AT													
60/59.94	44T													
50	484T													
1080p PG1: 970, 971 PG2: 935, 936, 937 PG3: 983, 984 720p PG1: 976, 977 PG2: 940, 941, 942 PG3: 987, 988	 Note: The figures in parentheses are the 1280 x 720p line numbers.	$1/T = 74.25\text{MHz}$ or 74.138MHz <table border="1"> <thead> <tr> <th rowspan="2">Frame Rate</th> <th colspan="2">AT</th> </tr> <tr> <th>1080p</th> <th>720p</th> </tr> </thead> <tbody> <tr> <td>60/59.94</td> <td>44T</td> <td>70T</td> </tr> <tr> <td>50</td> <td>484T</td> <td>400T</td> </tr> </tbody> </table>	Frame Rate	AT		1080p	720p	60/59.94	44T	70T	50	484T	400T	 $T: 1\text{dot width}$
Frame Rate	AT													
	1080p	720p												
60/59.94	44T	70T												
50	484T	400T												
720x483p (NTSC-P) PG1: 978 PG2: 946, 947		$1/T = 27\text{MHz}$ 												
720x576p (PAL-P) PG1: 979 PG2: 948, 949	 Note: The figures in parentheses are the 1920 x 1035i line numbers.	$1/T = 27\text{MHz}$ 												

■ Table of TV standard signal timing waveforms (3 of 3)

Signal	Sync signal waveform	Active line	Vertical blanking
1080i SMPTE-295M (China) PG2: 998	ODD FIELD VSYNC EVEN FIELD VSYNC 	$1/T = 74.25\text{MHz}$ 	Vertical blanking T: 1-dot width
1080p SMPTE-295M PG2: 999 Only analog outputs supported	VSYNC 	$1/T = 74.25\text{MHz}$ 	
1152i (Australian) PG2: 944	ODD FIELD VSYNC EVEN FIELD VSYNC 	$1/T = 13.5\text{MHz}$ 	
1080i(1250) (Australian) PG2: 945	ODD FIELD VSYNC EVEN FIELD VSYNC 	$1/T = 13.5\text{MHz}$ 	



12

PRECAUTIONARY ITEMS

12.1 Differences between the generator models

This instructions manual has been designed for the VG-870B/871B and, as such, some functions are not supported by the VG-870/871/870A/871A. The table below lists the main differences between the models.

Main differences between the generator models

Function	VG-870/871	VG-870A/871A	VG-870B/871B	VG-873/874 (or VM-1823)
Moving images	Not supported	Supported	Supported	Supported
USB	Not supported	Supported	Supported	Supported
iTMD5	Not supported	Supported	Supported	Supported
V-by-One HS (VM-1825)	Not supported	Not supported	Supported	Supported
4K2K(iTMD5)(VM-1824)	Not supported	Not supported	Supported	Supported
4K2K (iTMD5 QUAD) (VM-1824-A)	Not supported	Not supported	Supported	Supported
HDMI300MHz	Not supported	Not supported	Not supported	Supported

* If you want to upgrade VG-870/871/870A/871A to VG-870B/871B, contact ASTRODESIGN sales representative.

12.2 Relationships between pattern drawing bit length and dot clock frequency

The pattern drawing bit length stands in relationships of dependency on the dot clock frequency. Pattern drawing bit lengths and dot clock frequencies outside the bounds of these relationships cannot be set. These relationships also differ depending on the output video bit length of each unit. They are shown in the following figures.

12.2.1 HDMI Unit (VM-1817, 1822, 1823)

The dot clock frequency is restricted by the pattern drawing bit length (Color Depth) shown in the figure below. Data skipping occurs when the output video bit length (Video Width) at this time is less than the pattern drawing bit length (Color Depth).

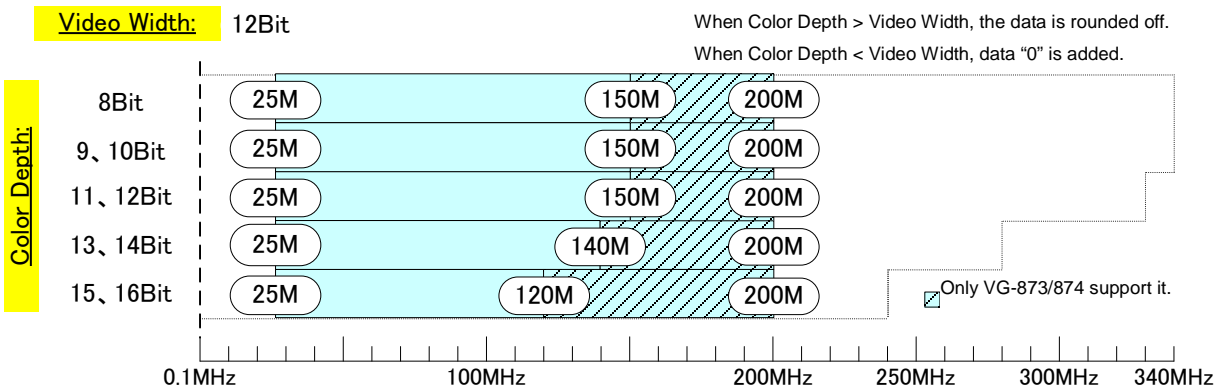
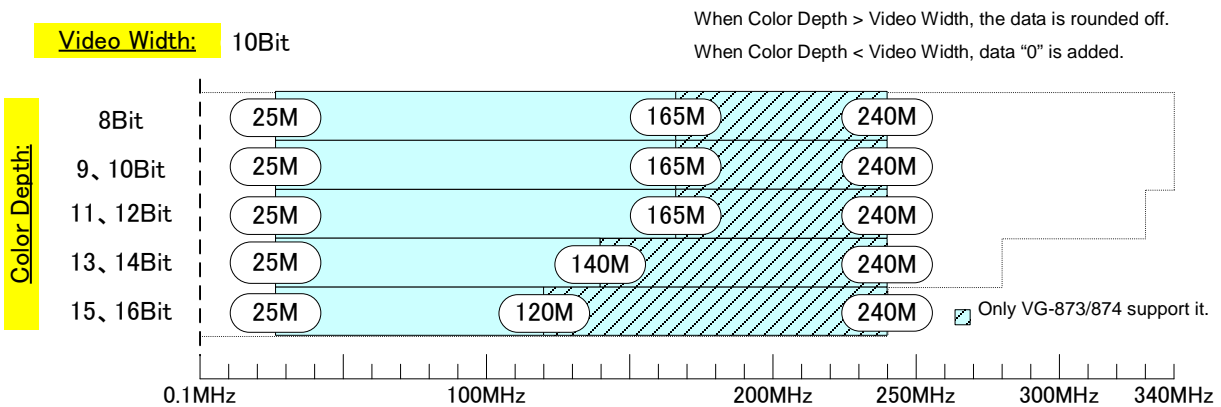
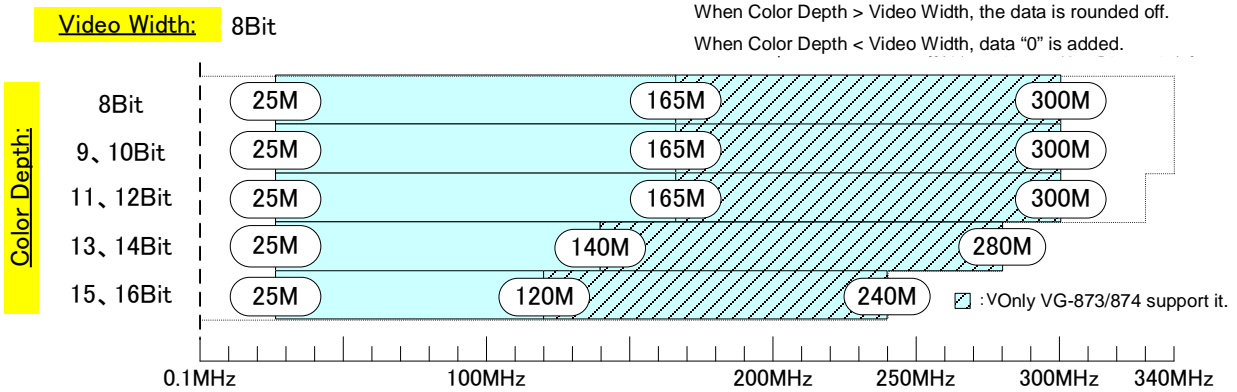

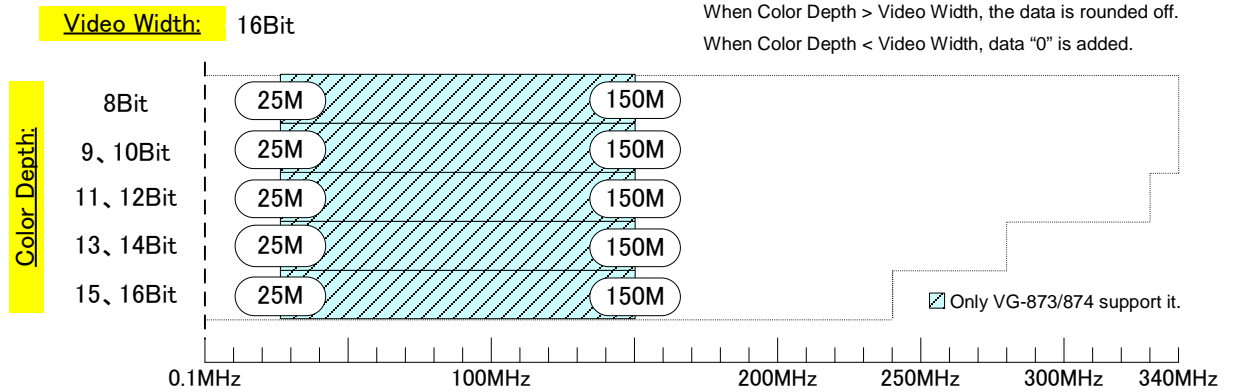

Dot clock limit of HDMI1 and HDMI2

For details on the pattern drawing bit length (Color Depth), refer to “4.1.5 Setting the bit length (gray scale) for pattern drawing.”

For details on the Output video bit length (Video Width), refer to “4.2.2 HDMI setting procedure.”

12.2.2 TV encoder unit (VM-1812)

The dot clock frequency is restricted by the pattern drawing bit length (Color Depth) shown in the figures below. An 8-bit D/A converter is installed in the TV encoder unit, and data skipping occurs when the pattern drawing bit length (Color Depth) is more than 8 bits.

D/A Converter:

8Bit

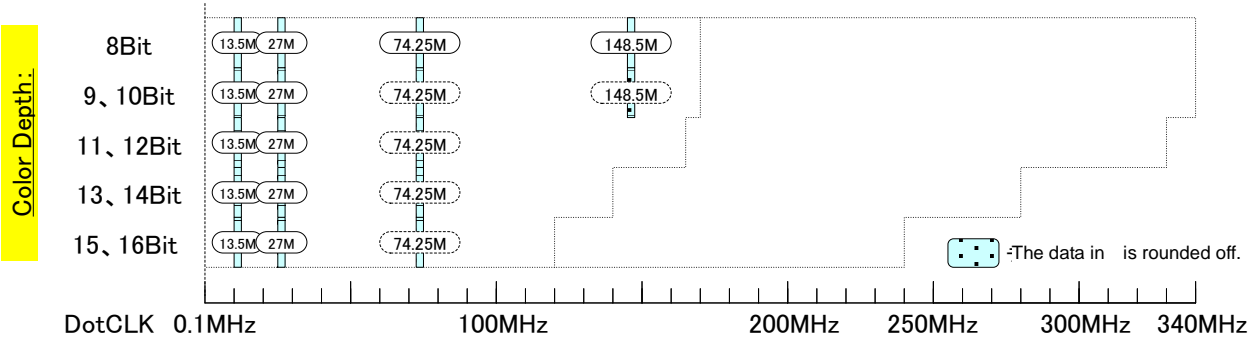

Restrictions on dot clock frequency for D5, YPbPr

D/A Converter:

8Bit

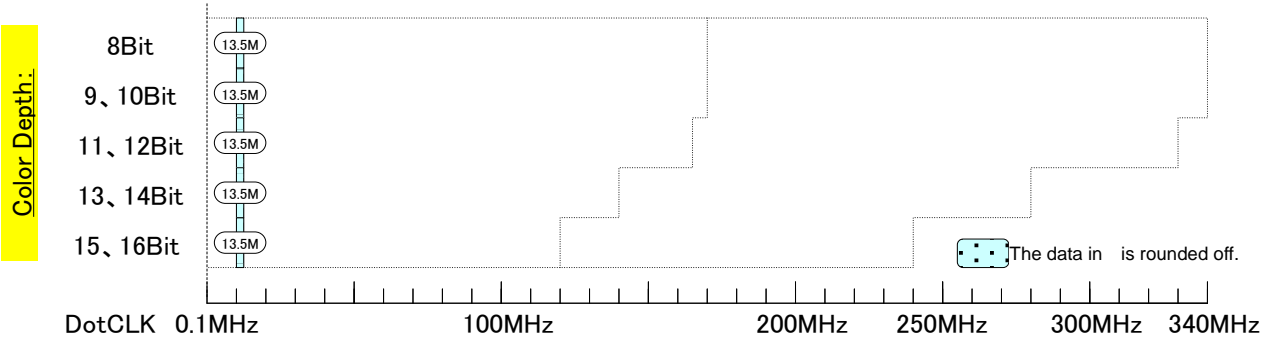

Restrictions on dot clock frequency for COMPOSITE, Y/C (S connector), SCART

D/A Converter:

8Bit

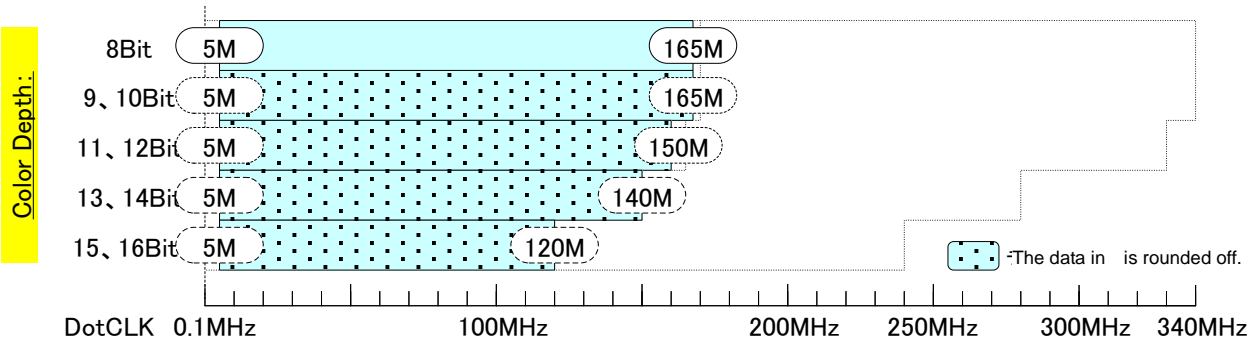

Restrictions on dot clock frequency for VGA

For details on the pattern drawing bit length (Color Depth), refer to "4.1.5 Setting the bit length (gray scale) for pattern drawing."

12.2.3 PC analog unit (VM-1811)

The dot clock frequency is restricted by the pattern drawing bit length (Color Depth) shown in the figures below. 10-bit D/A converter is installed in the PC analog unit, and data skipping occurs when the pattern drawing bit length (Color Depth) is more than 10 bits. A DVI-I (Single Link) unit is also installed, and the data skipping occurs when the pattern drawing bit length (Color Depth) is more than 8 bits.

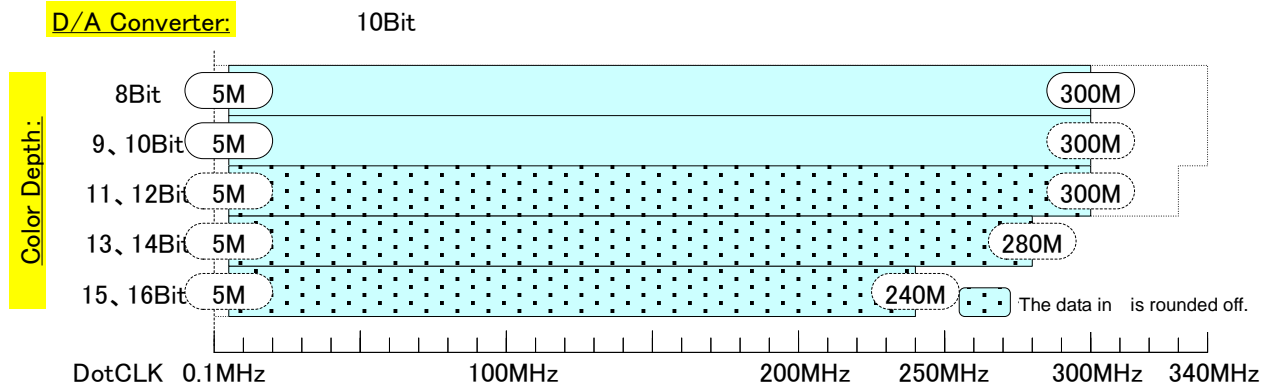

Restrictions on dot clock frequency for RGB, Dsub15, DVI (analog)

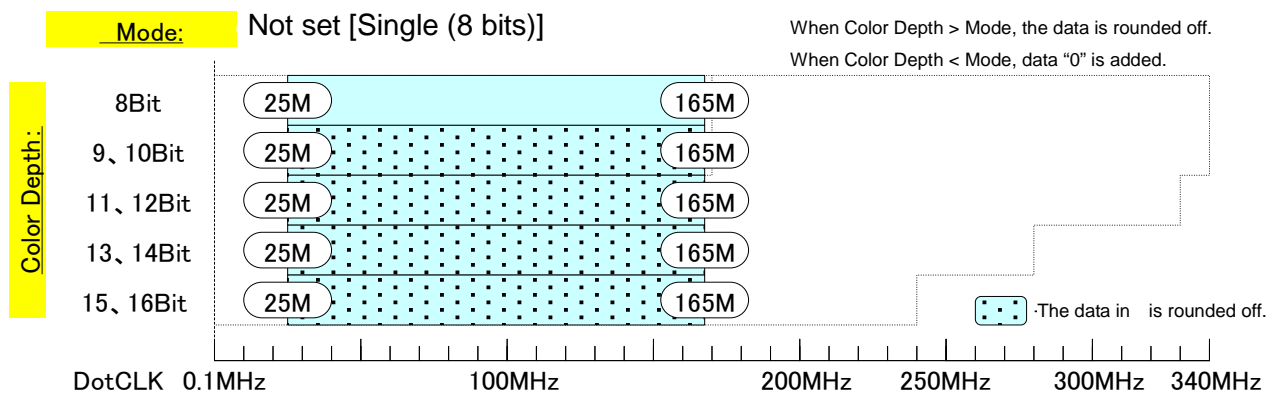

Restrictions on dot clock frequency for DVI (digital)

For details on the pattern drawing bit length (Color Depth), refer to "4.1.5 Setting the bit length (gray scale) for pattern drawing."

12.2.4 DVI unit (VM-1814)

The dot clock frequency is restricted by the pattern drawing bit length (Color Depth) shown in the figures below. Data skipping occurs when the output video bit length (Video Width) at this time is less than the pattern drawing bit length (Color Depth).

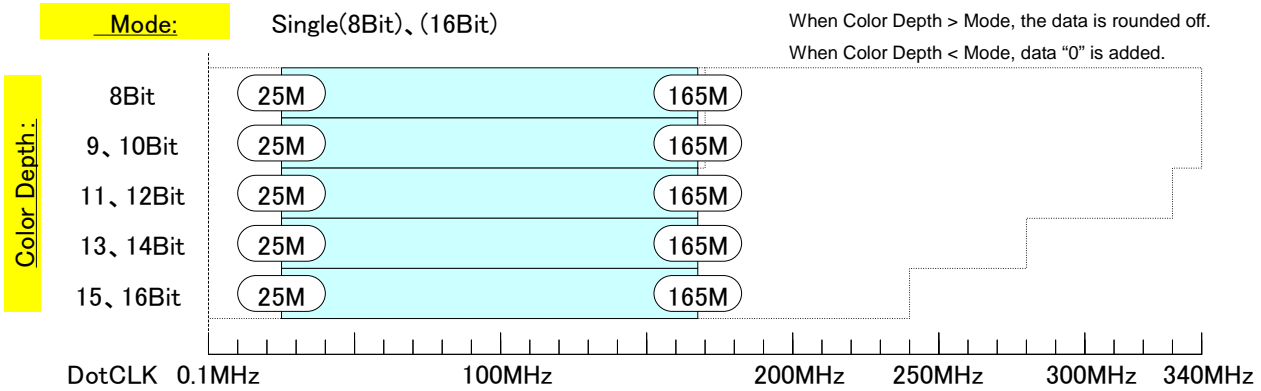

Restrictions on dot clock frequency for DVI (Single Link)

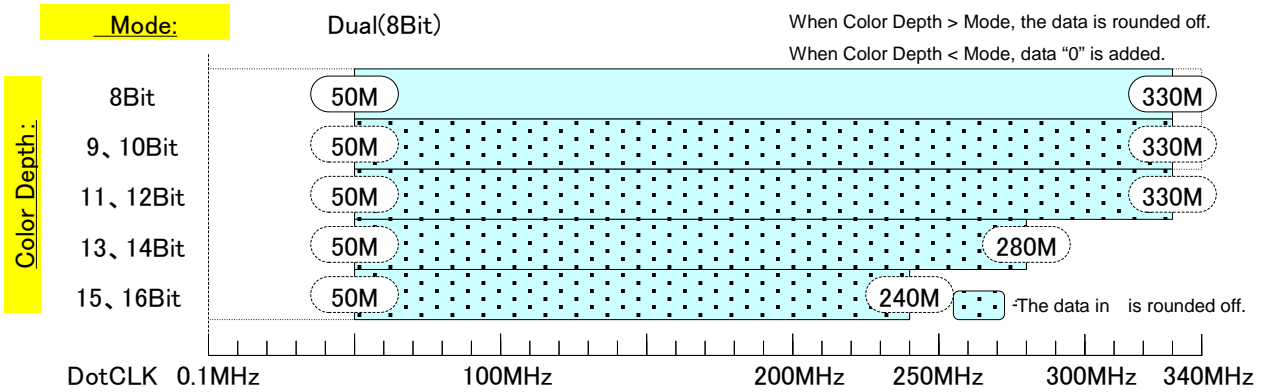

Restrictions on dot clock frequency for DVI (Dual Link)

For details on the pattern drawing bit length (Color Depth), refer to "4.1.5 Setting the bit length (gray scale) for pattern drawing."

For details on the output video bit length (Mode), refer to "4.3.2 DVI unit setting procedure."

12.2.5 LVDS unit (VM-1815)

The dot clock frequency is restricted by the pattern drawing bit length (Color Depth) shown in the figures below. Data skipping occurs when the output video bit length (Video Width) at this time is less than the pattern drawing bit length (Color Depth).

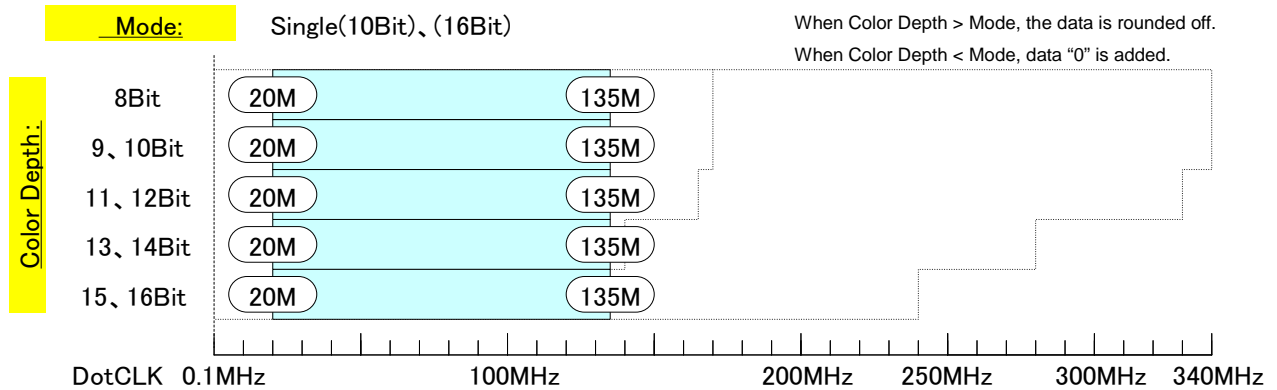

Restrictions on dot clock frequency for LVDS (Single Link)

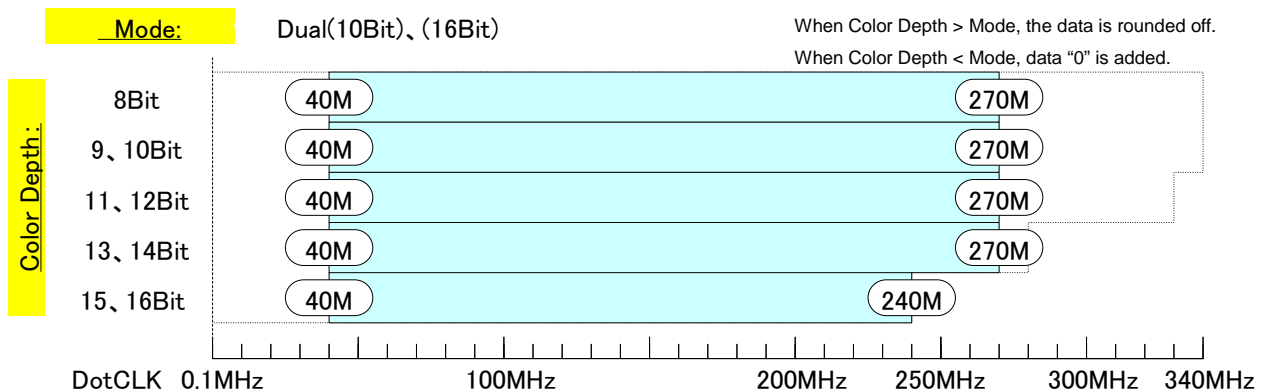

Restrictions on dot clock frequency for LVDS (Dual Link)

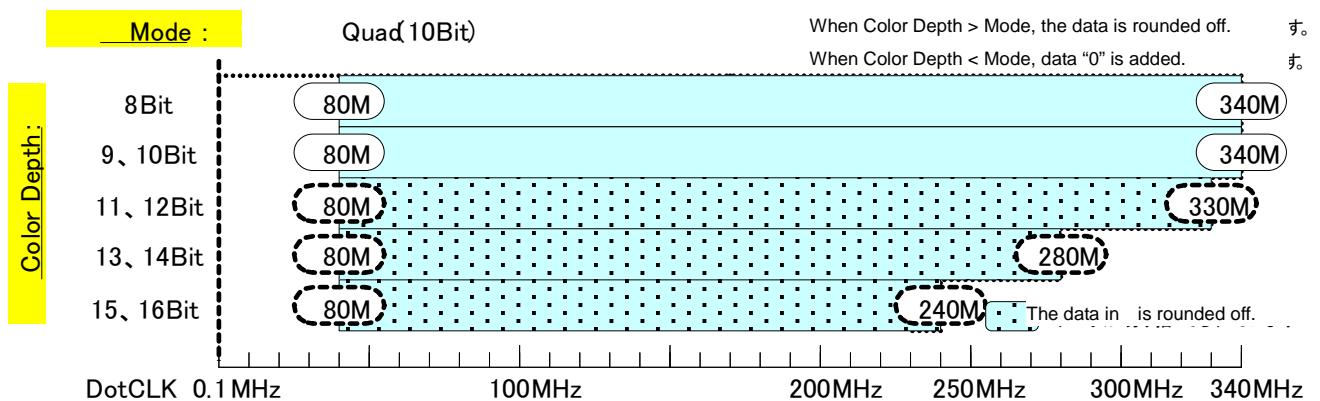

Restrictions on dot clock frequency for LVDS (Quad Link)

For details on the pattern drawing bit length (Color Depth), refer to "4.1.5 Setting the bit length (gray scale) for pattern drawing."

For details on the output video bit length (Mode), refer to "4.5.2 LVDS setting procedure."

12.2.6 Parallel unit (VM-1816)

The dot clock frequency is restricted by the pattern drawing bit length (Color Depth) shown in the figures below. Data skipping occurs when the output video bit length (Video Width) at this time is less than the pattern drawing bit length (Color Depth).

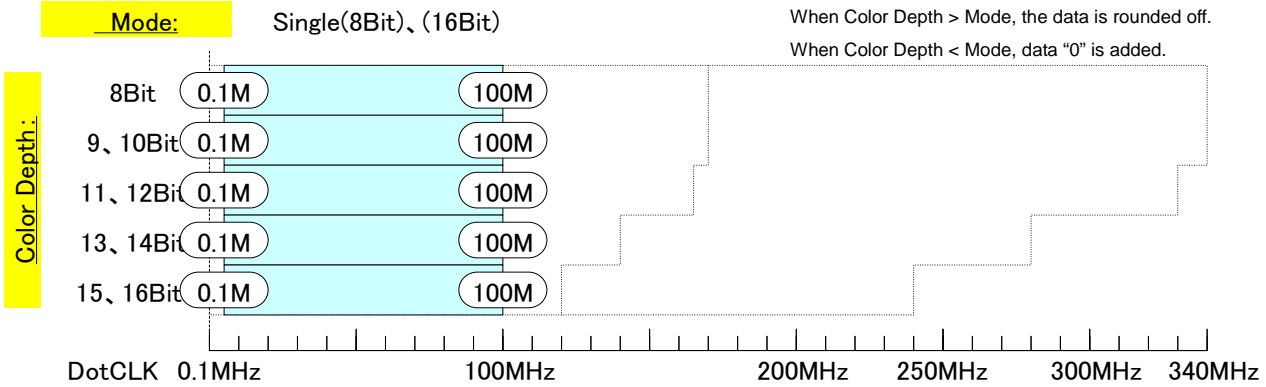

Restriction on parallel (Single Link) dot clock frequency

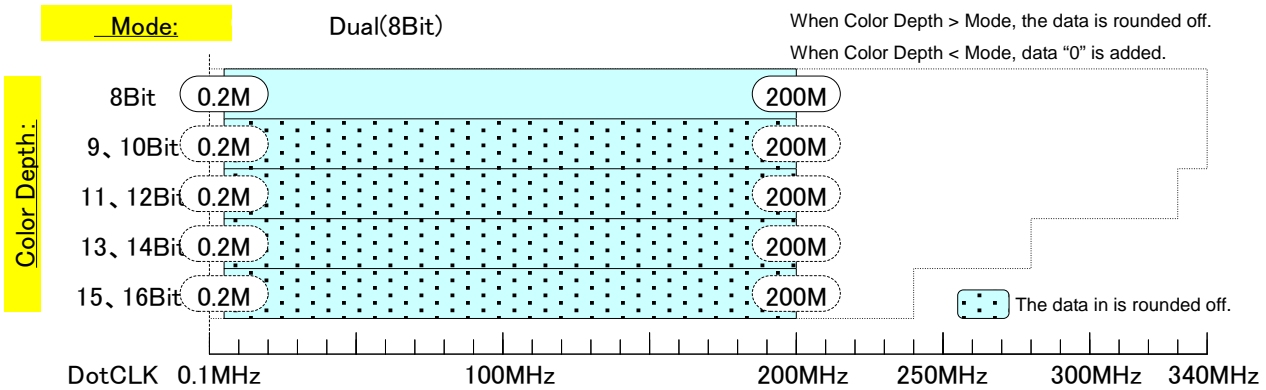

Restriction on parallel (Dual Link) dot clock frequency

For details on the pattern drawing bit length (Color Depth), refer to "4.1.5 Setting the bit length (gray scale) for pattern drawing."

For details on the output video bit length (Mode), refer to "4.6.2 Parallel data setting procedure."

12.2.7 DisplayPort unit (VM-1820, 1820A)

The dot clock frequency is restricted by the pattern drawing bit length (Color Depth) shown in the figure below. Data skipping occurs when the output video bit length (Video Width) at this time is less than the pattern drawing bit length (Color Depth).

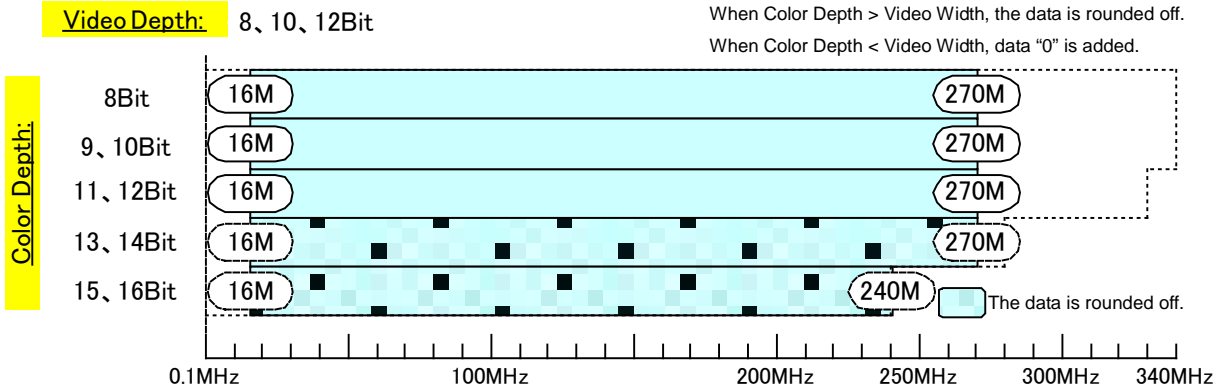

Restrictions on dot clock frequency for DP1, DP2 (Single mode)

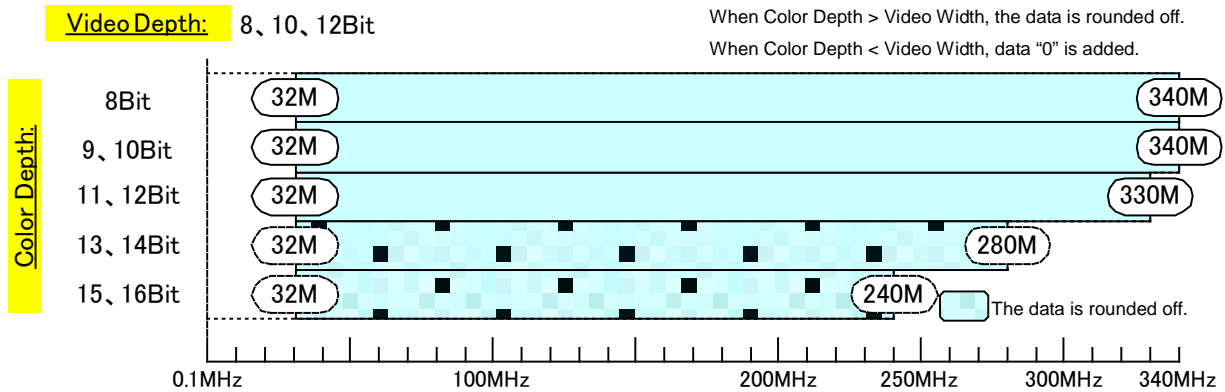

Restrictions on dot clock frequency for DP1, DP2 (Dual/Split mode)

The maximum dot clock also depends on the DisplayPort Link Rate and other settings. For details, refer to "11.1.8 DP unit".

For details on the pattern drawing bit length (Color Depth), refer to "4.1.5 Setting the bit length (gray scale) for pattern drawing".

For details on the output video bit length (Video Width), refer to "4.12.2 DisplayPort setting procedure".

Setting unit of horizontal timing

In Single Mode, H-timing should be set by 2-dot. In Dual/Split Mode, H-timing should be set by 4-dot.

Front porch setting value in interlace timings

Due to the restriction of the DisplayPort Transmitter, Horizontal front porch should be set by 32-dot or higher, or vertical front porch should be set by 1H or higher.

Maximum vertical scanning lines

Due to the restriction of the DisplayPort Transmitter, 2046 is the maximum. (VM-1820 only)

V-total of Interlace timings

Due to the restriction of the DisplayPort Transmitter, only odd-number of V-total (Field-1 + Field 2) is available to output.

The below timing can not be output due to the restriction of DisplayPort transmitter and VG.

The timing that can not be output by VM-1820

Program No.	Timing data name	Program No.	Timing data name
1075	EIA1920x1080i/@50	1528	V Chip US TV-MA-VSL
1324	HD-SDI 720@24p	1531	PAL TELETEXT
1325	HD-SDI 720@23.98p	1541	Mac NTSC-J DVD Type1
1401	NTSC PROG.	1542	Mac NTSC-J DVD Type2
1402	NTSC PROG. W	1543	Mac NTSC-J DVD Type3
1403	NTSC PROG. LB	1544	Mac PAL DVD
1410	NTSC-J 4:3	1551	SCART PAL VBS 4:3
1416	PAL PROG.	1552	SCART PAL Y/C 4:3
1417	PAL PROG. W	1553	SCART PAL RGB 4:3
1418	PAL PROG. LB	1554	SCART PAL VBS 16:9
1422	PAL 4:3	1555	SCART PAL TELETEXT
1438	1280x720@23.98p	1615	VESA1024x768@43
1439	1280x720@24p	1664	VESA1792x1344@120CVT
1451	1920x1035@59.94i	1666	VESA1856x1392@75
1452	1920x1035@60i	1671	VESA1920x1200@85
1453	SMPTE295Mi	1672	VESA1920x1200@120CVT
1454	SMPTE295Mp	1674	VESA1920x1440@75
1455	AUS 1152i	1677	VESA1366x768@60
1501	NTSC-J 4:3	1868	MDA
1502	NTSC-J 16:9	1869	CGA
1503	NTSC-J LB	1870	EGA
1504	PAL 4:3	1904	IBM 8514A
1505	PAL 16:9	1905	IBM 5080
1506	PAL LB	1906	IBM 5550
1507	SECAM 4:3	1908	NAVIGATION
1508	SECAM 16:9	1917	NEC PC9801XL
1509	SECAM LB	1944	Panasonic M550
1510	NTSC-M	1950	NTSC
1511	NTSC-443	1956	MEDICAL-1I
1512	PAL-M	1957	MEDICAL-1N
1513	PAL-60	1958	MEDICAL-2I
1514	PAL-N	1959	MEDICAL-2N
1515	PAL-Nc	1964	SECAM
1521	Closed Caption CC1	1968	NTSC
1522	Closed Caption CC2	1969	PAL
1523	Closed Caption Text1	1974	1035i
1524	Closed Caption Text2	1975	1035i
1525	V Chip MPAA G	1978	483P
1526	V Chip MPAA X	1979	PAL*2
1527	V Chip US TV-Y	1994	NTSC-M

The timing that can not be output by VM-1820A

Program No.	Timing data name	Program No.	Timing data name
1075	EIA1920x1080i/@50	1525	V Chip MPAA G
1410	NTSC-J 4:3	1526	V Chip MPAA X
1422	PAL 4:3	1527	V Chip US TV-Y
1451	1920x1035@59.94i	1528	V Chip US TV-MA-VSL
1452	1920x1035@60i	1531	PAL TELETEXT
1455	AUS 1152i	1541	Mac NTSC-J DVD Type1
1501	NTSC-J 4:3	1542	Mac NTSC-J DVD Type2
1502	NTSC-J 16:9	1543	Mac NTSC-J DVD Type3
1503	NTSC-J LB	1544	Mac PAL DVD
1504	PAL 4:3	1551	SCART PAL VBS 4:3
1505	PAL 16:9	1552	SCART PAL Y/C 4:3
1506	PAL LB	1553	SCART PAL RGB 4:3
1507	SECAM 4:3	1554	SCART PAL VBS 16:9
1508	SECAM 16:9	1555	SCART PAL TELETEXT
1509	SECAM LB	1869	CGA
1510	NTSC-M	1908	NAVIGATION
1511	NTSC-443	1944	Panasonic M550
1512	PAL-M	1950	NTSC
1513	PAL-60	1956	MEDICAL-1I
1514	PAL-N	1964	SECAM
1515	PAL-Nc	1968	NTSC
1521	Closed Caption CC1	1969	PAL
1522	Closed Caption CC2	1974	1035i
1523	Closed Caption Text1	1975	1035i
1524	Closed Caption Text2	1994	NTSC-M

12.2.8 DP/eDP Unit (VM-1826)

The dot clock frequency is restricted by the pattern drawing bit length (Color Depth) shown in the figure below. Data skipping occurs when the output video bit length (Video Width) at this time is less than the pattern drawing bit length (Color Depth).

Video Depth: 8、10、12Bit

When Color Depth > Video Width, the data is rounded off.

When Color Depth < Video Width, data "0" is added.

Number of Data Lane

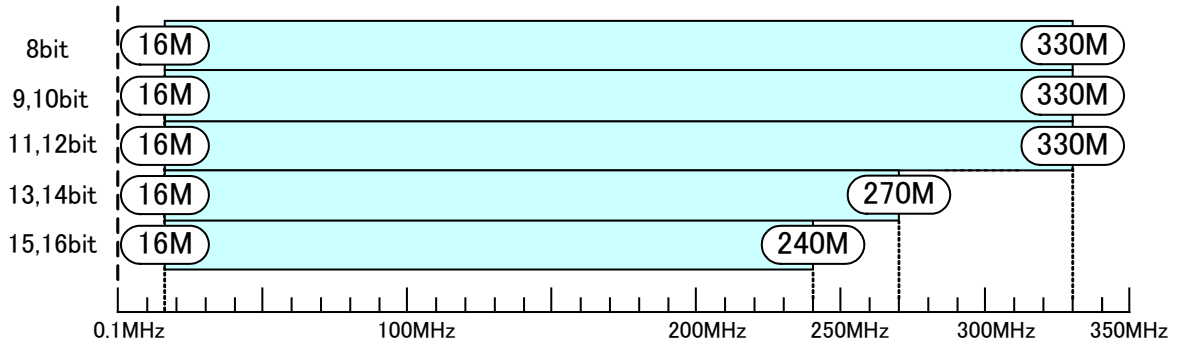

Restrictions on Dot Clock Frequency for DP1, DP2(Single Mode)

Video Depth: 8,10,12bit

When Color Depth > Video Width, the data is rounded off.

When Color Depth < Video Width, data "0" is added.

Color Depth:

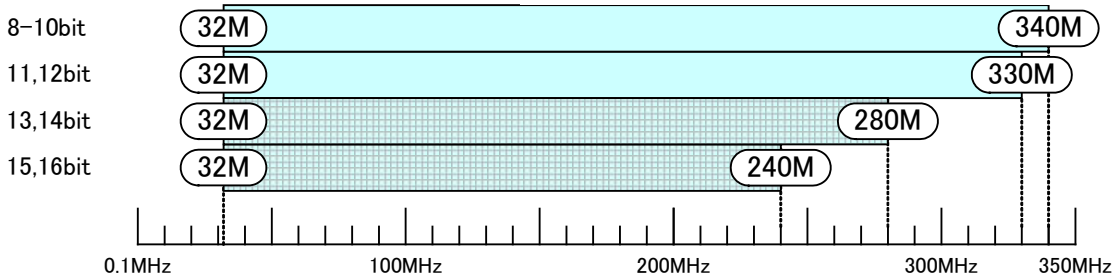

The data in is rounded off.

Restrictions on Dot Clock Frequency for DP1, DP2(Dual Mode)

Video Depth: 8,10,12bit

When Color Depth > Video Width, the data is rounded off.

When Color Depth < Video Width, data "0" is added.

Color Depth:

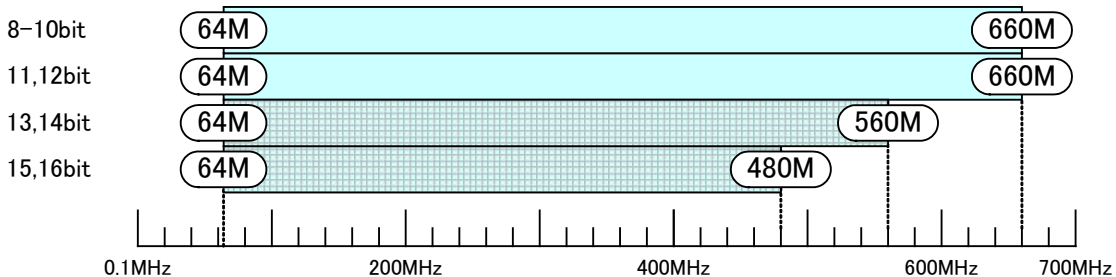

The data in is rounded off.

Restrictions on Dot Clock Frequency for DP1, DP2(Split Mode)

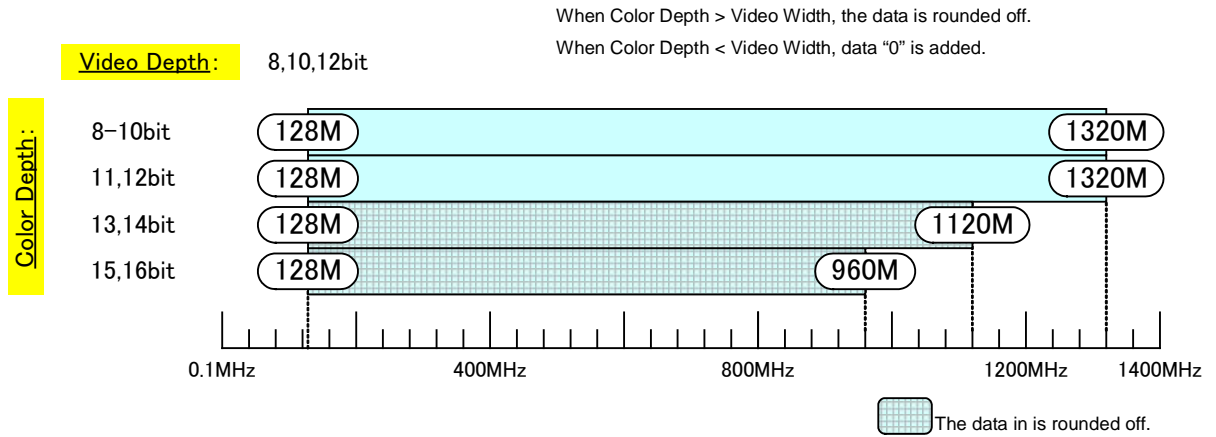

Restrictions on Dot Clock Frequency for DP1, DP2(Split 2 Mode)

The maximum dot clock also depends on the DisplayPort Link Rate and other settings. For details, refer to "11.1.8 DP unit". For details on the pattern drawing bit length (Color Depth), refer to "4.1.5 Setting the bit length (gray scale) for pattern drawing".

For details on the output video bit length (Video Width), refer to "4.12.2 DisplayPort setting procedure".

The below timings can not be output because of restrictions of DisplayPort Transmitter and VG unit. (including the above descriptions.)

The timing that can not be output by VM-1826

Program No.	Timing data name	Program No.	Timing data name
1075	EIA1920x1080i/@50	1525	V Chip MPAA G
1410	NTSC-J 4:3	1526	V Chip MPAA X
1422	PAL 4:3	1527	V Chip US TV-Y
1451	1920x1035@59.94i	1528	V Chip US TV-MA-VSL
1452	1920x1035@60i	1531	PAL TELETEXT
1455	AUS 1152i	1541	Mac NTSC-J DVD Type1
1501	NTSC-J 4:3	1542	Mac NTSC-J DVD Type2
1502	NTSC-J 16:9	1543	Mac NTSC-J DVD Type3
1503	NTSC-J LB	1544	Mac PAL DVD
1504	PAL 4:3	1551	SCART PAL VBS 4:3
1505	PAL 16:9	1552	SCART PAL Y/C 4:3
1506	PAL LB	1553	SCART PAL RGB 4:3
1507	SECAM 4:3	1554	SCART PAL VBS 16:9
1508	SECAM 16:9	1555	SCART PAL TELETEXT
1509	SECAM LB	1869	CGA
1510	NTSC-M	1908	NAVIGATION
1511	NTSC-443	1944	Panasonic M550
1512	PAL-M	1950	NTSC
1513	PAL-60	1956	MEDICAL-1I
1514	PAL-N	1964	SECAM
1515	PAL-Nc	1968	NTSC
1521	Closed Caption CC1	1969	PAL
1522	Closed Caption CC2	1974	1035i
1523	Closed Caption Text1	1975	1035i
1524	Closed Caption Text2	1994	NTSC-M

12.2.9 4K2K (iTMDs) unit (VM-1824, 1824-A)

The dot clock frequency is restricted by the pattern drawing bit length (Color Depth) shown in the figure below. Data skipping occurs when the output video bit length (Video Width) at this time is less than the pattern drawing bit length (Color Depth).

Video Depth: Single(8Bit), (16Bit)

When Color Depth > Video Width, the data is rounded off.
When Color Depth < Video Width, data "0" is added.

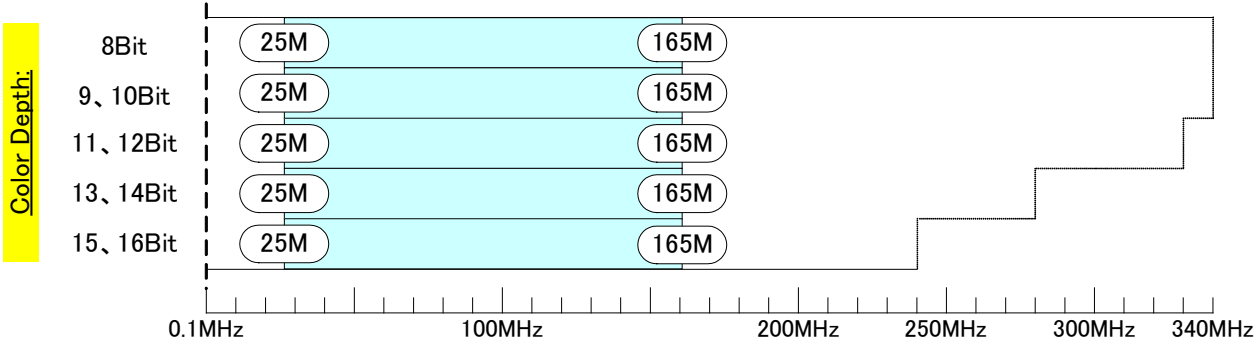

Restrictions on dot clock frequency for 4K2K(iTMDs) (DVI MODE/Single Link)

Video Depth: Dual(8Bit), (16Bit)

When Color Depth > Video Width, the data is rounded off.
When Color Depth < Video Width, data "0" is added.

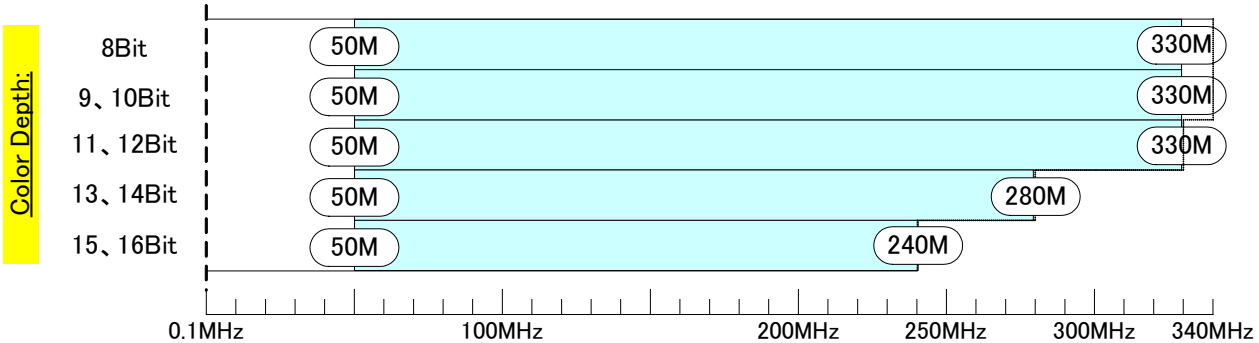

Restrictions on dot clock frequency for 4K2K(iTMDs) (DVI MODE/Dual Link)

Video Depth: Quad(8Bit)

When Color Depth > Video Width, the data is rounded off.
When Color Depth < Video Width, data "0" is added.

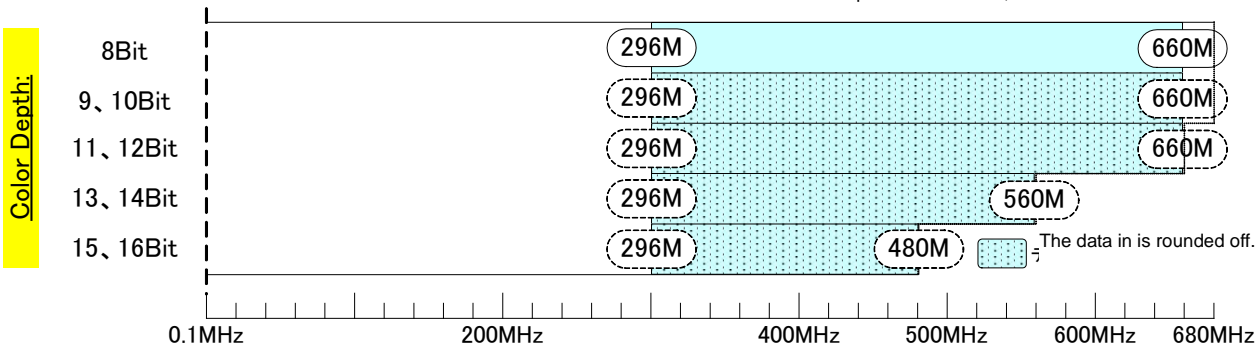

Restrictions on dot clock frequency for 4K2K(iTMDs) (DVI MODE/Quad Link)

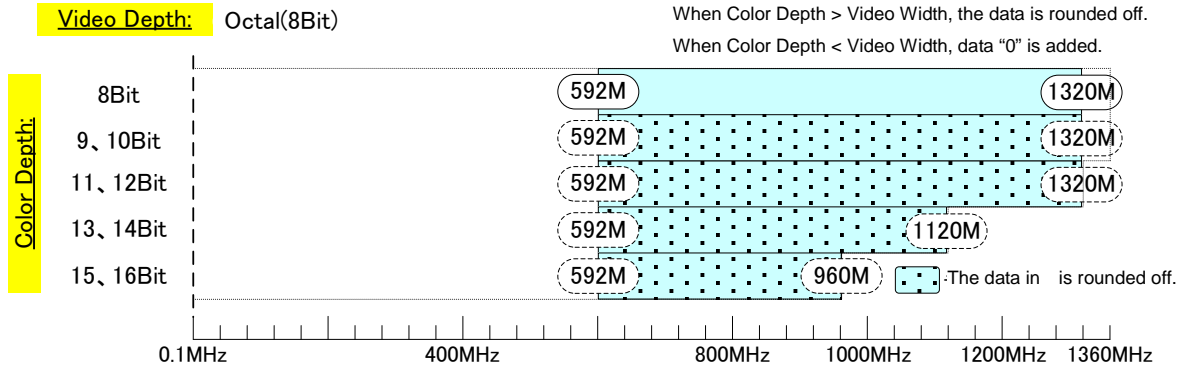

Restrictions on dot clock frequency for4K2K(iTMS)(DVI MODE/Octal Link)

Video Depth: Single(iTMDS)

When Color Depth > Video Width, the data is rounded off.
When Color Depth < Video Width, data "0" is added.

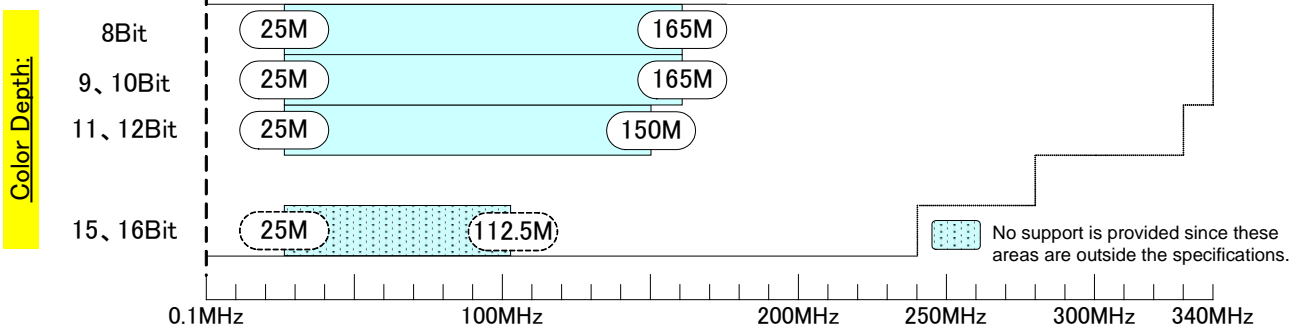

Restrictions on dot clock frequency for iTMDS(iTMDS MODE/Single Link)

Video Depth: Dual(iTMDS)

When Color Depth > Video Width, the data is rounded off.
When Color Depth < Video Width, data "0" is added.

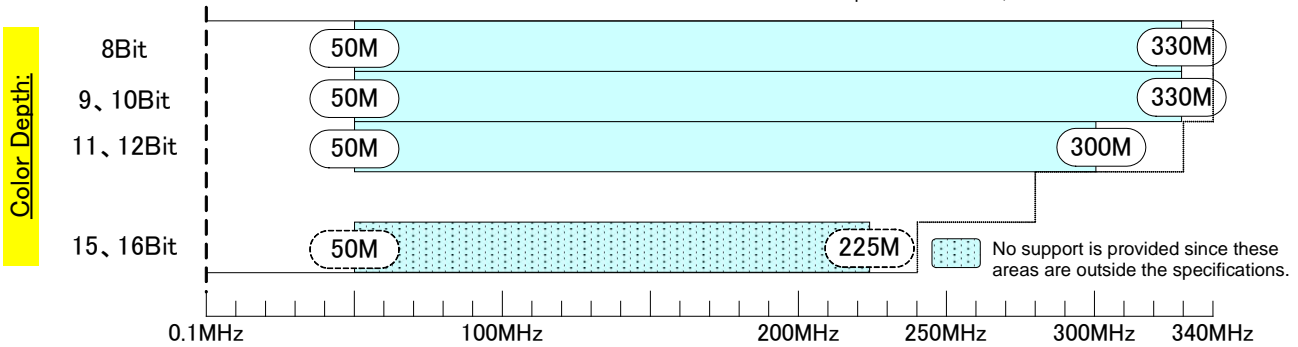

Restrictions on dot clock frequency for iTMDS(iTMDS MODE/Dual Link)

Video Depth: Quad(iTMDS)

When Color Depth > Video Width, the data is rounded off.
When Color Depth < Video Width, data "0" is added.

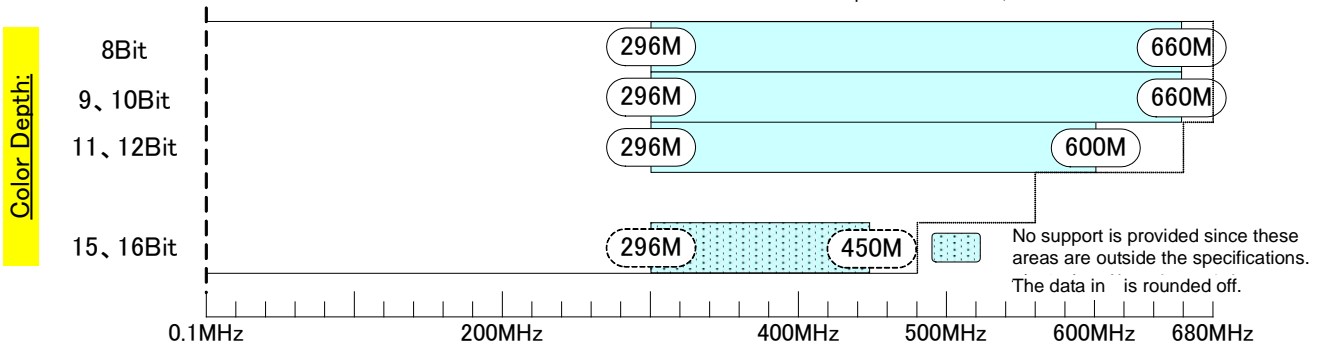

Restrictions on dot clock frequency for iTMDS(iTMDS MODE/Quad Link)

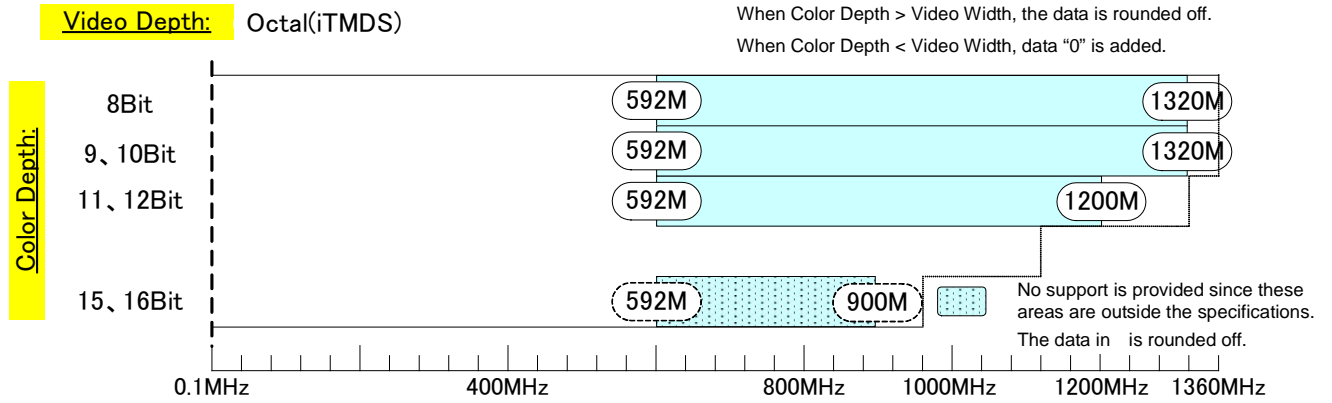

Restrictions on dot clock frequency for iTMDS(iTMDS MODE/Octal Link)

For details on the pattern drawing bit length (Color Depth), refer to "4.1.5 Setting the bit length (gray scale) for pattern drawing."

For details on the output image bit length (Mode), refer to "4.4.2 iTMDS (4Kx2K) unit setting procedure."

12.2.10 V-by-One HS unit

The dot clock frequency is restricted by the pattern drawing bit length (Color Depth) shown in the figure below. Data skipping occurs when the output video bit length (Video Width) at this time is less than the pattern drawing bit length (Color Depth).

Video Depth: 8,10bit

When Color Depth > Video Width, the data is rounded off.
When Color Depth < Video Width, data "0" is added.

Color Depth:

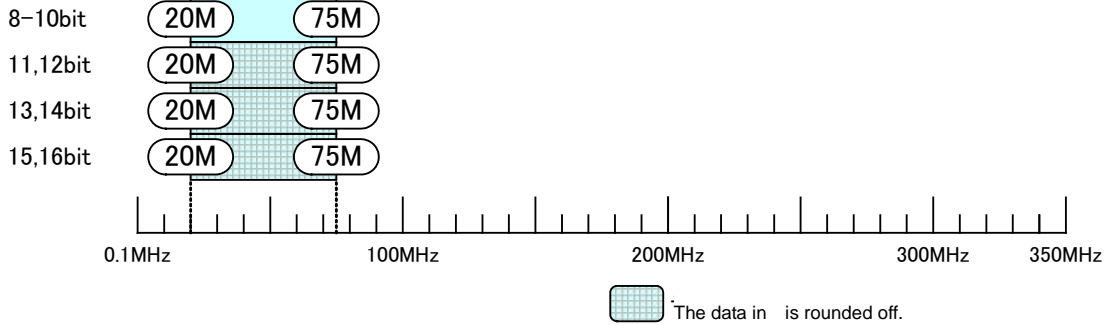

Restrictions on dot clock frequency for V-by-One HS1/2(1Lane Mode)

Video Depth: 8,10bit

When Color Depth > Video Width, the data is rounded off.
When Color Depth < Video Width, data "0" is added.

Color Depth:

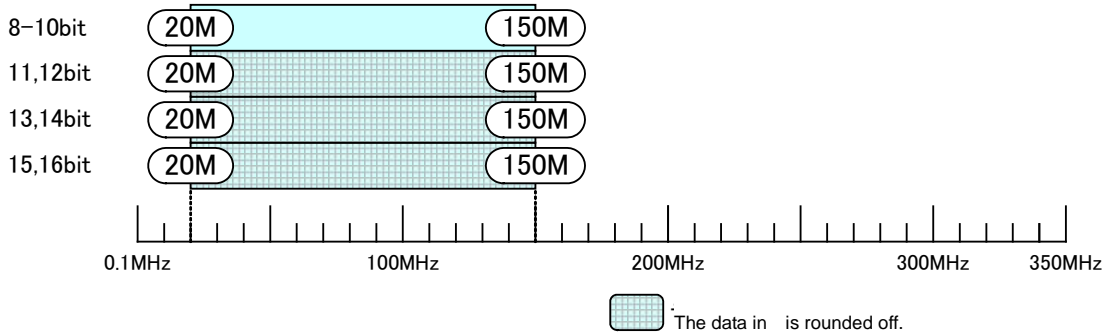

Restrictions on dot clock frequency for V-by-One HS1/2(2Lane Mode)

Video Depth: 8,10bit

When Color Depth > Video Width, the data is rounded off.
When Color Depth < Video Width, data "0" is added.

Color Depth:

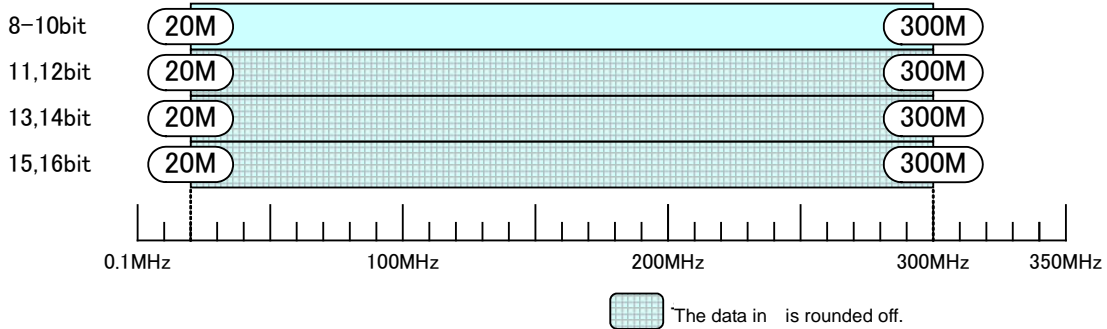

Restrictions on dot clock frequency for V-by-One HS1/2(4Lane Mode)

Video Depth: 8,10bit

When Color Depth > Video Width, the data is rounded off.
When Color Depth < Video Width, data "0" is added.

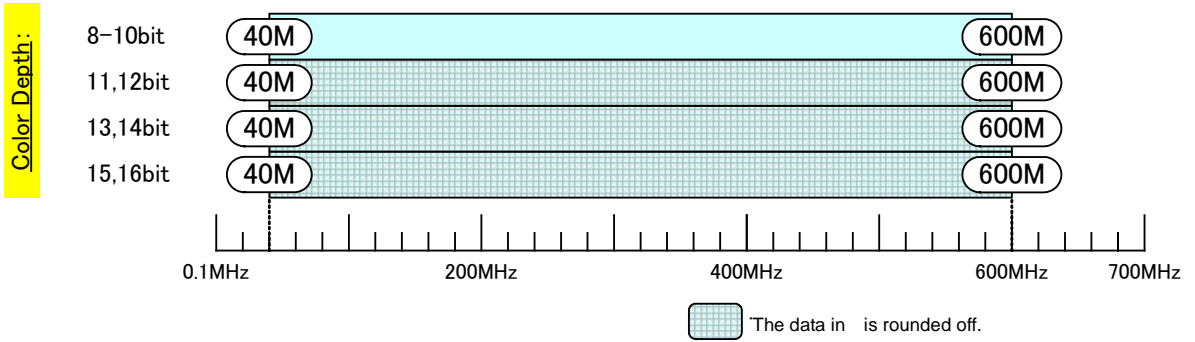

Restrictions on dot clock frequency for V-by-One HS1/2(8Lane Mode)

Video Depth: 8,10bit

When Color Depth > Video Width, the data is rounded off.
When Color Depth < Video Width, data "0" is added.

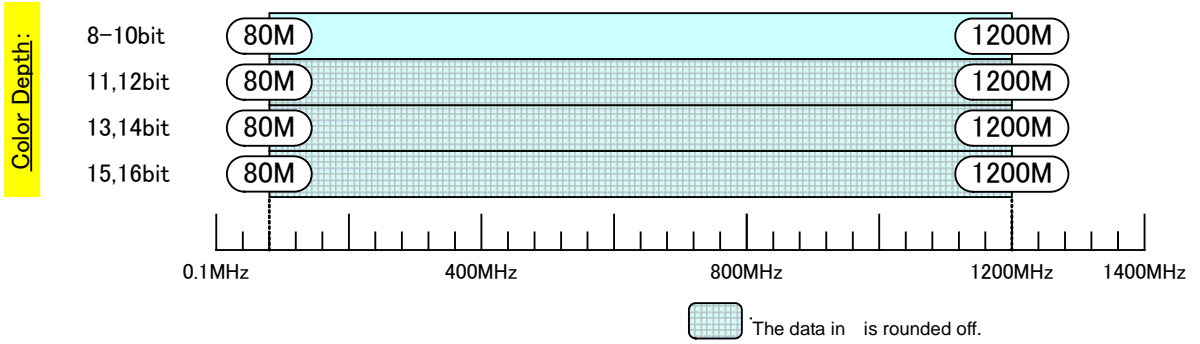

Restrictions on dot clock frequency for V-by-One HS1/2(16Lane Mode)

12.3 Concerning the maximum current consumption of the DDC (DP_PWR) power supply

DDC power (DP_PWR in case of DisplayPort output) is supplied to the outputs of the VG-870B/871B.

The maximum currents supplied by the DDC power supply are as listed below.

- HDMI output: 0.050 A for each channels
- DVI output: 0.5 A total for 2 channels
- LVDS 4-channel output: 0.5 A total for channels 1 to 4, and max. 0.5 A per channel
- Parallel output (2 channels): 0.5 A total for channels 1 and 2, and max. 0.5 A per channel
- TV encoder output: 0.5 A total for all channels
- PC analog output: 0.5 A total for all channels
- DisplayPort output: 0.5 A total for all channels

1) The DDC supply voltage is output as shown in the figure below.

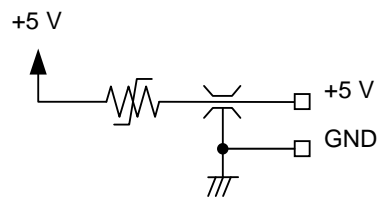

DDC power supply output circuit

2) The supply voltage differs depending on the output connector.

- HDMI output: Fixed at 5 V.
- DVI output: Fixed at 5 V.
- LVDS output: Can be switched between 5 V and 3.3 V using a rear panel switch.
- Parallel output: Can be switched between 5 V, 3.3 V, 2.5 V and 1.8 V using a rear panel switch.
- TV encoder output: Fixed at 5 V.
- PC analog output: Fixed at 5 V.
- DisplayPort output: Fixed at 3.3 V.

CAUTION

- The DDC power supply incorporates an overcurrent protection device, but do not use a current which exceeds the rating.
- Do NOT supply power to the DDC power supply from the device connected to the VG. If such the voltage of such a power supply is connected, both the VG and the connected device may fail.

13

LIST OF ERROR MESSAGES

13.1 Media-related error

Code (HEX)	Error message	Description
217	Flash ROM(User) Full	There is not enough free space in the internal memory.
228	No CF-Card	The CF card has not been inserted.
229	CF-Card Unformatted	The CF card has not been formatted.
22A	CF-Card Full	There is not enough free space on the CF card.
22C	OPT Data File Error	Error in the optional pattern data.
22F	Image Data File Error	Error in the image data.
233	Audio Flash Data Already Exist	The audio data has already been registered.
235	Audio Flash File Error	Error in the audio data.
236	Audio Flash Data Full	The maximum amount of audio data which can be registered has been exceeded.

13.2 General error

Code (HEX)	Error message	Description
302	'H-Timing DotClock' Over Limit	Dot clock in the horizontal timing data is outside the setting range.
303	'H-Timing Frontp' Over Limit	Frontp in the horizontal timing data is outside the setting range.
305	'H-Timing HD' Over Limit	HDstart+HDwidth in the horizontal timing data is outside the setting range.
307	'H-Timing Period' Over Limit	Period in the horizontal timing data is outside the setting range.
308	'H-Timing Disp' Over Limit	Disp in the horizontal timing data is outside the setting range.
309	'H-Timing Sync' Over Limit	Sync in the horizontal timing data is outside the setting range.
30A	'H-Timing Backp' Over Limit	Backp in the horizontal timing data is outside the setting range.
30B	'H-Timing Blanking' Over Limit	Blanking in the horizontal timing data is outside the setting range.
30C	H-Frequency Over Limit	The horizontal sync frequency in the horizontal timing data is outside the setting range.
30D	'H-Timing' Data Error	Error other than those described above in the horizontal timing data.
310	'Output' Data Error"	Error in the output condition data.
311	'Character' Data Error"	Error in the character pattern data.
312	'Cross Hatch' Data Error"	Error in the crosshatch pattern data.
313	'Dot' Data Error"	Error in the dot pattern data.
314	'Circle' Data Error"	Error in the circle pattern data.

Code (HEX)	Error message	Description
315	'Burst' Data Error"	Error in the burst pattern data.
316	'Window' Data Error"	Error in the window pattern data.
317	'Color Bar' Data Error"	Error in the color bar pattern data.
318	TERMINAL) Parameter Error	Error in a parameter in the terminal mode.
319	TERMINAL) Data Error	Error in the data in the terminal mode.
31B	'Video/Setup/Sync Level' Error	The video level (Video), setup level (Setup) and sync signal level (Sync) are outside the setting range. (Setting range: [Video ≥ Setup] and [Video ≥ Sync] and [Video ≥ (Setup + Sync)])
31E	TERMINAL) Communication Timeout	Time-out has occurred in the data during communication in the terminal mode.
31F	TERMINAL) Undefined Command	An undefined command was received in the terminal mode.
321	'Program No.' Error"	Error in the program number.
322	'Group No.' Error"	Error in the group number.
323	'Character Code' Error"	Error in a user character code.
32B	'OPT No.' Error"	Error in the optional pattern number.
32D	OPT Data File Not Found"	The optional pattern has not been registered.
32E	'Image No.' Error"	Error in the image pattern number.
330	Image Data File Not Found"	The image pattern has not been registered.
333	CURSOR Not Selected	The cursor pattern has not been selected (when SP-8870 Cursor Tool is used).
334	EDID Read Port Not Found	The EDID read port is not found. (The unit has not been installed.)
338	'Gray Scale' Data Error	Error in the gray scale pattern data.
339	'OPT/Image' Data Error"	Error in the optional pattern or image pattern data.
33B	'Cursor' Data Error	Error in the cursor pattern data.
33C	'Program Name' Data Error	Error in the program name data.
33D	'□×[ABC] Color' Data Error	Error in the □ × [ABC] color data.
33E	'Action' Data Error"	Error in the action data.
340	'V-Timing Total' Over Limit	Total in the vertical timing data is outside the setting range.
341	'V-Timing Disp' Over Limit"	Disp in the vertical timing data is outside the setting range.
342	'V-Timing Sync' Over Limit	Sync in the vertical timing data is outside the setting range.
343	'V-Timing Backp' Over Limit	Backp in the vertical timing data is outside the setting range.
344	'V-Timing Frontp' Over Limit	Frontp in the vertical timing data is outside the setting range.
345	'V-Timing Blanking' Over Limit	Blanking in the vertical timing data is outside the setting range.
346	V-Frequency Over Limit	The vertical sync frequency in the vertical timing data is outside the setting range.
347	'V-Timing VD' Over Limit	VDstart+VDwidth in the vertical timing data is outside the setting range.

Code (HEX)	Error message	Description
348	'V-Timing EQP-Fp' Over Limit	EQP-FP in the vertical timing data is outside the setting range.
349	'V-Timing EQP-Bp' Over Limit	EQP-BP in the vertical timing data is outside the setting range.
34A	'V-Timing' Data Error	Error other than those described above in the vertical timing data.
34E	DDC2 Line Error	ACK was not received in DDC2.
350	Macrovision Not Supported	An IC supporting Macrovision has not been installed in the unit.
352	EDID Header Error	Error in the EDID header.
353	EDID Check Sum Error	EDID checksum error.
354	EDID Header & Check Sum Error	Errors in both the EDID header and checksum.
355	User YPbPr Coefficient Error	Error in the color difference coefficients.
358	Audio Data No. Error	Error in the audio data number.
35A	Audio Data File Not Found	The audio data has not been registered.
35D	Lip Sync Invalid EDID Latency	Error in the EDID at the connection destination (when Mode:EDID has been selected with LipSync).
35F	Lip Sync 'EDID Port' Error	The HDMI unit is not installed (when Mode:EDID has been selected with LipSync).
360	Image License Error	The image data license has not been supplied.
361	Data File Not Found	The data (other than the optional pattern and image data) cannot be found.
362	Copy Condition Error	<ul style="list-style-type: none"> • The copy source data and copy destination data are identical. • The number of copy source data and number of copy destination data are different.
363	Image RAM Full	There is not enough free space in the image memory. Set the high-speed drawing mode in 9.1.16 to OFF or reduce the number of data specified.
373	DP I2C NACK Error	The response to AUX CH Read/Write is "I2C NACK".
374	DP I2C Defer Error	The response to AUX CH Read/Write is "I2C DEFER".
375	eDP Power Under Volt Error	When pressing SIG ON key, the voltage value of external power input is less than 1V.
376	eDP Changed Power Setting	When pressing SIG ON key, power control parameter tries to change to the different program.
377	eDP Power Supply Control OFF	When pressing SIG ON key, power control is OFF.

13.3 HDCP-related error

Code (HEX)	Error message	Description
403	HDCP) Transmitter KSV Error	KSV of the transmitter does not contain twenty '0's and '1's.
404	HDCP) Receiver KSV Error	KSV of the receiver does not contain twenty '0's and '1's.
405	HDCP) Link Check Error	During initial validation, the values did not match ($R0 \neq R0'$).
406	HDCP) Encryption Error	Encryption was not completed.
407	HDCP) Hot Plug Error	The device to be connected is not connected.
408	HDCP) Ri Ready Error	The ready bit of the receiver was not set high.
412	HDCP) I2C Line Error	The I2C line is not working properly.
414	HDCP) Receiver Not HDMIMode	The connected device (receiver) was not set to the HDMI mode when the HDCP version was identified as 1.1 as a result of HDCP version:1.1 or HDCP version: EDID check.
415	HDCP) Ri NG	The values of Ri and Ri' do not match.
416	HDCP) FIFO Ready Time-out	FIFO Ready fails to occur within restricted time limit.
417	HDCP) DEPTH Error	The depth number has exceeded '7'.
418	HDCP) DEVICE_COUNT Error	The count number has exceeded '127'.
419	HDCP) List Error ($V' \neq V$)	The values of V and V' do not match.

13.4 User-generated optional pattern-related error

Code (HEX)	Error message	Description
501	OPT Program Not Found	The user-generated optional pattern is not found.
502	Variables Stack Error	Variable stack error.
503	Register Stack Error	Register stack error.
504	Call Stack Error	Function stack error.
505	Illegal Instruction Code	Illegal instruction code.
506	Divide by Zero	An attempt was made to divide a number by zero.
539	OPT-USER License Error	The user-generated optional pattern license has not been supplied.

NOTICE

- An incorrectly collated manual or a manual with missing pages will be replaced.
- All copyrights pertaining to this product are the property of ASTRODESIGN.
- This manual may not be copied in whole or in part without written permission.
- The contents of this manual are subject to change without prior notice due to improvements.
- The manufacturer will not be liable for any effects caused by incorrect operation.
- All inquiries concerning this product should be addressed to your dealer or to the manufacturer at the contact numbers given below.
- The products and product names mentioned in this manual are the trademarks and registered trademarks of the companies concerned.

T0170I

ASTRODESIGN, Inc.

URL <http://www.astrodesign.co.jp>

● For more information, please contact us :

TOKYO HQ

TEL +81-(0)3-5734-6320 FAX +81-(0)3-5734-6104

1-5-2 Minami-yukigaya, Ota-ku, Tokyo, Japan 145-0066

USA HQ

TEL +1-408-235-2322 FAX +1-408-235-2324

2700 Augustine Drive Suite 101 Santa Clara CA 95054 USA